

User Manual

Variable Gain Amplifier • Model 1805



Audio  Authority®

Introduction

The Audio Authority® Model 1805 is a compact amplifier designed to provide amplification for speakers in retail demonstrations. Volume may be controlled via RS-232 or RS-485 using custom control devices such as a touch screen or capacitive touch panel. Gain may be set per channel. For best results use a commercial grade media player such as the Model 1803 or MH2-HD MediaHub.



COMPATIBLE WITH
AUDIO AUTHORITY
MEDIAHUBS

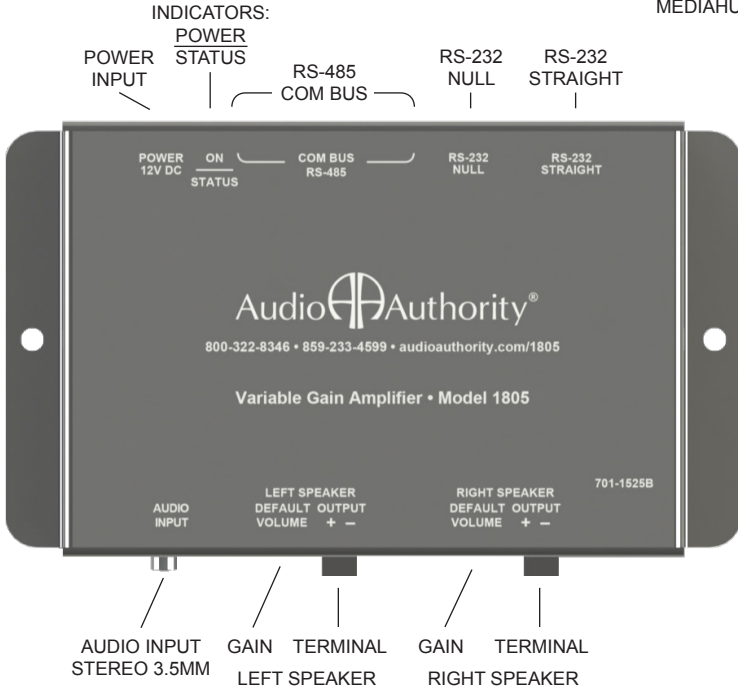

Features

- Up to 10.5 watts per channel power output
- Volume may be controlled by RS-232 or RS-485
- Gain adjustment per channel
- Small footprint for easy placement in displays and fixtures

Audio Input

Connect a stereo analog audio source to the 3.5mm stereo Audio Input jack. If the source has volume control, raise the volume controls to the point of distortion, then adjust it down to the maximum level.

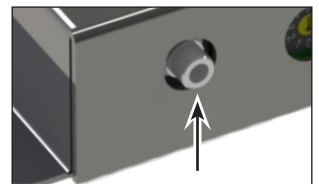

3.5MM AUDIO JACK

RS-232 Ports

The RS-232 ports receive and pass-thru communications to other serial devices at 9600 Baud rate. A variety of RJ-45 serial cable adapters are available from Audio Authority. Serial commands shown in table below.

| Volume Up | Volume Down | Discreet Volume Commands |
|-----------|-------------|---------------------------|
| [VOL+] | [VOL-] | [VOL=0] Min [VOL=128] Max |

RS-485 Bus

The RS-485 communication pathway is for use with custom applications such as TouchSelect control panels and BrightSign® media players.

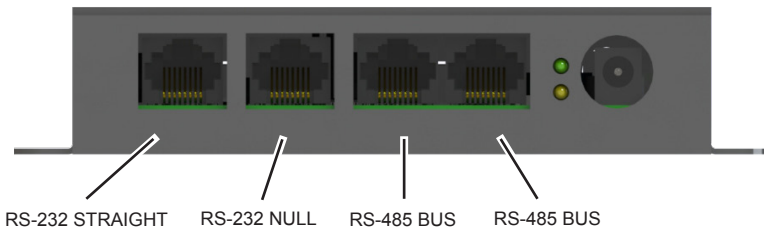

Power

Connect the 12V power supply (included) to the jack marked Power Input.

Indicators

The green Power LED provides visual indication of the amplifier's on/off state. The yellow Status LED indicates when the input is over-driven or when the speaker outputs have a short.

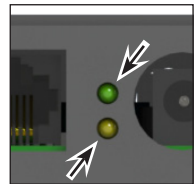

How to Set the Model 1805 Amplifier Gain Controls

- Raise the source volume controls (if present) to maximum.
- Turn the 1805 gain dials (*left and right channels*) to 1 and start the audio source playing.
- Select a speaker position, and raise the 1805 gain dials to the point of distortion, then reduce to the desired maximum level. Check all of the connected speakers for distortion, readjust 1805 gain levels if necessary.

GREEN POWER AND
YELLOW STATUS



Power Specifications

Measurements with an 8 ohm load, both channels driven:

| 12V | THD | Watts per channel |
|----------------------------|-----|-------------------|
| Power Supply PN:571-043 | 1% | 8.5 |
| | 10% | 10.5 |

Frequency response at 8.5W per channel: +/- 1.452 dB 20Hz-20kHz

Installation

- Attach the amplifier to a flat surface with the screws provided.
- Allow adequate ventilation for amplifier.
- Connect speaker terminals securely.
- Connect 3.5mm stereo cable from source.
- Connect power supply to AC power, then to the power port.
- Adjust gain (*see page 3*).
- Call Audio Authority with questions that are not addressed in this manual.

Example System:

The 1805 sends amplified audio to the Model 1819 switch modules that route audio to the speakers. The 1803 media player's MicroSD card contains the uncompressed audio content and provides the low-level input signal for the 1805 amplifier. The TS09 controls the demonstration system via RS-485.

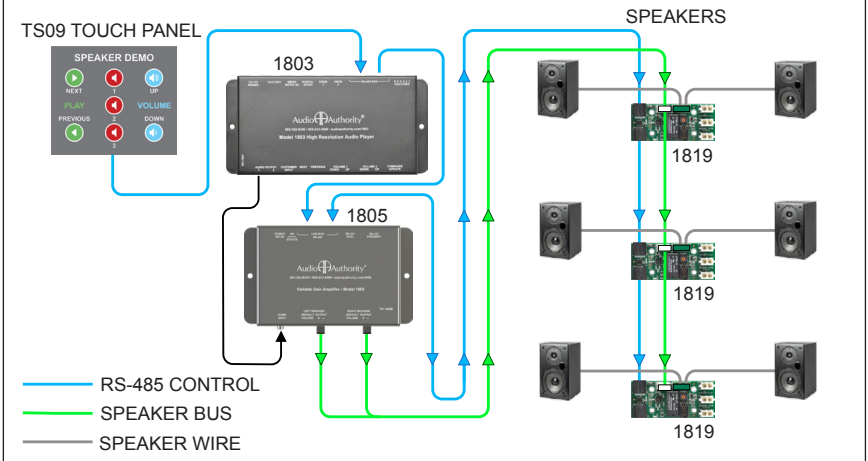

Audio Authority®

2048 Mercer Road, Lexington, KY 40511-1071 USA
 800-322-8346 • 859-233-4599 • Fax: 859-233-4510
 support@audioauthority.com • www.audioauthority.com

E-202
 Rev. 20190828