

Installing and Using the Model 1285-4 Universal Audio/Video/RF Distribution System

The Model 1285-4 active raceway and accessory units 1285B, C and E make up a system for distributing analog and digital audio, composite and component video, and antenna or cable TV signals totaling 8 channels, in home entertainment showrooms. Each section of 1285-4 active raceway provides two sets of amplified and isolated outputs per 4-foot length. Up to 10 sections may be placed end-to-end along a wall. A 1285 system is comprised of from one to ten 1285-4 raceways and one 1285E endcap set. The 1285C corner kit allows the 1285-4 raceway to turn inside and outside corners and the 1285B blank raceway may be placed between active sections.

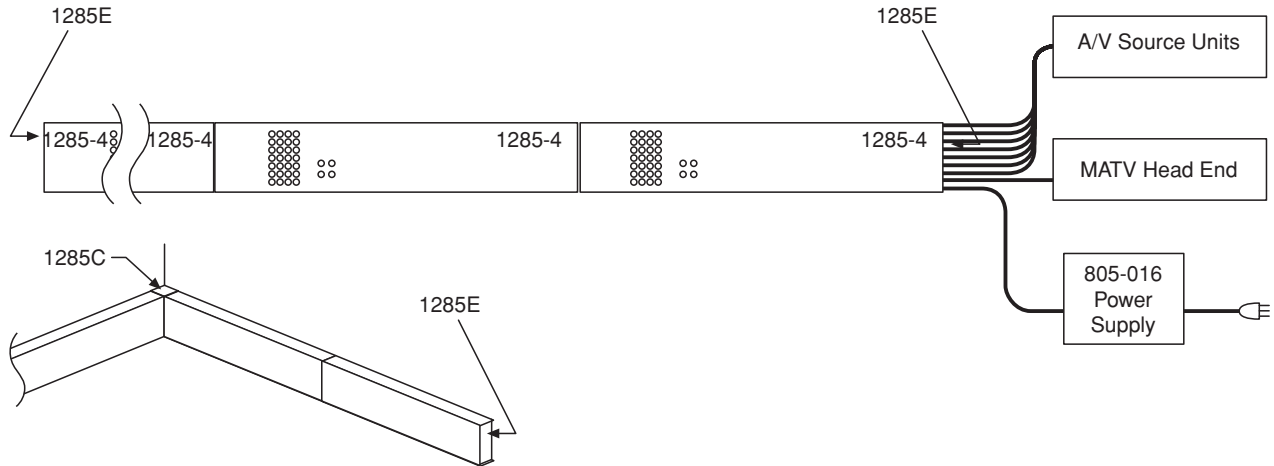

The signal path from source to last amplifier may be up to 250 feet long. Like other members of the Audio Authority 985 family, the 1285-4 provides ample bandwidth for today's high-definition televisions and faithfully reproduces the source signal at each product output. The A/V source system may have the outputs shown in the table at the right.

Stereo analog audio	2 conductors	high impedance
Digital audio	1 conductor	75 ohms
Composite video	1 conductor	75 ohms
Component video	3 conductors	75 ohms

In addition, a feed may be taken from the house MATV system in the frequency range of 5 to 1000 MHz. Set up the source and MATV feeds and conduct each one to the nearest point of the 1285-4 system, using high-quality RG-59 or 6, or Belden 1505A or 1506A cable for audio and video, and RG-6 for MATV.

Note: the tap loss of each 1285-4 MATV tap is 24 dB and the insertion loss is 0.5 dB; account for these figures in the design of the feed from the MATV headend.

Installation

1. Set the required number of sections of 1285-4 active raceway and/or 1285B blank raceway end-to-end in the area to be served. If the raceway must turn a corner, allow for a 1285C corner connector in the layout. The raceway may be cut with a cutoff saw or reciprocating saw. Snap a chalk line on the wall at the required height. Screw the first raceway section to the wall, using the supplied 1" screws in wood or composites, or with plastic anchors in gypsum board. If there is a corner, start there and use the 1285C corner connector to align the first raceway horizontally.
2. Mount the remaining sections of raceway, butting each one to the end of the previous section. Intersperse 1285B blank sections if needed. Attach a 1285E endcap on each end of the raceway and 1285C corner connectors, if any, using the supplied screws. In the case of an outside corner, drill four holes for the sheet metal screws.
3. Identify the head end, or source end, of the 1285 system. If the source feeds the right end of the 1285, no changes will be needed (see Step 5 if you are feeding from the left end). Mount F-connectors in the source endcap with the supplied nuts and lockwashers and put plastic hole plugs in the other endcap. Connect the

raceway caps (with amplifier modules) together with the coaxial cables and twisted pair power cable and secure the caps to the wall-mounted raceway. Connect the first amplifier module to the endcap F-jacks or directly to the source equipment. Note: When using 1285B blank sections, replace coaxial cables in the adjoining 1285-4 with longer cables supplied with the 1285B.

4. Plug the supplied DC power supply wire to the power header on the first amplifier module. Run the other end of it through the slotted Power port hole in the endcap and install the plastic wire clamp in the hole with pliers.
5. If the source feeds the left end, perform these two steps: a) The MATV taps are directional. When feeding from the left end, cross the input and output cables at each MATV tap as show below.

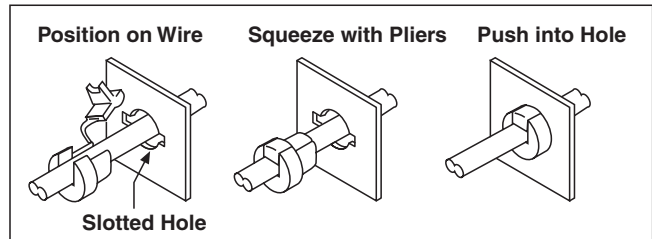

b) Remove the preassembled coaxial cables extending from the right end module of the completed raceway and install six terminators on all ports EXCEPT ANALOG AUDIO. Put leftover plastic caps on the two analog audio ports. Use the cables for left end hookup, as needed.

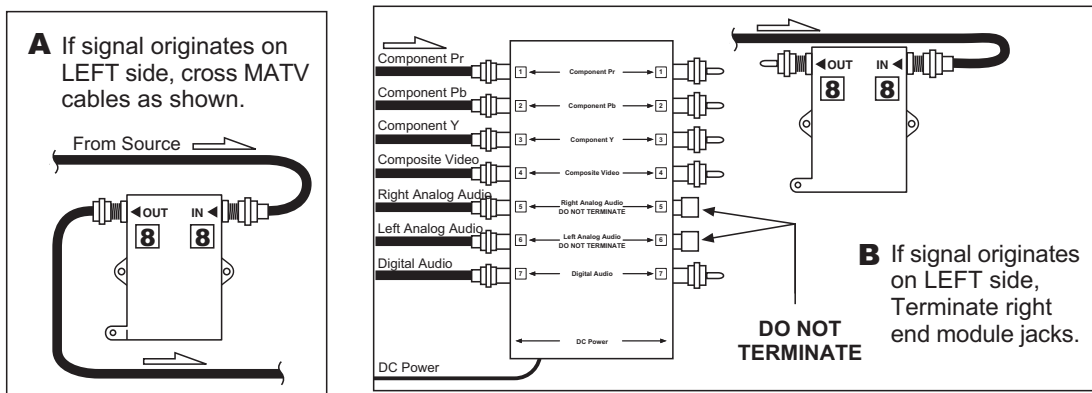

Finishing the Hookup

1. You may connect the source equipment directly to the first amplifier module on the feed end (Run cables through the knockouts in the 1285E endcaps). Alternatively, you may install the supplied F-connectors on the endcap, connecting the first amplifier to the inside of the F-connectors and the source to the outside of the F-connectors. Use the necessary adapters or made-up cables to connect the F-connectors on the amplifier to the source connectors.
2. Make sure you have installed terminators on the last MATV "out" tap and the output ports of the last amplifier EXCEPT for the analog audio ports. Six terminators are supplied, one for the MATV tap and five for the video and digital audio ports of the 1285-4 amplifier module. The plastic caps on the analog audio ports will help you remember to not terminate them.
3. Observing polarity, connect the DC power wire to a 805-016 power supply and apply power to the 1285 system. Check that the Power lamp of each section is illuminated.
4. Test outputs. If hum bars are seen in the video or you have any other difficulty, call our Tech Services hotline, 800-322-8346 for qualified assistance.



2048 Mercer Road, Lexington, Kentucky 40511-1071
 Phone: 859/233-4599 • Fax: 859/233-4510
 Customer Toll-Free USA & Canada: 800/322-8346
 Website: <http://www.audioauthority.com>

752-403
 9/01