

Installer's Reference Manual

Model 1533 Intercom / Telephone Interface

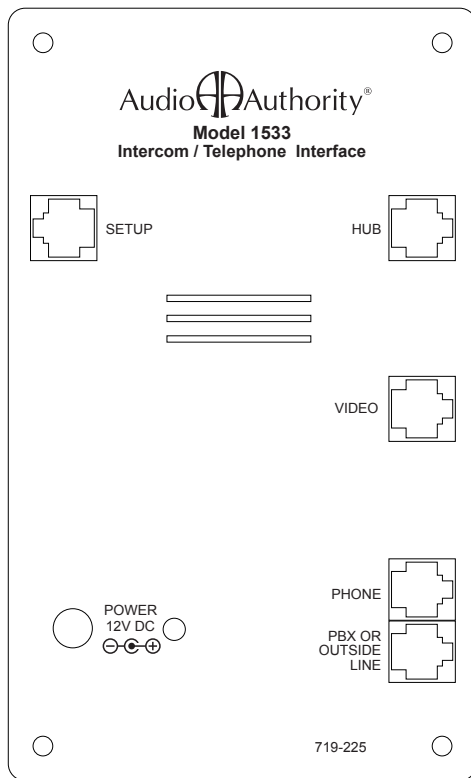

Audio  Authority[®]

Model 1533

Telephone / Intercom Interface

Table Of Contents

1.0 INTRODUCTION	3
2.0 BASIC FEATURES	8
3.0 ABOUT PHONE SYSTEMS	9
4.0 INSTALLATION	10
5.0 PROGRAMMING	10
6.0 ALTERNATE MODES AND FEATURES	18
7.0 GLOSSARY OF TERMS	22

WARNINGS

- Read these instructions before installing or using this product.
- To reduce the risk of fire or electric shock, do not expose to rain or moisture.
- This product must be installed by qualified personnel.
- Do not open the cover—there are no user-serviceable parts inside.
- Do not expose this unit to excessive heat.
- Install only in dry, indoor locations.
- Clean the unit only with a dry or slightly dampened soft cloth.

LIABILITY STATEMENT

Every effort has been made to ensure that this product is free of defects. Audio Authority cannot be held liable for the use of this hardware or any direct or indirect consequential damages arising from its use. It is the responsibility of the user of the hardware to check that it is suitable for his/her requirements and that it is installed correctly. All rights are reserved. No parts of this manual may be reproduced or transmitted by any form or means electronic or mechanical, including photocopying, recording or by any information storage or retrieval system without the written consent of the publisher.

Audio Authority reserves the right to revise any of its hardware and software following its policy to modify and/or improve its products where necessary or desirable.

Audio Authority and the Double-A Symbol are registered trademarks of Audio Authority Corp. Copyright June, 2007. All third party trademarks and copyrights are recognized.

1.0 INTRODUCTION

The Model 1533 Telephone / Intercom Interface allows *Employees* to use a telephone to communicate with Series 1500 drive up *lanes*. It serves as a Counter Station like a 1500, but the user communicates through a telephone instead of a microphone and speaker. The 1533 can also connect the intercom system to outside telephone lines to perform special functions.

The 1533 rings the designated office telephone(s) in response to *lane activity* such as when the Call button is pressed, the *lane* handset is lifted, or when the traffic sensor is triggered.

1.2 SYSTEM DESIGN CONSIDERATIONS

Series 1500 Architecture

- The 1533 performs the function of a 1500, 1500A or 1500AH Counter Station.
- Multiple 1533 interfaces can be used in one system, either with or without Series 1500 Counter Stations.
- If it is desired to conduct simultaneous conversations between employees and drive up *lanes* using the phone system, it is necessary to install one 1533 for each drive up *lane*.
- If simultaneous *lane* activity is not necessary, a single 1533 can be used to operate multiple *lanes*, similar to other Series 1500 systems.
- A 1533 must be used with a Series 1500 Hub, either a Model 1509SD or a 1510, 1511, 1512, or 1513 Hub equipped with a 1517SD system card.
- If one way or two way video is desired, an Audio/Video Hub must be used (e.g. 1510).
- The 1533 is not compatible with Series 1580 systems.

Phone System Architecture

- If communication with the *lanes* will be through corded, multi-line *office phones*, see Example 1: *Trunk Mode*.
- If communication with the *lanes* will mainly be through a *Dedicated Lane Phone* (often a cordless phone) see Example 2: *Extension Mode*.
- If communication with the *lanes* will only be through a *Dedicated Lane Phone* (often a cordless phone) not connected to any office telephone system or PBX, see 3.1 1533 Modes and Features.

EXAMPLE 1: TRUNK MODE

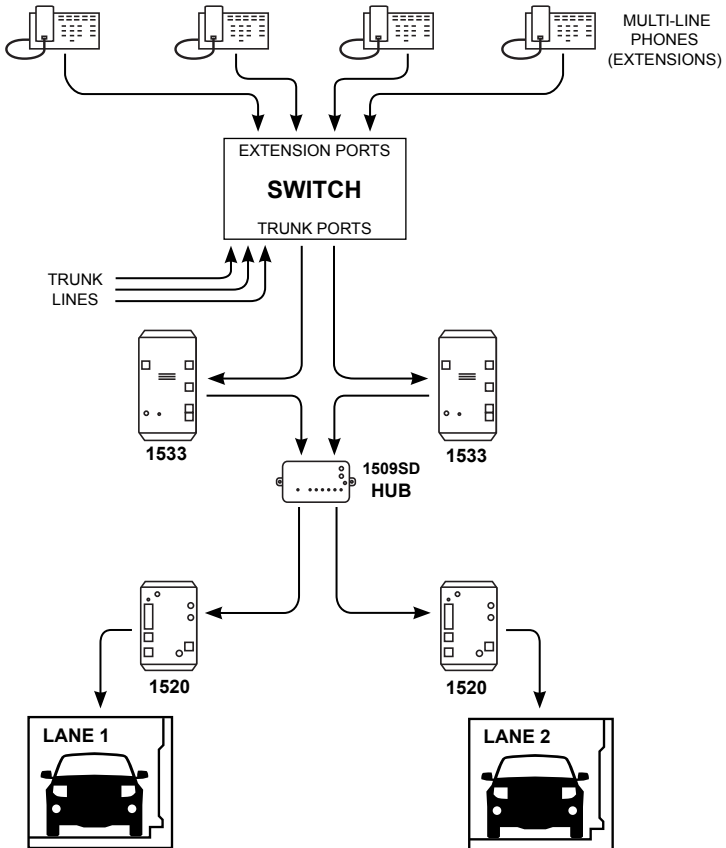

Trunk Mode Features

The 1533 Phone port is connected to a Trunk port on the PBX.

- A drive-up *lane* may be accessed by any telephone extension in the building.
- A drive-up *lane* is selected on any desk phone in the same manner as selecting an outside line (activate *Direct Lane Access*, p. 14).
- Multiple phones may conference with a customer using the PBX.
- Fully featured hunt groups can be set up in the PBX for calling drive-up *lanes*.
- No *Dedicated Lane Phone*.
- Often preferred in pharmacy installations.

EXAMPLE 2: EXTENSION MODE

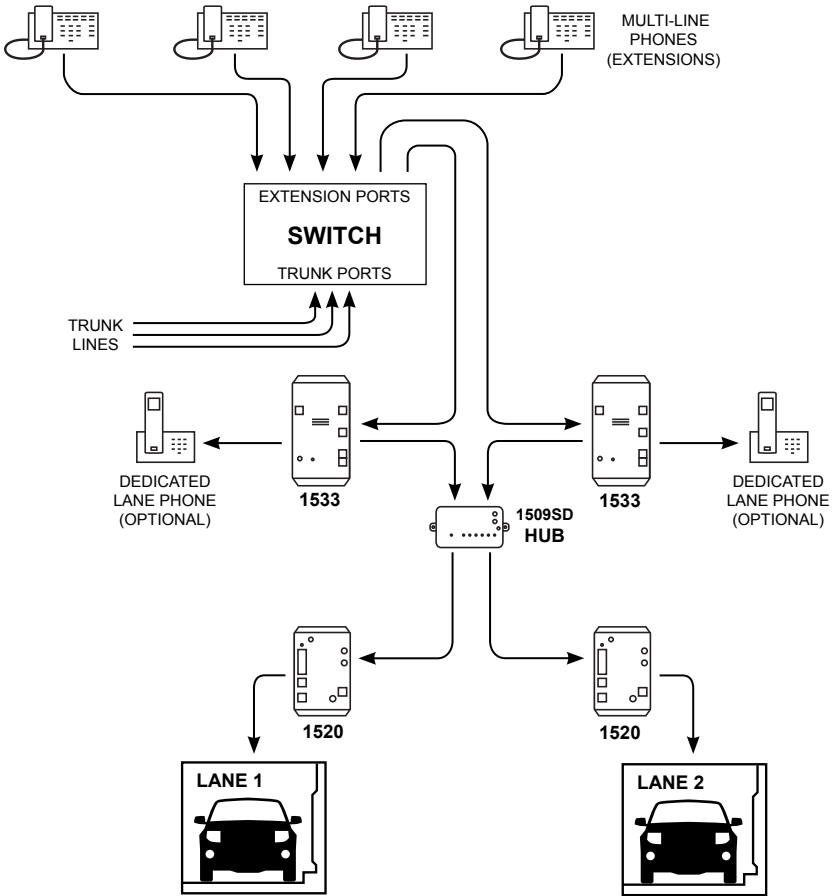

Extension Mode Features

The 1533 Phone port is connected to an **analog*** Extension Port on the **PBX**.

- Each 1533 can support a *Dedicated Lane Phone* roaming (can be cordless).
- The *Dedicated Lane Phone* (optional) can access an outside line.
- Phones inside or outside the premises call drive-up *lanes* by extension number (activate *Direct Lane Access*, p. 14).
- A drive-up *lane* may be programmed to automatically call any phone number when the Call button is pushed (such as during off-hours).
- Each *lane's* "hunt group" includes only the *Dedicated Lane Phone* and one predetermined extension. See "Ring to Forward", p. 15.
- Often favored in bank installations.

*See section 3.0 About Phone Systems.

EXAMPLE 3: TRUNK MODE WITH ONE 1533

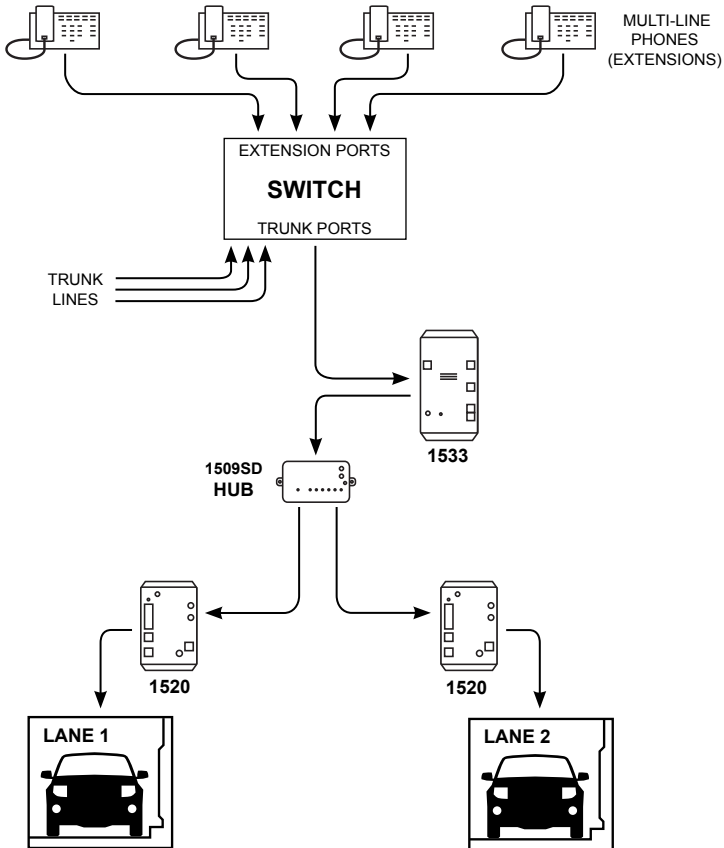

One 1533 Operating Multiple Lanes (*Trunk Mode*)

The 1533 Phone port is connected to a Trunk port on the *PBX*.

- One 1533 may be used to operate two or more *lanes*, but only one *lane* may be active at any one time.
- A drive-up *lane* may be accessed by any telephone extension in the building.
- A drive-up *lane* is selected on any desk phone by pressing a feature key that has been programmed to connect to the 1533 and then choose a *lane*. See 3.2 *PBX* Programming.
- Multiple phones may conference with one customer using the *PBX*.
- Fully featured hunt groups can be set up in the *PBX*.
- No *Dedicated Lane Phone*.
- Often preferred in pharmacy installations.

EXAMPLE 4: EXTENSION MODE WITH ONE 1533

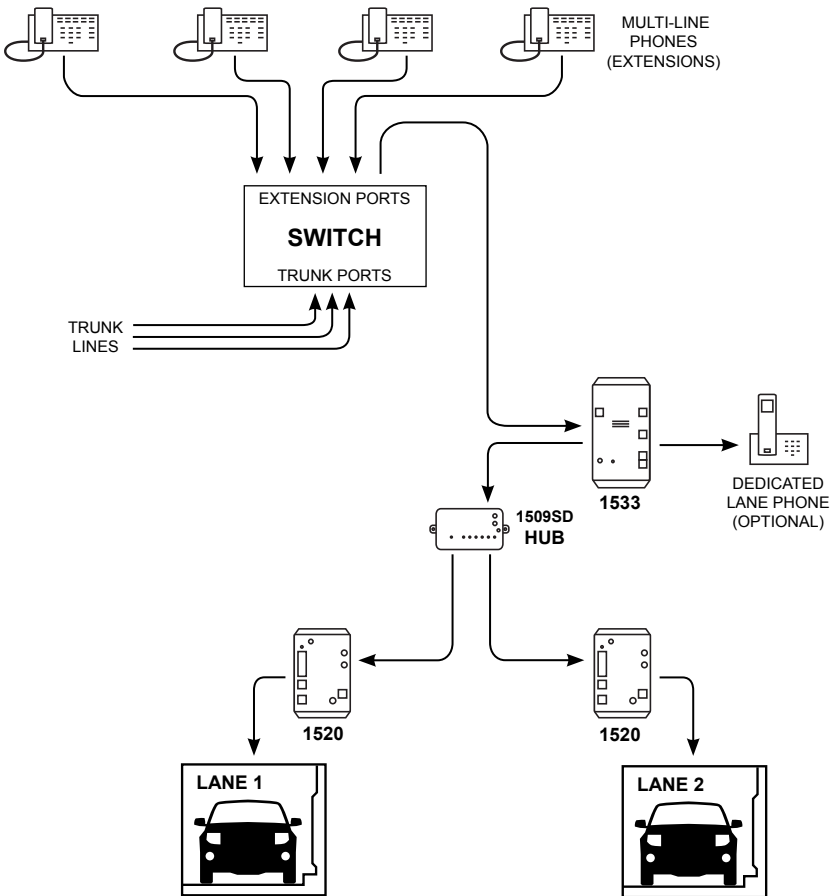

One 1533 Operating Multiple Lanes (*Extension Mode*)

The 1533 Phone port is connected to an Extension port on the *PBX*.

- One 1533 may be used to operate two or more *lanes*, but only one *lane* may be active at any one time.
- Each 1533 can support a *Dedicated Lane Phone* roaming (can be cordless).
- The *Dedicated Lane Phone* can access an outside line.
- Phones inside or outside the premises call drive-up *lanes*.
- A drive-up *lane* may be programmed to automatically call any phone in the world when the Call button is pushed (such as during off-hours).
- Each *lane's* "hunt group" includes only the *Dedicated Lane Phone* and one predetermined extension. See "Ring to Forward", p. 15.
- Often favored in banking installations.

2.0 BASIC FEATURES

Lane to Employee Call - *Lane* activity triggers the built-in 1533 chime or causes an office phone or phones to ring. Hunt Groups can be set up to ring one set of phones, and if not answered within a certain number of rings, another set of phones ring.

Employee to Lane Call - Lanes may be contacted by any office phone. It is usually desirable to set up the *PBX* so that a single button press on an office phone initiates contact directly to the *lane* (see 3.2).

Adjusting Live Volume - If the telephone lacks a volume control, listening volume may be temporarily adjusted during a conversation with a *lane* using the phone's keypad. The **3** key increases volume, the **6** key reduces volume. There are six steps for this volume control. Bear in mind that the key tones are heard at the *Lane Station* and may be annoying to the customer. This volume level can also be more permanently adjusted from the *Dedicated Lane Phone* (but not a *Remote Phone*) as described in Section 5.8 "Programming Employee-Configurable Parameters" section.

Hunt Groups - The 1533 works with *PBX* systems to enable hunt groups when there is *lane activity* (handset lifted, traffic sensed, or Call button pressed). The *PBX* may be programmed to ring a primary hunt group for a set number of rings, and then ring a secondary group, etc. (This function is distinct from Ring to Forward and Night Mode, which are 1533 functions).

Relay Activation - (Use # key) If *Lane Station* relay contacts are connected to a door latch or other device, the 1520 *Lane Station* can activate the relay. In systems with a Counter Station, the relay is operated via the Hold key. In 1533 systems, the # key performs the same function during a *lane* call. This function is not available from a remote phone.

Conference with Lane - Using the *PBX* conference feature, multiple office personnel may communicate with the same *lane*.

One-way and Two-way Video – A wall-mounted 1501W plugged into the 1533 permits the customer to be seen by employees; a 1502W allows customer and employee to see each other.

Wireless Headset – With a desk phone connected to the Phone port and a wireless headset installed on the desk phone, the employee can roam while serving customers. This configuration could also be used with *Trunk Mode*, but does not allow as much functionality as the cordless *Dedicated Lane Phone*.

See 6.0 for special features available.

3.0 ABOUT PHONE SYSTEMS

This manual assumes the 1533 is connected via a trunk port (*Trunk Mode*) on a PBX or KSU telephone switch unless otherwise specified.

Model 1533 was designed for the most nearly universal interface—the public analog telephone network. Business phone systems range from the simplest, two-line desk phone to complex multi-line systems with many extensions.

3.1 1533 MODES AND FEATURES

There are three installation “modes” or ways to connect and set up the 1533. Different features are available, depending on the Mode used. This manual concentrates on Trunk Mode wiring and setup. See 6.0 for other Modes and features.

Trunk Mode - Connect the 1533 to a Trunk or “CO” port on an office phone system. See *Trunk Mode* wiring detail on page 16.

Extension Mode - Connect the 1533 to an analog extension port* on a phone system. See 6.1 for wiring detail and *Extension Mode* special features.

Single Line Mode - Connect an ordinary public telephone line directly to the 1533. Wiring is similar to *Extension Mode* – see page 21.

3.2 PBX PROGRAMMING

The 1533 can be installed and programmed by a Series 1500 intercom installer, but for advanced phone system features such as those listed below, a qualified telephone system technician is required.

Hunt Groups – In *Trunk Mode*, *Lane Activity* can trigger one phone to ring or several phones. In this document, a Hunt Group refers to the phone or phones that ring first and the number of unanswered rings before ringing another phone or group of phones.

Conferencing – The PBX may be programmed to allow two Office Phones to conference with a *lane*.

Programed Lane Key – When using one 1533 to operate two or more *lanes*, it is suggested that one feature key on the telephones be programmed to connect directly to each *lane* with a single button press. If this is not done, the operator must perform a two-step process to contact a *lane* (select trunk port, then chose *lane* number).

* The 1533 is not compatible with **digital** extension ports. Often, digital telephone switch systems already have one or more analog cards installed for use with faxes, modems or other analog devices, so vacant analog ports may already be available for 1533 connection. If a telephone switch does not have an analog port, an analog card can usually be installed in the telephone switch's central switching unit.

4.0 INSTALLATION

Model 1533 offers a number of connection alternatives, depending on the application. Begin the installation by choosing one of the simplified example configurations on pages 4-8 as a model for your application. Adapt it to your needs, considering the number of *lanes*, and the number of 1533 units that will provide sufficient capacity for employees and customer traffic. Next, check that the office telephone system has enough vacant ports for the number of 1533 units to be connected. Install extra cards in the *PBX* if necessary.

1500 System Setup

The 1500 Series Hub, *Lane* Stations, and Counter Stations should be installed, set up, and tested before adding and programming a 1533. If a Counter Station is not specified for the installation, a Series 1500 Counter Station must be temporarily connected in order to use the 1550 (see 5.0 Programming).

1533 Wiring

Mount the 1533 in a convenient location (see below) and connect to the 1500 system with Cat 5e/6 cable (see page 16). Connect to the phone system using standard 2- or 4-conductor line cord, or for longer distances, use Cat 3 cable with 6P6C plugs. Power up all system components and perform programming.

1533 Location

If the chime (located on the front of the 1533 case) is used as the primary alert to *Employees* of customer activity, mount the 1533 where its chime may be heard by *Employee*. If video monitors are used, mount the 1533 nearby. Otherwise, the 1533 may be located in an equipment closet.

5.0 PROGRAMMING

Three levels of programming, *performed in the following order*, are required for proper system installation:

1. Basic Series 1500 parameters performed using a 1550 Field Setup Display Tool connected to a Model 1500, 1500A or 1500AH; see the Series 1500 manual.
2. 1533 advanced parameters accessible only by the installer with a 1550 connected to the 1533 Setup port.
3. 1533 parameters that the *Employee* can adjust (without a 1550) see 5.8.



NOTICE: Each 1533 must be set up individually within a system. A 1550 connected to a 1533 allows programming of that 1533 only. All other intercom system programming must be accomplished by connecting the 1550 to a Series 1500 Counter Station.

In a Series 1500 intercom system, most parameters that affect the operation of the system are stored in the hub unit. Special 1533 parameters are stored inside the 1533, instead of the Hub, to simplify programming of other devices in the 1500 system. As a result, when a 1533 is installed in the place of a Model 1500 Counter Station, the Hub ignores the original Counter Station parameters for that position and uses the parameters stored inside the 1533 instead.

Note that if a 1533 is replaced in the field, it is necessary to re-program the new 1533 to restore customer preferences. Reprogramming is not necessary when swapping out a Model 1500 Counter Station or Model 1520 Lane Station, because their operating parameters are stored in the Hub.

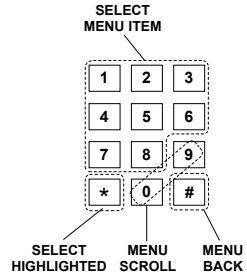

5.2 HOW TO ADJUST ADVANCED PARAMETERS

To program the 1533 advanced parameters, plug Model 1550 into the 1533 Setup port. Connect an analog phone to the 1533 Phone port, and dial ## 2 2 on the keypad. The 1550 shows the root menu (see page 13 for a complete menu tree).

Navigating the Menu

While in any menu, the following phone keys are active:

- Keys 1 through 8** - Make that menu selection, if available
- Keys 9 and 0** - Scroll up or down through menus
- *** - Select the menu item indicated by the blinking cursor
- #** - Go back to the previous menu (no effect in root menu)

Five menus are accessed from the root menu:

- 1: System Parameters
- 2: Lane Parameters
- 3: Telephone Line Parameters (*used only with Outside Line*)
- 4: Set Defaults
- 5: Exit

Parameters in the first three sub-menus are described in detail on the following pages. Factory defaults can be quickly restored in Menu 4, and Menu 5 returns the user to normal operation.

Note: When programming System, Lane, or Telephone Line Parameters, it is necessary to exit via menu 5 in order to save all editing changes. If the programmer hangs up the phone before exiting, all changes will be lost.

Adjusting Parameters

While editing any parameter (except security code and outbound number, described below), the following keys are active:

Keys 3 and 6 - Increase or decrease value (or turn on/off).

- Finish editing parameter and return to menu.

Keys 1 and 4 - (for *lane* parameters only) increase or decrease *lane* number being edited.

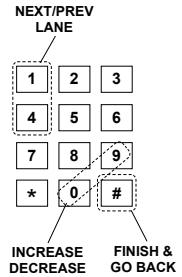

While editing the security code or outbound number, use the following keys:

Keys 0 through 9 - Insert digit.

***** - Insert “star” digit.

- Special function. When followed by an additional keystroke, # performs the following functions:

1 - Erase last digit entered (backspace).

2 - Exit editing parameter and return to menu.

- Insert “pound” digit.

3 - Insert a 2-second PAUSE in the dial string (for outbound number only).

ADVANCED PARAMETER MENU TREE

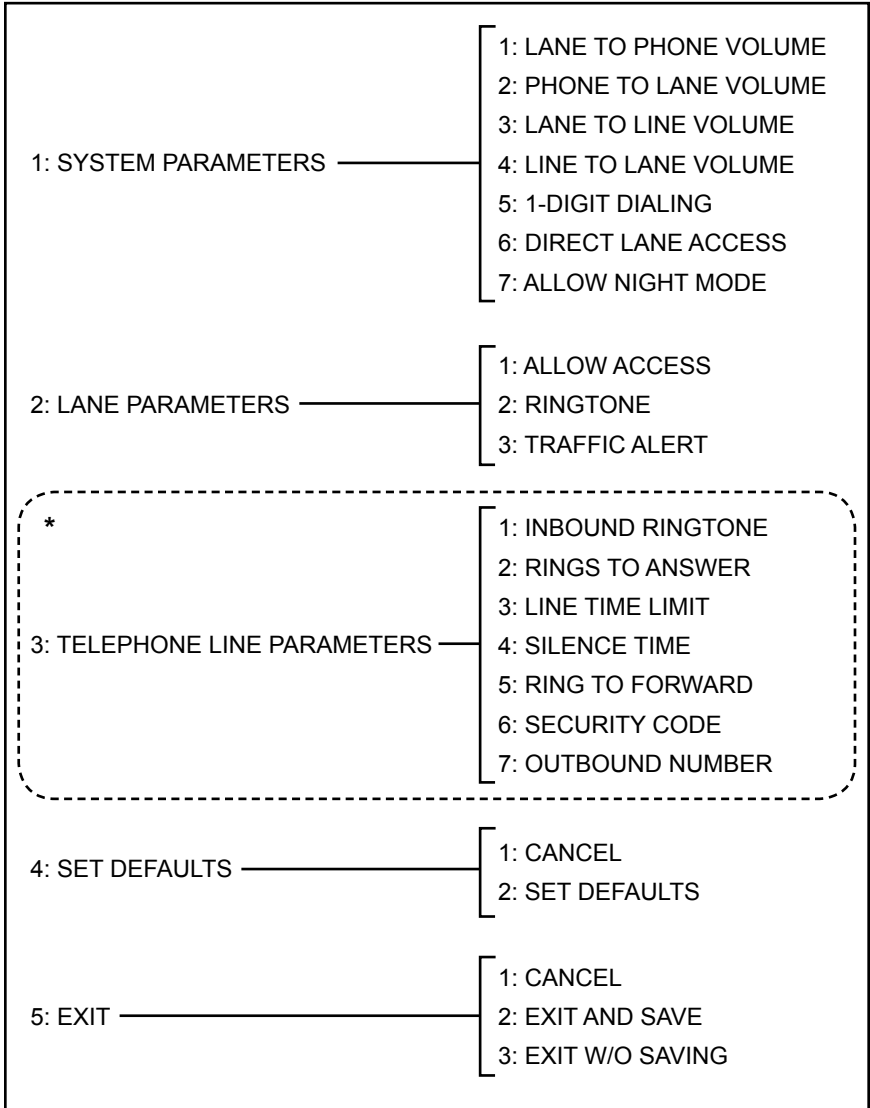

* Telephone Line Parameters

The Telephone Line Parameters are used only if an outside line is connected to the 1533 *PBX* port. If no outside line is connected, leave all the Telephone Line Parameters at their factory default setting.

5.3 SYSTEM PARAMETERS

Advanced Parameters are intended to be configured by a system administrator or installer and require a 1550 LCD and analog phone to be attached, similar way to Counter Station programming. Each 1533 must be programmed separately.

Lane to Phone Volume - sets the level of *Lane* audio as heard on the *Office Phone* or *Dedicated Lane Phone* (Default = 6).

Phone to Lane Volume - sets the level of *Office Phone* or *Dedicated Lane Phone* audio as heard at the *Lane Station* (Default = 6).

Lane to Line Volume - (*Outside Line* feature) sets the level of *Lane* audio as heard at a *Remote Phone* (Default = 10).

Line to Lane Volume - (*Outside Line* feature) sets the level of *Remote Phone* audio as heard at the *Lane Station* (Default = 6).

1-Digit Dialing - (*Dedicated Lane Phone* only) in systems with 8 or fewer *lanes*, dial one *lane* digit. If disabled, two digits must be dialed, and a leading zero (example: 06) must be used when accessing *lanes* 1-9. (Default = ON). Not applicable to Office Phones.

Direct Lane Access - If enabled, sends incoming calls directly to a specified *lane*. If disabled, prompts the caller with a dial tone to dial a *lane* number (default = DISABLED).

Allow Night Mode - (*Outside Line* feature) allows Night Mode to be activated by an *Employee*. When activated, the 1533 will dial a preset outside number (see below) upon detecting *lane* activity. (Default = OFF).

5.4 LANE PARAMETERS

Note: Each *lane* can be configured individually.

Allow Access - Specifies the set of *lanes* to which each 1533 is allowed access. Use this feature to distribute responsibility over *lanes* to multiple 1533 units or Counter Stations. (Default is ON for Lanes 1-4, and OFF for Lanes 5-16)

Ringtone - The sound heard through the 1533 chime speaker that indicates *lane* activity. Use the standard ringtone or apply unique ringtones for audible *lane* identification. See "Standard Ringtone" below. (Default is STANDARD for *lanes* 1-16)

Traffic Alert - Each *lane* can be configured to alert *Employees* when a traffic sensor detects a vehicle. Options are NONE, CHIME or RING. CHIME rings the 1533 chime speaker, and RING rings the phone or the phone(s) as programmed in the *PBX*. If the traffic alert is set to RING it triggers the same functions as the Call button. As a result, it activates Night Mode and Ring to Forward when used with an outside line. (Default is NONE for *lanes* 1-16)

5.5 TELEPHONE LINE PARAMETERS

All parameters in this section require an *Outside Line*. See 6.2 for details.

Inbound Ringtone - allows an incoming call to have a unique ringtone (heard through the 1533 chime speaker), or can be configured to use the standard ringtone (default = RINGTONE 16).

Rings to Answer - can be programmed to automatically answer an incoming call (see 5.3 Direct *Lane* Access) during the first ring, after rings 1-15, or not to answer at all (default = DISABLED).

Line Time Limit - Allows the duration of any *lane*-to-telephone line call to be limited to between 1 and 120 minutes in steps (see 6.2). Can be disabled (default = 2 MINUTES).

Silence Time - Allows any *lane*-to-telephone line call to be hung up if a period of silence or constant volume (dial tone, noise, etc.) is encountered. This time is selectable in multiples of 20 seconds from 20-300 seconds (see 6.2). Can be disabled (default = 60 SECONDS).

Ring to Forward - If a *lane* call is not answered within the set number of rings, the call transfers to a pre-programmed number (see Outbound Number below). If the system is set to Night Mode, or Ring to Forward is set to zero, the transfer to a pre-programmed number is immediate. (default = OFF).

Security Code - if activated, requires a security code of up to eight digits to be entered by the caller before connecting with a *lane* or prompting with dial tone (default = 12345).

Outbound Number - When Night Mode is activated, the 1533 dials this number when *Lane Activity* is detected. The outbound number is up to 16 digits in length, with provision for 2-second pauses to allow access through a *PBX* (default = NO NUMBER SPECIFIED).

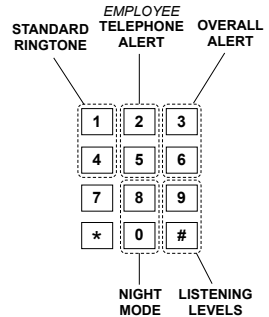

5.6 SET DEFAULTS

Set Defaults - Resets all parameters to factory default values.

5.7 EXIT

Exit And Save - Saves changed parameters to the 1533 and exits Setup.

Exit Without Saving - Exits Setup Mode without saving any parameter changes.

TRUNK MODE WIRING DETAIL

Connections below represent a basic installation using *Trunk Mode*.

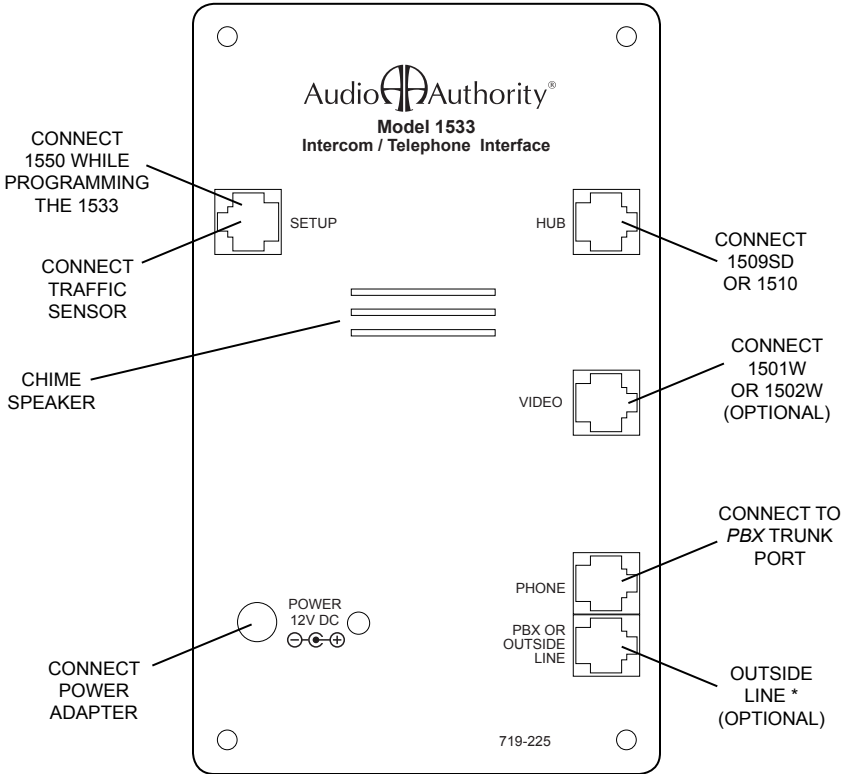

* This port may be used for communication from drive-up *lanes* to an outside line. See 6.2 *Outside Line* Features.

5.8 EMPLOYEE-CONFIGURABLE PARAMETERS

The following *Employee*-configurable parameters are accessed by a *Dedicated Lane Phone* or *PBX* extension. To make adjustments, dial # # 2 2 *without* a Model 1550 Field Setup Display Tool connected to the 1533.

Standard Ringtone - the default ringtone used by this 1533 for *lane* and incoming call alerts, heard through the 1533 chime speaker.

Keys 1 and 4 - Select one of 16 different melodies to be the 1533 ringtone (default = RINGTONE 1).

Handset Alert Volume - Controls the level of alert tones sent to Office Phones or the *Dedicated Lane Phone* (default = 9).

Keys 2 and 5 - Increase and decrease the *Dedicated Lane Phone* alert level (16 levels).

Alert Volume Level - the overall alert volume level including the 1533 chime speaker *and* the volume level of the *Office Phone* or *Dedicated Lane Phone* earpiece alert (default = 1).

Keys 3 and 6 - Increase and decrease the overall alert level (4 levels).

Phone Listening Volume Level - Permanent adjustment of audio from *lane* as heard on the phone handset. Applies to Office Phones, *Dedicated Lane Phone*, and Remote Phones. See also page 8, Adjusting Live Volume. (default = 3).

Keys 9 and # - Increase and decrease the phone listening levels.

Night Mode - If Night Mode is allowed (see 6.2), the *Employee* can activate and deactivate it from an *Office Phone* or *Dedicated Lane Phone* (default = OFF). The Night Mode keys play an ascending or descending melody when the mode is activated or deactivated, respectively.

Keys 8 and 0 - Activate and deactivate Night Mode (if allowed). If Night mode is not allowed, these keys have no effect (see “Allow Night Mode” in 5.3 System Parameters).

The *Employee* can hang the phone up after programming to retain all new values in memory.

6.0 ALTERNATE MODES AND FEATURES

Extension Mode – Recommended when an employee must communicate with the *lanes* from a cordless phone (*Dedicated Lane Phone*). The diagram at the right shows basic *Extension Mode* connections.

Single Line Mode – Identical to *Extension Mode*, except that the 1533 is connected to a dedicated phone line instead of an Extension Port on the *PBX*.

Outside Line – An outside line may be connected when using *Trunk Mode* or Single Line Mode. *Outside Line* features are available in *Extension Mode*, but signals are routed through the *PBX* to access the outside line.

Is My Telephone System Compatible for *Extension Mode*?

To determine whether or not your phone system will support the 1533 in *Extension Mode*, plug in a standard, residential telephone. (This type of phone is always analog.) If you hear a dial tone, the 1533 will work on that jack of the *PBX*.

6.1 USING a Dedicated Lane Phone

A *Dedicated Lane Phone* may only be used with *Extension Mode* or Single Line Mode. It must be an analog telephone, and can be corded or cordless.

Lane to Dedicated Lane Phone - The 1533 chime and *Dedicated Lane Phone* ring in response to *lane* activity. If the *Dedicated Lane Phone* has Caller ID, its display indicates the calling *lane*. To communicate with the *lane*, the employee may either answer the call as usual or, if the employee is already on another call, place the current call on hold using a *Hook Flash* and dial the *lane* number of the new customer.

Dedicated Lane Phone to Lane - The Staff may initiate contact with a *lane* from the *Dedicated Lane Phone* by dialing the *lane* number.

Outside Line to Dedicated Lane Phone -

Incoming calls to the 1533 extension will ring the *Dedicated Lane Phone*. The call can be picked up normally by pressing the Talk or Phone key.

Dedicated Lane Phone to Outside Line - The

Staff may access an outside telephone line directly from the *Dedicated Lane Phone* by dialing 9.

Call Waiting - If the *Dedicated Lane Phone* connected to the 1533 is in use, and a telephone

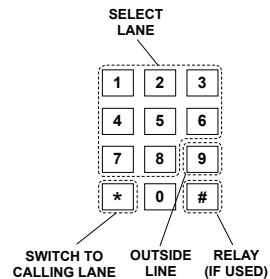

line or *lane*-initiated call rings in, the user hears a call waiting tone from the 1533 chime speaker. The *Employee* can then put the original call on hold by performing a *Hook Flash*, and then select a *lane* by dialing the *lane* number. If the *Dedicated Lane Phone* hangs up and there is a pending call from a *lane* station, the *Dedicated Lane Phone* immediately rings. As an alternative, switch directly from one *lane* to the next calling *lane* by pressing the * key.

Hold - Any time the *Dedicated Lane Phone* is in use, the call can be put on hold by performing a *Hook Flash*. This places the call (*lane* or outside line) on hold. The *Dedicated Lane Phone* then produces a dial tone, and can dial a *lane* or outside line as usual. After 90 seconds on hold, a reminder tone is heard on the *Dedicated Lane Phone*. Additional tones are heard at 120 seconds and 135 seconds. If the call on hold has not been picked up after 150 seconds, the call is disconnected. To return to a caller placed on hold, either perform another *Hook Flash* or dial the number of the *lane* on hold.

6.2 OUTSIDE LINE FEATURES

The following features are available in *Trunk Mode*, *Extension Mode* and Single Line Mode, as long the 1533 has access to an outside line through the 1533 *PBX* port:

Lane to Outside Line - The 1533 can be configured to automatically dial an outside number through the *PBX* port when there is *lane* activity (handset lifted, traffic sensed, or Call button pressed), and connect the calling *lane* to the dialed number (see Rings to Forward, Night Mode, and Outside Number for more information).

Idle Timeout - The 1533 listens to the signal volume of telephone calls. If there is very little volume for the duration of time programmed by the parameter "Silence Time Limit for *Lane* Access" (see Section 5.5 Telephone Line Parameters), the 1533 prompts both parties with a "hurry-up" tone. If no significant signal is heard within 10 seconds, the call is dropped to prevent the line being tied up accidentally. If a signal of sufficient volume is detected, the timer is reset and will start over for the specified time.

Special facilities are provided for *Lane* to *Remote Phone* connections to prevent a call from tying up the line after the call is completed and to prevent a call from being terminated prematurely:

- The 1533 monitors loop current and releases the line if the loop current is interrupted for more than one-half second.
- The 1533 monitors the audio content of the call, determines if the activity represents dial tone, busy signal, ringback, speech, modem or silence, and takes action accordingly.
- If line noise or other anomaly prevents normal call termination, the predetermined telephone line time limit will force a line release.

Outside Line to Lane - 1533 systems can be configured to route an incoming telephone call directly to a *lane*. This feature can be used either with or without a user selectable security code (see below).

- Any phone in the office (or other remote location) can connect to a drive-up *lane* or can call any phone.
- If so configured, the 1533 will answer an incoming call from the off-site phone and connect the caller to a pre-determined *lane* or allow the caller to select a *lane*, depending on Direct Lane Access (see p.14).
- A security code may be programmed to prevent unauthorized access to the facility's drive-up *lanes*; if a security code is implemented, the caller must enter the code at the beginning of the call in order to reach a *lane*.

Security Code - The 1533 may be programmed to prompt for a security code when receiving a call from an outside line. If the caller pauses more than 2 seconds between digits, previous digits are ignored. This pause is helpful in the event the caller mis-dials the security code. He or she can wait 3 seconds, then re-enter the security code without having to hang up and dial back in.

Night Mode - The 1533 may be configured for "Night Mode" to handle after hours activity. In Night Mode, the 1533 routes a *lane*-initiated call to a pre-programmed telephone number. There are two indications that a 1533 is operating in Night Mode. First, the 1533 Power light blinks twice every few seconds, instead of once, as it does in normal operation. Second, when the *Dedicated Lane Phone* is used, the operator hears a "stutter" dial tone as a reminder that the 1533 is in Night Mode. See also Ring to Forward (p. 15).

ALTERNATE WIRING DETAIL

Connections below represent a basic installation using *Extension Mode* (also applies to Single Line Mode).

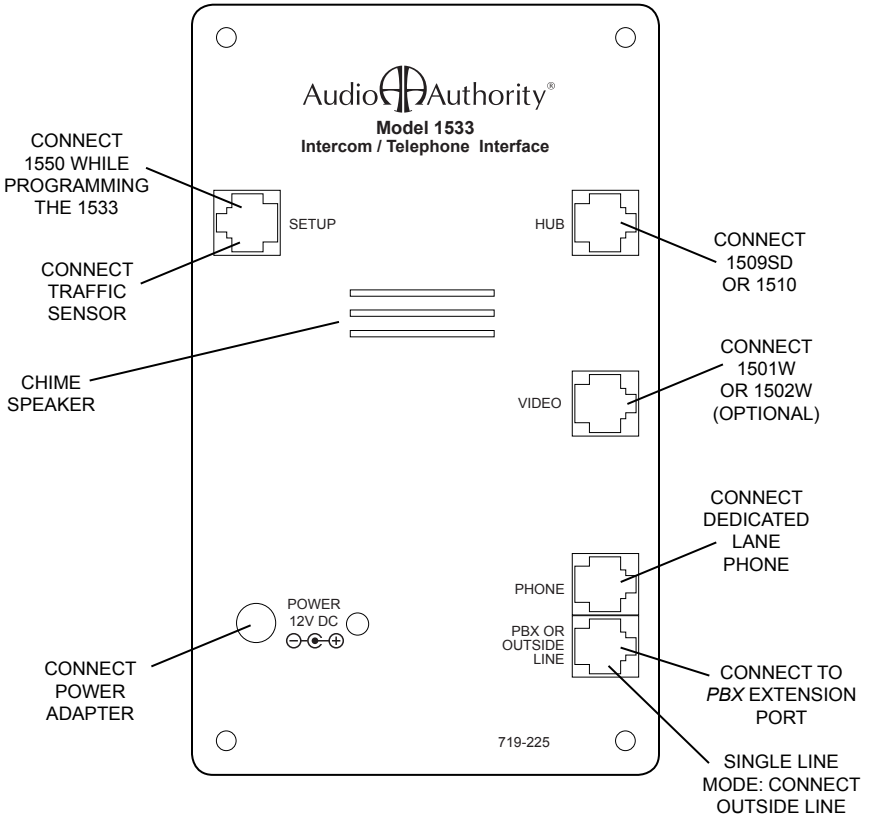

7.0 GLOSSARY OF TERMS

Employee	In this document, “ <i>Employee</i> ” means the person(s) communicating with a drive up <i>lane</i> , whether through a 1500 Counter Station, through an <i>Office Phone</i> connected by means of a premise phone system, the public phone network, or a <i>Dedicated Lane Phone</i> plugged into the 1533.
Extension Mode	The 1533 Phone Port is connected to an Extension Port on the <i>PBX</i> (see p. 5).
Hook Flash	Quickly depressing and releasing the hook on the telephone base or pressing the Flash button on a cordless handset.
Lane	Customer drive-up or walk-up unit. Also refers to a 1520.
Lane Activity or Lane Call	Any indication that a customer needs assistance, e.g. pressing the Call button, tripping the traffic sensor, or picking up the <i>lane</i> handset.
Office Phone	A phone connected to an Extension port on the <i>PBX</i> , usually a multi-line, corded telephone.
Outside Line	A public telephone company line connected either directly to the 1533 <i>PBX</i> port, or indirectly through a <i>PBX</i> Extension port.
PBX	An on-premises multi-line telephone system (can also refer to a Key System Unit or KSU) supporting analog trunks or extensions.
PBX Port	The jack in the lower right corner of the 1533 below the PHONE jack.
Dedicated Lane Phone	A corded or cordless telephone (analog) attached to the Phone port on the 1533. The <i>Dedicated Lane Phone</i> will most likely be operated by personnel on-site wishing to roam away from their workstation while maintaining communication with the Drive-up <i>Lane</i> or an outside phone line. A <i>Remote Phone</i> can be used for off-site communications with a Drive-up <i>Lane</i> or the <i>Dedicated Lane Phone</i> .
Remote Phone	A telephone or automated telephone device either on the premises, or outside the building. Connects through the <i>PBX</i> port on the 1533 (outside line).
Trunk Mode	The 1533 Phone Port is connected to a Trunk (CO) port on the <i>PBX</i> (see p. 4).

Customer information required for Telephone Terminal Equipment approved for connection to the Public Switched Telephone Network pursuant to 47 CFR § 68.218 (b) (1)

General requirements for all equipment:

This equipment complies with Part 68 of the FCC rules and the requirements adopted by the ACTA. On the back of this equipment is a label that contains, among other information, a product identifier in the format US:320NI09B1533. If requested, this number must be provided to the telephone company.

Applicable registration jack USOCs (Universal Service Order Codes) for this equipment is RJ11C.

A plug and jack used to connect this equipment to the premises wiring and telephone network must comply with the applicable FCC Part 68 rules and requirements adopted by the ACTA. A compliant telephone cord and modular plug is provided with this product. It is designed to be connected to a compatible modular jack that is also compliant. See installation instructions for details

The REN is used to determine the number of devices that may be connected to a telephone line. Excessive RENs on a telephone line may result in the devices not ringing in response to an incoming call. In most but not all areas, the sum of RENs should not exceed five (5.0). To be certain of the number of devices that may be connected to a line, as determined by the total RENs, contact the local telephone company. For products approved after July 23, 2001, the REN for this product is part of the product identifier (US:320NI09B1533) that has the format US:AAAEQ##TXXXX. The digits represented by ## are the REN without a decimal point (e.g., 09 is a REN of 0.9).

If this equipment (Model 1533) causes harm to the telephone network, the telephone company will notify you in advance that temporary discontinuance of service may be required. But if advance notice isn't practical, the telephone company will notify the customer as soon as possible. Also, you will be advised of your right to file a complaint with the FCC if you believe it is necessary.

The telephone company may make changes in its facilities, equipment, operations or procedures that could affect the operation of the equipment. If this happens the telephone company will provide advance notice in order for you to make necessary modifications to maintain uninterrupted service.

If trouble is experienced with the Model 1533 telephone station interface, for repair or warranty information, please contact Audio Authority Corp., Lexington, KY telephone: 859-233-4599. If the equipment is causing harm to the telephone network, the telephone company may request that you disconnect the equipment until the problem is resolved.

Connection to party line service is subject to state tariffs. Contact the state public utility commission, public service commission or corporation commission for information.

If your facility has specially wired alarm equipment connected to the telephone line, ensure the installation of the 1533 does not disable your alarm equipment. If you have questions about what will disable alarm equipment, consult your telephone company or a qualified installer.

Electrical Safety Advisory:

As Electrical surges, typically lighting transients, are very destructive to customer terminal equipment that is powered by AC power sources, the customer is advised to provide a surge arrester on the AC mains supply.

Audio  Authority®

2048 Mercer Road, Lexington, Kentucky 40511-1071

Phone: 859/233-4599 • Fax: 859/233-4510

Customer Toll-Free USA & Canada: 800/322-8346

Website: <http://www.audioauthority.com>