

---

# ***Access***<sup>TM</sup>

## ***Demonstration Network***

### **Car Audio System Installation Manual**

---



2048 Mercer Road, Lexington, Kentucky 40511-1071  
Phone: 859-233-4599 • Fax: 859-233-4510  
Customer Toll-Free USA & Canada: 800-322-8346  
Website: <http://www.audioauthority.com>

The Access<sup>TM</sup> Demonstration Network is protected by U.S. Patent numbers 5,422,631 and 5,646,602 with foreign patents pending.

Audio Authority, and the double-A symbol are registered trademarks of Audio Authority Corporation. Access, AccessEZ, AccessPC, SilenTouch, AutoDamping, AutoLimiting, AutoCal, and TheftAlert are trademarks of Audio Authority Corporation. The software imbedded within the Access<sup>TM</sup> System is not sold, but rather licensed for this product specific use. The original purchaser is licensed to use this software in this product and this application only. Under this license, the software may not be reproduced, copied, disassembled, distributed by any means, licensed, rented, sold, or in any way revealed to or used by a third party.



# Contents

## Orientation

<i>INTRODUCTION</i> .....	4
<i>DEFINITION OF TERMS</i> .....	5
<i>HOW THE ACCESS™ SYSTEM WORKS</i> .....	7
<i>ACCESS SYSTEM COMPONENTS</i> .....	8

## Planning

<i>CHOOSING THE CORRECT SWITCHING MODULES</i> .....	12
<i>HEAD UNITS</i> .....	12
<i>PROCESSORS, EQUALIZERS AND BYPASS</i> .....	12
<i>AMPLIFIERS AND AMP SHARING</i> .....	13
<i>AMPLIFIER BYPASS</i> .....	14
<i>SPEAKERS</i> .....	14

## Installation

<i>PREPARATION</i> .....	15
<i>ADDRESSING</i> .....	15
<i>INSTALL THE SYSTEM HARDWARE</i> .....	19
<i>INSTALL THE BUS CABLES</i> .....	20
<i>CHECK YOUR WORK TO THIS POINT</i> .....	26
<i>INSTALLING A CONTROL PANEL</i> .....	28
<i>CONNECT ACCESSORIES TO THE 980 SYSTEM MODULE</i> .....	31
<i>TESTING NETWORK FUNCTION</i> .....	32
<i>COMPONENT HOOKUP</i> .....	34
<i>DEMONSTRATION FEATURES</i> .....	38

## Reference

<i>APPENDIX A: SAMPLE SYSTEMS</i> .....	40
<i>APPENDIX B: PRODUCT CONNECTION DIAGRAMS</i> .....	45
<i>ACCESS WARRANTY</i> .....	52
<i>INDEX</i> .....	53

# Orientation

## INTRODUCTION

The AccessEZ™ series of demonstration system modules provides a plug-in solution for car audio, hi-fi, and video switching systems in retail display environments. This second generation of the highly capable, industry-acclaimed Access™ System modules offers many new features and benefits:

- AccessEZ offers a compact module to fit each kind of product, compared with a patchwork of printed circuit boards.
- Modules are protected by attractive and rugged steel covers.
- Gold jacks and terminals are clearly and specifically labeled.
- Expansion, when needed, is done by directly “docking” modules.
- Simplified module addressing.
- New audio switching capabilities include Digital (coax) connections and Optical adapters for Toslink® inputs and outputs.
- Master volume controls offer level presets.
- Touchscreen and Graphical control panels invite user interaction.
- Single product group control panel for sub rooms, speaker displays, or any product category.

All these new AccessEZ features are added to the existing capabilities of the Access System which include:

- Your choice of button-per-product, central control panel/computer touchscreen, IR remote, or any combination of user interface.
- Sophisticated SilenTouch™ interval muting for quiet switching.
- Capacity for hundreds of products.
- Comprehensive control panels with automated demonstration features.
- Single button recall of up to 99 stored system configurations.

All of these features make it EZ to design the demonstration system that fits your specific merchandising needs. Your Account Manager and our Application Engineering staff can assist you in selecting and configuring the appropriate AccessEZ modules to build the ideal system for you.

This manual is provided as a framework to help you successfully install your Access System, test its operation, and then use the system to demonstrate and sell your merchandise. This manual covers the proper installation of the switching system hardware only (if your system includes a 902, 903, or 906 Control Panel, or AccessPC touchscreen interface, please refer to the separate User Guide provided with your control panel for operation instructions).

**Please read and follow these instructions carefully.** If you have any difficulties during the installation, don't hesitate to call us for assistance! We are always pleased to receive customer calls. We're open Monday through Friday from 8:30 AM until 5:00 PM, Eastern Time. Also check our website for diagrams and tips: <http://www.audioauthority.com>.

## What is the Access™ System?

The Access™ System consists of a variety of intelligent switching modules. These modules communicate with each other via the “system bus,” allowing you to construct the exact demonstration system configuration you desire from the sources, processors/equalizers, amplifiers, speakers, and subwoofers in your display. The switching modules are located near the actual products on display creating a “distributed switching network.” The products are connected to the modules rather than being wired to one central point. Selected product signals are then sent across the network through “buses” that interconnect the modules. A simplified view is shown below.

Figure 1.

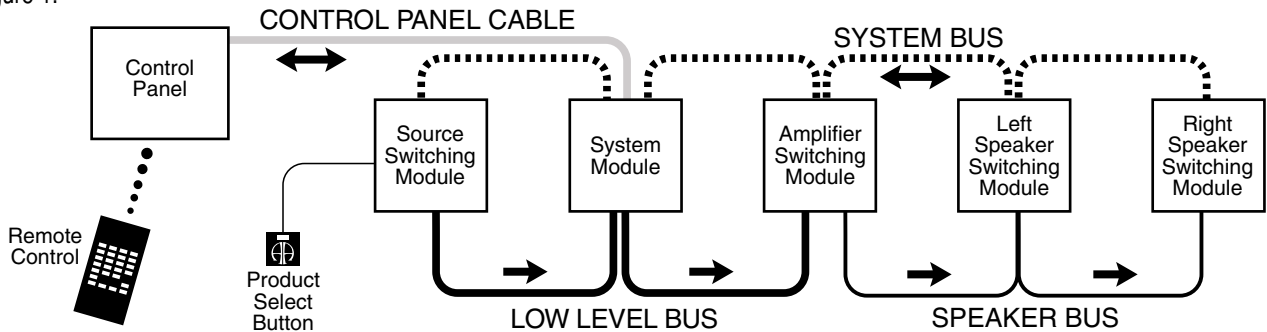

## DEFINITION OF TERMS

To successfully install your new *Access Demonstration Network*, you should familiarize yourself with the following terms:

### Address

A number that pinpoints the identity and location of a switch module within a system. The installer sets numeric switches like the ones in Figure 2 for each module which provides a unique address in the proper sequence for each component connected to the system.

### AutoDamping™

When merchandising many pairs of different speakers in a showroom, the drivers of the unselected speaker pairs become passive radiators when the currently active speaker pair is playing, absorbing much of the sound coming from the speakers being played. AutoDamping™ is a circuit in the Model 932 that electrically disconnects (shorts) speakers not being played, thereby automatically damping them as passive radiators and improving sound quality in the showroom.

### Bus

A Bus is a pathway for signals to travel from module to module; a cable connecting modules. There are three types of buses found in most *AccessEZ* Systems:

- **System Bus** A four wire harness (red, black, yellow, blue) connected to every *AccessEZ* module. The System Bus carries the signals that control the selection of the components and perform various housekeeping functions among the modules in the system.
- **Speaker Bus** (or **High Level Bus**) A four wire harness (green, white, brown, gray) that carries speaker-level signals from source and/or amplifier modules to speaker modules.
- **Low-level Bus** A signal bus using RCA patch cables to carry low-level audio signals between source modules and equalizer or amplifier modules.

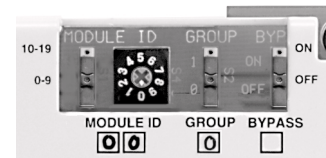

Figure 2. This example shows an address setting of 0/00. Typically this would represent the first module (components 1 through 4) in the Source Product Group.

<b>Bypass</b>	A way to hear a system without a particular in-line component (EQ, Crossover, Amplifier, etc.). For example, when you wish to hear a system without the processor, the system can route the signal past the processor group and directly to the amplifiers. In this example, Position #4 on the last module in the Processor Product Group is used as the bypass location. When this position is selected, or the Product Group is deselected, the audio signal continues through the bypassed group to the next Product Group. To activate bypass, turn ON the Bypass switch only on the last module in the group.
<b>Control Panel</b>	Control Panels, like the 902, 903, 906 or AccessPC Touchscreen, add central control and display capabilities to a system. Any control panel can operate hand-in-hand with product select buttons.
<b>Module</b>	A basic component of the AccessEZ™ System. There are five types of modules normally found in car audio applications: <ul style="list-style-type: none"> <li>• <b>Switching Modules</b> select and connect products for demonstration and communicate with other system components through the System Bus. Examples are Models 910D, 922, 932, 942 and 958.</li> <li>• <b>Expander Modules</b> add channel capacity to switching modules. Examples are Models 920X and 940X.</li> <li>• <b>System Modules</b> perform basic control, interface and housekeeping functions within the system. Examples include Models 980 and 988.</li> <li>• <b>DC Power Modules</b> distribute DC power to sources, EQs, and amps. Examples include Models 915X and 916X.</li> <li>• <b>Signal Distribution Modules</b>, such as the 985EZ and 975, distribute audio and/or video signals to output devices such as Video monitors.</li> </ul>
<b>Position</b>	The numbered point of connection (1-4 for electronics, or 1-8 for speakers) of a product to a switching or expander module. The product select button (PSB) must be connected to the corresponding position on the module. For example, if a component is connected to position 3, its product select button must be connected to PSB position 3. When a “bypass” is required, always use the fourth position (see “bypass”). Control Panels select positions through the System Bus, and are not connected to individual positions.
<b>Product Group</b>	A group of functionally similar products, such as sources, amplifiers, subwoofers, etc. product group also refers to the windows to the right on 902/903 control panels.
<b>Product Select Button (PSB)</b>	A push-button mounted at, or near the product location. Pushing this button selects the product for demonstration and lights an LED to confirm the selection.
<b>System</b>	1. A network of switching modules interconnected by buses where a control panel and/or PSBs are employed to select and thereby interconnect specific components for demonstration. 2. A configuration of audio products or components playing together which can be stored in control panel memory and A/B compared with other “systems.”
<b>SilenTouch™</b>	SilenTouch mutes the sound for a brief period during the switching process to eliminate transient noises while changing from one product to the next.
<b>TheftAlert™</b>	A special circuit that senses ground continuity of the products connected to the switching modules. If an alarm device is connected to the system, it will sound if a product is disconnected from the system without authorization. <i>TheftAlert</i> is an optional feature available through your Audio Authority® Account Manager. <i>TheftAlert</i> may also be added after your initial purchase. A special transformer is required for the feature to work and is provided per your request. You then will need to install it in the proper position on the switch modules.

# HOW THE ACCESS™ SYSTEM WORKS

When a product is selected for demonstration, signals are sent through a network of buses between switching modules to activate that particular product position.

## Selecting Products in the Access System

Products can be selected in a system in different ways that can all be combined into a single system, if desired. You may select products in the following ways:

- By pressing a Product Select Button (PSB) connected to a switching module. This allows the user to build different systems of product configurations manually.
- By using a control panel, if the system is so equipped. Control panel use is covered in detail in a separate manual that accompanies each control panel.
- By issuing commands with the Model 905 IR Remote Control, which is included with the 902 Control Panel and available with the 903. One 905 remote is recommended per salesperson.
- By using a computer touchscreen with AccessPC or custom software configured to enable product selections and other control functions.
- A combination of these methods.

## Buses

Signals are passed between modules by “buses,” which are nothing more than cables that go from module to module to module, connecting them into functional groups within the system’s architecture.

The System Bus connects all switching and system modules, allowing them to send messages to each other, controlled by the addresses that are set by the installer. These signals instruct the modules to select the inputs/outputs of a particular unit, such as a head unit or amplifier. Expander modules are not connected directly to the System Bus. Each expander receives its instruction from the main switch module to which it is attached.

Signal Buses carry audio signals, either low-level (source low-level output, for example) or high-level signals (amplifier output).

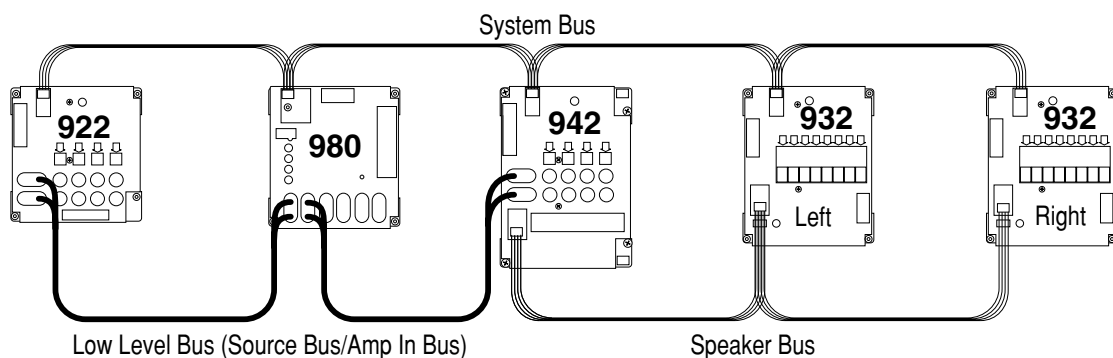

Figure 3. Basic bus examples in a simple demonstration system.

# ACCESS SYSTEM COMPONENTS

If you have already planned your system with the assistance of your account manager, you may wish to skip directly to the Installation section. If you do not have a complete plan for your system, get help from your Audio Authority® Account Manager by calling 800-322-8346.

## Access™ User Interfaces

### Control Panels

#### 902 Full-Featured Control Panel

Includes one 987 Equal Volume Comparison (EVC) module, one microphone with 25' cord, and one 905 IR Remote Control. Because the remote control serves such an essential function in a demonstration, one remote control is recommended for each sales person.

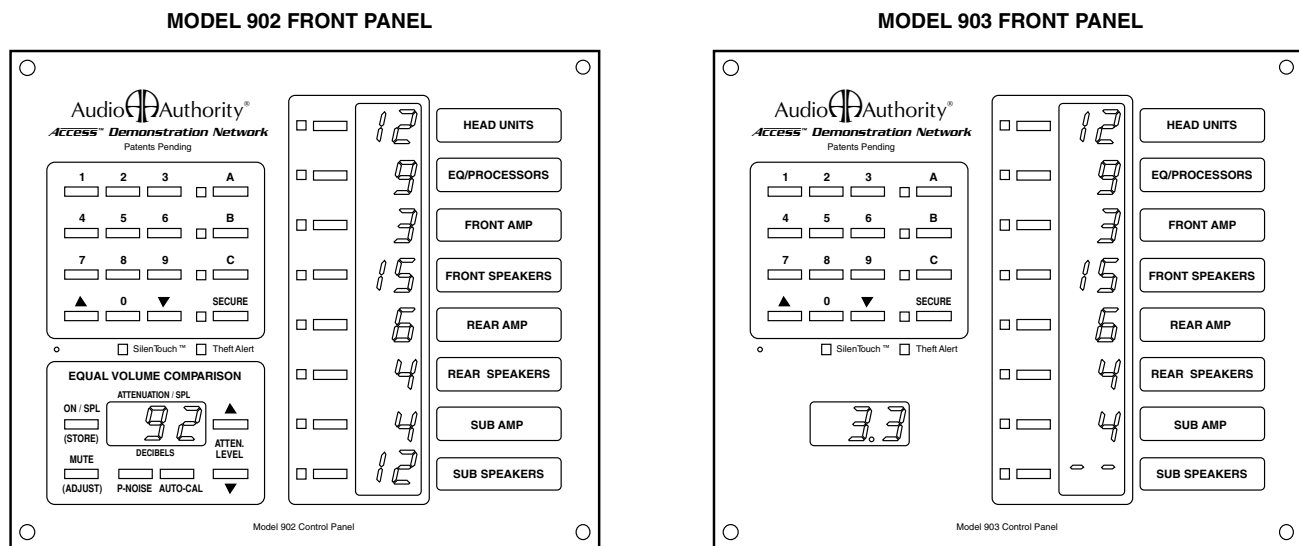

Figure 4. The 903 performs all the functions of the 902 except EVC and SPL AutoLimiting™, and the IR remote is optional.

#### 902 Features include:

- Displays selected products, even when they are selected using Product Select Buttons or by remote control. Displays diagnostic information for troubleshooting the system.
- Removable Product Group insert labels can be changed to indicate the functions of the LED displays. An extensive set of labels is included with the control panel.
- Amplifiers can be connected to more than one Product Group allowing one amplifier to be demonstrated independently as a front, rear, or sub amp (amp sharing).
- If not assigned as an active Product Group, the control panel's last Product Group can store up to 99 pre-configured systems for immediate recall.
- Speakers with varying input sensitivities can be equalized to play at matched volumes by attenuating the output level of the source. AutoCal™ program can run automatically or calibration values can be directly written into the system's memory.
- Optional TheftAlert™ circuit can be armed to sound an alarm should products on display be disconnected without authorization.

- The control panel or any specific Product Group can be “locked out” from unauthorized user input.
- Auto SPL controls the maximum volume level of the currently selected system. The maximum is 120 dB.

### **903 Control Panel**

Similar to the 902 Control Panel, but does not include the 987 EVC module, so Equal Volume Comparison and Auto SPL are not available. The 905 IR Remote will operate the 903 Control Panel but is not included, and must be purchased separately. All other functions of the 902 are inherent with the 903.

### **904 Product Group Expander for Control Panel**

Adds eight additional Product Groups to your control panel. Up to 32 unique Product Groups can exist in an Access™ System.

### **904V Product Group Expander and Volume Control**

Adds four additional product groups to your control panel and provides a master volume control.

### **905 IR Remote**

Full function Infrared Remote Control for 902 and 903 Control Panels.

### **906 Control Panel**

Perfect for single product group displays such as subwoofer rooms or speaker walls, the 906 Control Panel selects products using a rotary encoder knob, and displays the selected product number in the LCD window. Use the Select Previous button to make instantaneous comparisons between products.

### **988CP0 Volume Control Panel**

Provides master volume for *Access* demonstration systems.

### **Product Select Buttons and Indicators**

Various button styles, sizes and colors are available. All have integrated LEDs to indicate when the product is selected. Product indicators are simply LEDs mounted by each product showing which products are playing.

## **Switching Modules**

### **910D Head Unit Selector**

Controls outputs from 4 source units for 4-channel high-level, 2-channel low-level operation. Provides DC power connection for each source. Module can be split in two for greater placement flexibility using a Model 998 Extension Cable. Also features an expander port for adding additional channels.

### **922 Low-Level Selector**

Controls a pair of 2-channel low-level signals routed to or from 4 low-level products such as low-level sources.

### **932 Speaker Selector**

Accommodates 8 left OR 8 right speakers. Two 932s are required for 8 stereo pairs. Non-selected speakers are shorted to ground to reduce the sound absorption of unselected speakers in the display.

### **940EZ High-Level Selector**

Controls two channel high-level signals routed to or from four high-level products. Controls two channels of four products (e.g., high-level sources). Use Model 932 for applications where AutoDamping™ is desired.

### **942 2-Channel Amplifier Selector**

Switches the low-level inputs and high-level outputs of four 2-channel amplifiers.

### **958 EQ or Crossover Selector**

Controls low-level inputs and six channels of low-level outputs from four crossovers or equalizers.

## **System Module**

### **980EZ**

Provides the central point of control for DC power, SilenTouch™, 902/903 Control Panel, TheftAlert™ output, and so forth. The 980 is essential for any Access™ System and is typically installed in the low-level signal path just prior to any amplifier inputs.

## **Expander Modules**

### **920X and Low-Level Expansion Module**

The 920X adds a pair of low-level channels to any switching module.

### **940X High-Level Expander Module**

Adds a pair of high-level channels to any switching module.

## **System Specific Components**

### **970 RS232 Serial Interface/PC Interface**

Connects the Access system to a PC for computer control (Touchscreen, etc.).

### **971 Infrared Control Module**

Customized to send IR commands to infrared audio and video components.

### **977 Digital Audio Adapters**

977R converts optical digital audio signals to coax, and 977T converts coax digital audio signals to optical.

### **975 FM Distribution Amplifier**

12-volt powered FM antenna booster drives all the radio antenna inputs and has direct input for one or more RF output CD changers. Use with distribution components in Kit 16 or Kit 17. Kit 16 provides 4-way taps and cables for FM distribution to sixteen head units. Kit 17 contains one 4-way tap and cables for four head units.

### **9A80 Crossover**

A simple crossover which can be hidden inside the fixture, allowing two-channel low-level signal from the headunit to be split for the demonstration of front speakers, rear speakers, and subwoofers.

### **981 DC Eliminator**

Small, in-line, low-level device that eliminates DC that can be present in the low-level outputs of some head units and crossovers found on the market. One required per offending product.

**982A Low-Level Isolator**

Small in-line, low-level device that eliminates ground loops inherent in car audio displays. One required per amplifier group (982A is not recommended with subwoofer groups).

**983 Four-Channel *AutoMatch* Module**

Device used to protect high-level in/out products on display that have different ground schemes. Device will protect products from harm when a floating ground source is selected to play with an amplifier. If needed, only one unit is required per display when demonstrating high-level head units in combination with power amps.

**985EZ A/V Distribution Amplifier**

Distributes component video signal to up to 8 video monitors.

**987 EVC Audio Level Module**

Adds 4 channels of Equal Volume Comparison and SPL *AutoLimiting* to the 902 Control Panel (one 987 is shipped with each 902).

**990 External Infrared Receiver**

Ceiling mount, omnidirectional IR Receiver used to extend the 905 Remote Transmitter's range for greater line-of-sight distances with the 902 or 903.

**993 Amp Sharing Adapter**

Allows easy hookup for one amplifier to be selected for any of three positions (e.g., Front, Rear or Sub).

**DC Distribution Modules****915X DC Power Adapter**

DC expander Module that provides connections to DC power source for 4 Equalizers, Crossovers, or CD Changers. Includes resettable 10 amp circuit breaker. Use with Model 922 or Model 958.

**916X DC Power Adapter**

DC expander Module that provides connections to DC power source for 4 car audio amplifiers. Uses resettable 10 amp circuit breaker for ignition circuit and 40 amp resettable circuit breaker for circuit from battery terminals. Use with Model 942. The 916X also provides the DC connection points for 980EZ, 910D and 915X modules.

# CHOOSING THE CORRECT SWITCHING MODULES

The Access™ System is very versatile and can be installed and wired in many different ways, including the wrong way. Your Account Manager can help you choose the modules that will best suit your needs. If at any time you wish to change your merchandising approach, Access can be rewired and additional modules can be installed to accommodate a different configuration.

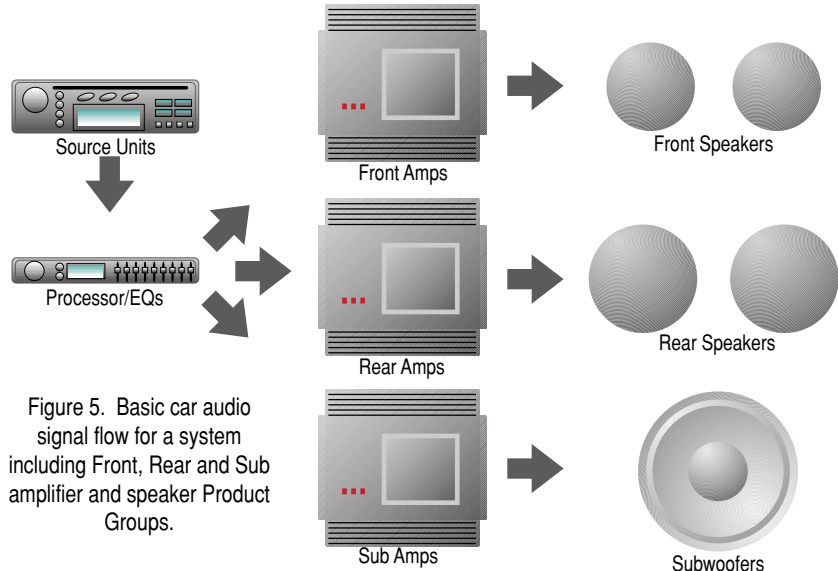

Figure 5. Basic car audio signal flow for a system including Front, Rear and Sub amplifier and speaker Product Groups.

## Product Groups

When planning the installation, try to think of the components you wish to display as belonging to a particular family or GROUP, and where those components might reside in the signal path, for a typical vehicle installation.

## Head Units

The Model 910 is a good choice for almost every type of head unit, from simple 2-channel powered tape/tuner units with only high-level outputs, to CD/tuner units that have low-level outputs (preamp) for rear channels and high-level outputs (speaker-level) for front channels. Both of these varieties belong to the same source family or Product Group and may be switched with the Model 910D (see Figure 6).

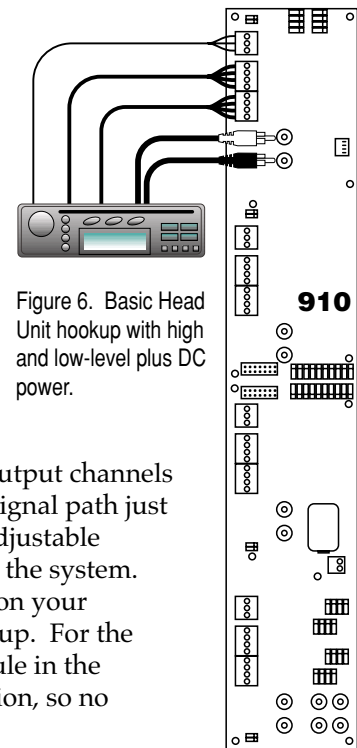

Figure 6. Basic Head Unit hookup with high and low-level plus DC power.

## Processors and Equalizers

The next logical Product Group in the signal path may be Processor / EQs / Crossovers. Generally, these devices have 2-channel (stereo) low-level inputs that are processed through a dividing network to derive multiple output channels (e.g. 2 in x 6 out; see Figure 7). Products in this group are usually wired in the signal path just prior to the amplifier(s) input. Most of these processors have a wide range of adjustable controls that, when over-adjusted, can interject noise (distortion, hum, etc.) into the system. Check the gain setting controls, crossover frequency, and other control settings on your products often. Powered Equalizers would not be included in this Product Group. For the bypass option, remember to leave the fourth position open on the last 958 module in the Processor / EQ Product Group. That position is reserved for the bypass connection, so no processor or EQ can be connected (see pp. 6, 40).

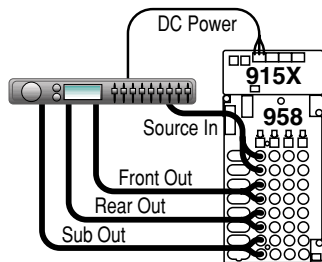

Figure 7. Basic Processor/EQ hookup for low-level inputs and outputs with DC power.

You may not wish to buy the extra switching modules to create a separate Product Group for Processor / EQs, especially if you only carry one or two models of crossovers or passive EQs. However, if you want more than one amp to play at any given time, there should be at least one device (a crossover or processor) in the signal path that can accept a 2-channel low-level input from a source, and deliver front, rear and sub low-level outputs to amplifiers. Many retailers use a single dedicated crossover, buried inside the display, to derive multiple output signals for multiple amp inputs. This may be the simplest solution for your display (see Figure 8). Our Model 9A80 Crossover was designed just for this purpose. Call your Audio Authority Account Manager for details (800/322-8346).

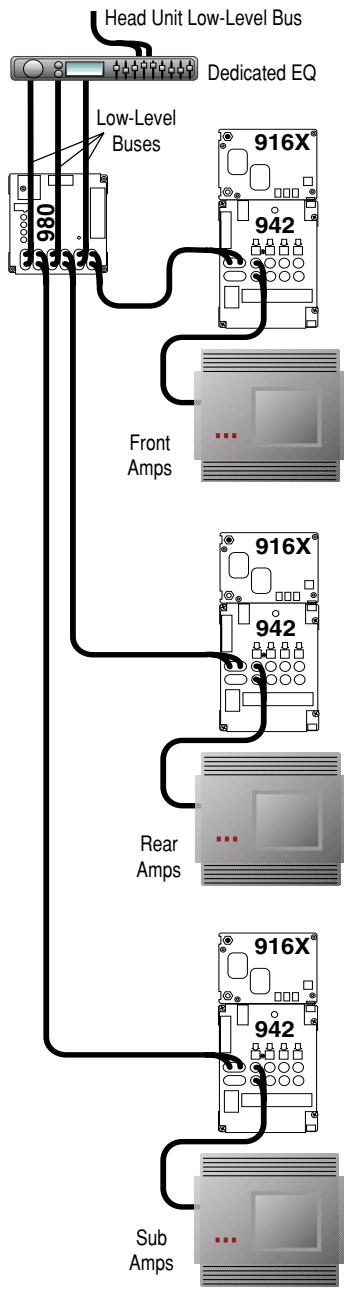

Figure 8. Dedicated EQ and Front/Rear/Sub Amp Groups.

**Amplifier Product Groups**

The low-level outputs of products in the Processor/EQ/Crossover group are connected to the next logical component in the signal path, the Amplifier Product Group. Generally, amplifiers come in two different varieties; those that have low-level and high-level inputs and those that only have high-level inputs, normally called “boosters.” These two types of amps require different switching modules and belong in different Product Groups. If there are no booster-amps in your display, then you probably want to divide the amplifiers you wish to display into Front-channel amps, Rear-channel amps, and Subwoofer amps (see example in Figure 8).

Many of today’s amps have multiple inputs and outputs such as 4-channel amplifiers with Front Left/Right-INs/OUTs and Rear Left/Right-INs/OUTs. There are 6-channel amplifiers, most with their own internal crossovers, and amplifiers that can be specially configured, depending on how you hook them up (e.g. Front L/R Stereo IN/OUT, Rear bridged in mono for Subs).

When planning for demonstrating these multichannel amps, you will need to support each L/R input to the amp, and each L/R output from the amp.

So, a 4-channel amp could be used as shown in Figure 9. The Front L/R Input signal would come from the Processor/EQ Product Group to the Front amplifier Product Group’s Model 942 Amplifier Selector through the Front Low-Level Bus. The amplifier in position #1 receives the front input L/R signal through the 942 in the Front Amp Product Group. The Sub input signal in this example passes through position #1 on the 942 Amp Selector for the Sub Amp Product Group. The High-Level Bus then passes the signals on to the Front and Sub speaker groups.

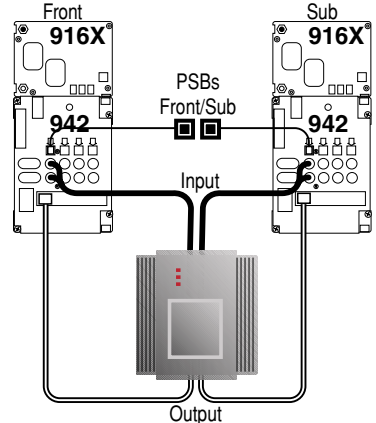

Figure 9. 4-channel amplifier switching (Front/Rear or Front/Sub).

**Amp Sharing**

It is sometimes desirable to have 2-channel or 4-channel amplifiers available to play in more than one

Product Group. For example, you may wish to show the same amplifier driving a Front, Rear, or Sub speaker group. This method of demonstration lowers your display inventory investment and conserves space.

The Access™ System allows the user to share an amp in different Product Groups. To achieve “Amp Sharing”, one must use a Model 942 for each Product Group that the shared amp will appear in. Also, the amp must receive an input signal from the processor’s output for each source or source unit group (see Figure 10). There are several ways to set up amp sharing systems, so call Audio Authority at 800-322-8346 with questions.

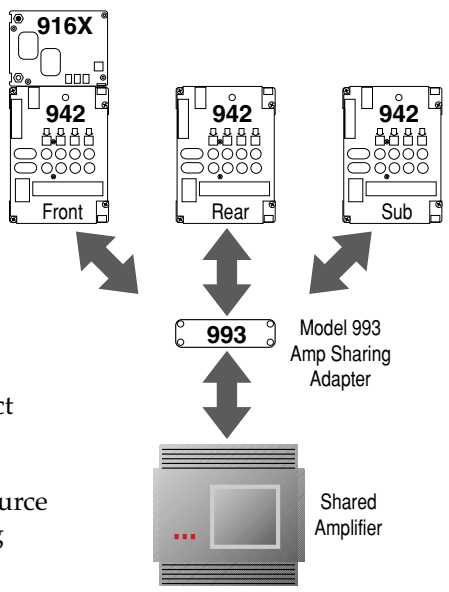

Figure 10. One shared amp may be selected for front rear or sub positions (see Appx. B p. 48).

## Ampifier Bypass

The source signal is supplied when no products in an amp group are selected. For the bypass option, remember to leave the fourth position open on the last 942 module in each Amp Product Group. That position is reserved for the bypass connection, so no amp can be connected there (see pp. 6, 40).

There are many other hookup and demonstration possibilities for amplifiers, many of which are shown in this manual. Please call us at 800-322-8346 if you have questions about the type of switching modules you need, or with any other questions.

## Speakers

The final component(s) in the signal path are the speakers. Each speaker Product Group is powered by the selected amplifier in its corresponding group. So, front type speakers are powered by front amps, rear type speakers by rear amps, etc. The *Access System's* architecture was designed for a maximum of 16 unique speaker groups, with a capacity within each group for 99 pairs of speakers.

### Possible Speaker/Amplifier Product Groups

Front Speakers	Tweeters
Rear Speakers	Mid Range Speakers
Subwoofers	Subwoofers

Figure 11. Some suggestions for group arrangements. Sixteen unique speaker groups are possible.

Speakers use the special 932 switching module. Each 932 switches eight speakers in one channel (8 left or 8 right speakers) so two Model 932s are required for each eight *pairs* of speakers. The 932's *AutoDamping™* circuit shorts unselected speakers to ground so that they do not resonate sympathetically with the selected speaker pair.

In very small systems, it could be more cost effective to use the Model 940EZ high-level switching module for speakers. Each 940EZ module handles 4 pairs of speakers. Unselected speakers are NOT shorted to ground (*AutoDamping*) when the 940EZ is used, but that usually isn't an issue when there are only a few speaker pairs in the system.

Figure 11. Model 932 Speaker Selectors. This configuration could switch eight speaker pairs.

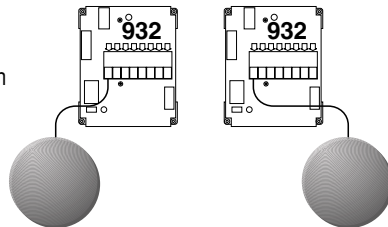
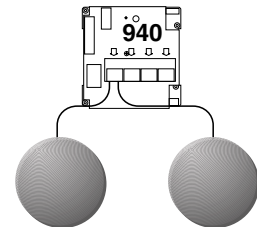

Figure 12. Model 940EZ. This module could switch four speaker pairs, but does not have the *AutoDamping* Circuit.



# BEGIN INSTALLATION

## 1. Preparation

Follow these steps carefully:

- A. Review the design of the demonstration area.
  - Make sure the display fixture is correct for your installation.
  - Look at the supplied system wiring diagram, or choose one from this manual to serve as an example. Examples are in Appendix A: Sample Systems.
  - Gather the owner's manuals of other products that are part of your system for reference during the installation.
- B. Gather the tools and materials you will need.
 

You will need at least the following:

  - #1 and #2 Phillips screwdriver bits
  - #1 small slotted screwdriver
  - Power screwdriver (especially one with a torque clutch)
  - Wire cutter/stripper
  - Cable ties (4" is good)
  - 7/64" and 3/4" drill bits
  - 7/16" nut driver or open-end wrench
  - flashlight
  - 14 - 18 gauge speaker wire
  - high quality RCA patch cords
- C. Check the contents of the shipping cartons. If your system is not pre-installed, use the packing list and your wiring diagram to identify the system components and determine how each component fits into your wiring plan. Refer to the list of Access™ System Components on page 8 to help identify the various items.

## 2. Address and Other Settings

The Access System is made up of smart modules, able to communicate with each other and a control panel when appropriate. Each "main switching module" (see Figure 14) has a set of rotary switches for assigning its unique ID or "address." There are two parts to the address: the "group" number and the "module ID" number. The group number is the general place a module resides in the system, like a street in a city. The module ID is the unique number assigned to each module like individual house addresses on one street. Therefore, each module ID must be unique within the same product group.

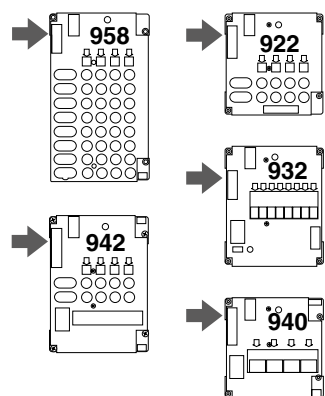

Figure 14. Main Switching Modules and location of Group switch. (Model 910D is always Group 0.)

### A. Number the Product Groups.

First, determine the portion of the address called the group number. A basic group address example is shown below. The column to the right shows the order in which groups appear on the 902 Control Panel. Refer to your system plan to make a chart like the one below. Number each Product Group starting with Head Units (always Group 0).

Electronics Product Group	Speaker Product Group	Group Number	902/903 Control Panel Display
Head Units		0	1
Processor/EQs		2	2
Front Amplifiers	Front Speakers	4	3,4
Rear Amplifiers	Rear Speakers	5	5,6
Sub Amplifiers	Subwoofers	6	7,8

Note that the front amps and speakers have matching group numbers as do the rear amps and speakers. As a rule, related amps and speakers have matching group numbers; this determines how the 902 Control Panel, if used, handles Volume Compensation of the products in these Groups. Figure 15 shows how the 902/903 Control Panel would arrange these product groups on its Product Group display windows.

**B. Determine the Module ID settings.**

Number the modules in each group to put the products in the desired order in the group. Use the following table for the appropriate module ID setting for each module.

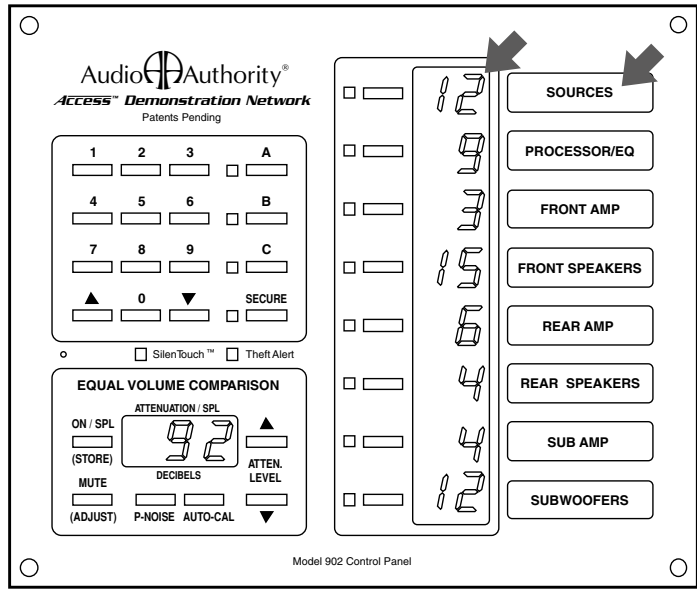

Figure 15. This is how product groups appear on the 902 Control Panel. The display shows which product in each group is selected.

Sources, EQs and Amplifiers			
Switching Modules 910, 922, 958, 942	Addressing Sequence for Product Positions	Set the MODULE ID to:	
		slide switch	rotary switch
1st module:	1 - 4	0 - 9	0
2nd module :	5 - 8	0 - 9	1
etc...	9 - 12	0 - 9	2
	13 - 16	0 - 9	3
	17 - 20	0 - 9	4
	21 - 24	0 - 9	5
	25 - 28	0 - 9	6
	29 - 32	0 - 9	7
	33 - 36	0 - 9	8
	37 - 40	0 - 9	9
	41 - 44	10 - 19	0
	45 - 48	10 - 19	1
	49 - 52	10 - 19	2
	53 - 56	10 - 19	3
	57 - 60	10 - 19	4
	61 - 64	10 - 19	5
	65 - 68	10 - 19	6
	69 - 72	10 - 19	7
	73 - 76	10 - 19	8
	77 - 80	10 - 19	9
	81 - 84	20 - 29*	0
	85 - 88	20 - 29*	1
	89 - 92	20 - 29*	2
	93 - 96	20 - 29*	3
	97 - 99	20 - 29*	4

Speakers		
Addressing Sequence for Product Grps	Set the MODULE ID to:	
	slide switch	rotary switch
1 - 8	0 - 9	0
9 - 16	0 - 9	1
17 - 24	0 - 9	2
25 - 32	0 - 9	3
33 - 40	0 - 9	4
41 - 48	0 - 9	5
49 - 56	0 - 9	6
57 - 64	0 - 9	7
65 - 72	0 - 9	8
73 - 80	0 - 9	9
81 - 88	10 - 19	0
89 - 96	10 - 19	1
97 - 99	10 - 19	2

**How to Use These Tables**

Read across from left to right. For the 1st module's addressing sequence (products one through four) set the MODULE ID to "0 - 9" on the slide switch, and "0" on the rotary switch.

\* Contact the factory if this address is needed.

### C. Set the Address Switches.

Some Group settings are made at the factory, and cannot be changed later. Figure 16 shows the first switch module (Model 910D) in the first Product Group (head units). It has a default address of Group #0 (set at the factory) and the Module ID is set to #00 (this lets the system know this module is connected to the first four products in this product group). The second 910 would be addressed 01, and the third module, 02, etc. Always start with zero, not one, for the first module in any group.

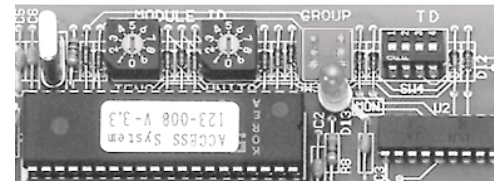

Figure 16. First head unit Module with the address 0/00 (Group/Module ID).

Figure 17 shows the address settings for the fourth module in the Processor/EQ Product Group. The group default is #2 and the address is set to #03.

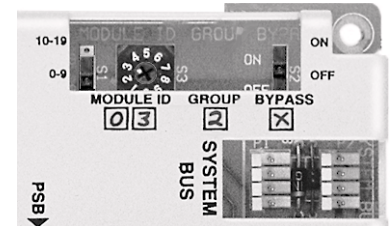

Figure 17. This Model 958 would be the fourth and last module in group 2 (Processor/EQs), because bypass is ON.

### D. Set the Programming Switches.

#### Programming Switch Settings “S M B T D.”

Models 910, 940EZ and 942 have a DIP switch array with small rocker switches labeled S M B T D (Model 910 has T and D only). The slide switches are set to “Off” at the factory. The switches are defined as:

<b>S</b>	<b>M</b>	<b>B</b>	<b>T</b>	<b>D</b>
Single Stereo	Multi- Channel	Bypass	Time	Delay

“D” turns on the DC Power Delay feature and works with the Power Mode switch setting on the 980 module. Use the following chart to determine switch settings. Set the 980’s “Power Mode” switch and each main module’s “D” and “T” switch using the chart below.

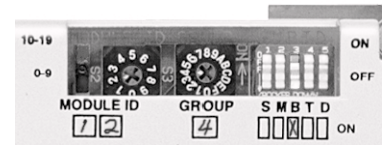

Figure 18. The thirteenth (and last) module in Group 4 (Front Amps). Bypass is ON (“B” in programming switch array SMBTD).

<i>Mode</i>	<i>Effect on Product Groups</i>	<i>Power Mode Switch on 980</i>	<i>Delay or “D” Switch on Main Modules</i>
Power Conserve	1 unit ON; delayed turn-on	ON	ON
Smart Power	Up to 3 units ON; delayed turn-on	OFF	ON
Continuous Power	All units ON; no turn-on delay	OFF	OFF

“T” sets the amount of time delay to allow for product turn-on, if “D” is ON.

“T” - OFF = 3/4 second delay for head units and low power amps.

“T” - ON = 3 second delay for high power amps using switching power supplies.

The “T” switch should be OFF (3/4 second delay) for 910 modules, and ON for 942 modules (3 second turn-on delay for large power amps).

Also, see “Choosing the Power Mode for Your System” on page 24 for more detailed information on the three different Power Mode settings available for your Access™ System.

“B” should be set to “OFF” unless you wish to BYPASS the product group associated with the module. The bypass module is always the last module in the product group to be bypassed (only the bypass module should have the “B” switch turned ON). A product group will be bypassed when all products in that group are unselected. Bypass is commonly used in systems where there are both low-level and high-level output signals from head units (see Appx A, page 40 for a hookup diagram).

“M” has special functions for multi-channel amps and should be set to OFF. Call the factory for details.

“S” is related to “M” and should remain OFF in most cases.

### Set the Left-Right Switch.

Set the 932 Left-Right switch to indicate its position on the right or left side of the speaker portion of your display. 932s are the only modules addressed identically, but the Left-Right switch lets the control panel tell them apart. Set the switch to RIGHT if only one channel (a single 932) is used, as in the case of mono subwoofers.

### Set the Address Switches.

Set and recheck all the address switch settings. Setting the address switches is very important. All functions of the Access™ System depend on correct addressing of the switch modules. Please take the time to double check the labels and subsequent module addresses that you may have set.

### Timeout Minutes and Model 988.

Model 988 (if included in your system) can monitor system activity and restore system volume to a standby level during idle periods. This time period is called “Timeout” and is counted from the last Master Volume control change or Access™ System command such as product selection. Set the 988 “Timeout” DIP switches to total the desired timeout period. For example, if you turn on switches 1 and 2, your system will timeout after 3 minutes. If you do not wish to use the Timeout feature, leave the three Timeout switches turned OFF.

### SilenTouch™ and Model 988.

The Model 988 can administer SilenTouch™ in systems with no 980 module. If both modules are present in a system, turn the 988’s SilenTouch switch OFF (the bottom switch on the 4-switch array).

### Speaker Limit.

The Access System is designed to allow multi-channel amps to play a set of car speakers by separating them into product groups. One amplifier plays two Fronts, two Rears, and two Subwoofers. Additionally, Access allows a default of two speaker pairs to play at once in the same Product Group (e.g. two pairs in the Front Speaker Product Group). Some stereo amp manufacturers do not recommend playing more than one pair of speakers at a time. If customers will have access to your display, consider using the lowest Speaker Limit recommended for any amplifiers you are demonstrating. You may set the Speaker Limit to 1, 3 or 4 pairs with the switch array labeled SPEAKER LIMIT on the Model 980 (default is 2 pair). If your system has a Model 988 instead of a Model 980, the speaker limit is set at two.

## E. Fill out the identification boxes.

Fill out the identification boxes printed on the case of main modules to reflect the address and other settings on each module (see Figure 19). This will help with installation and troubleshooting later.

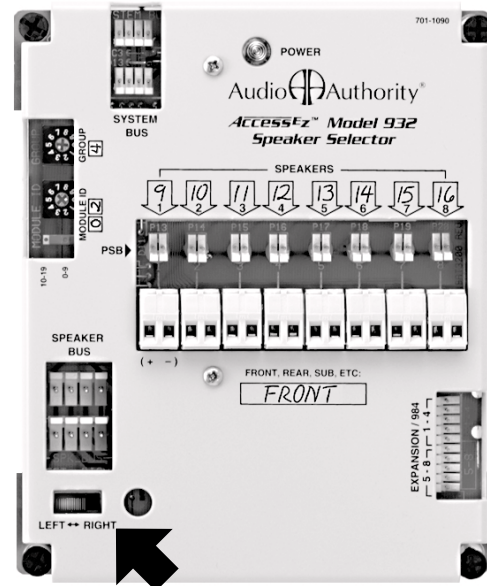

Figure 19. The 932 module serving the left channel of speakers 9-16 (note the filled-in identification boxes).

### 3. Installing the System Hardware

#### A. Designate the Switching Module Locations.

Each switching module controls either 4 or 8 components. Follow your system plan drawing to determine the location of the switching modules in the display fixture. If you are using factory provided bus cables, you may wish to connect all the modules that share the system bus with system bus cable, power up the system on a bench or table, and check the switching modules and control panel logic before actually installing the modules in your fixture.

1. Mark the location of the switching modules and any related expander modules near the center of the products they will serve. Some modules will serve 4 products, others will serve 8 products.
2. Be sure to consider the 2 foot plug spacing if you are using factory pre-made bus cables.

#### B. Determine Other Module Locations.

In the following installation steps, ignore any references to modules that are not part of your system.

1. Position the 980 System Module in the signal path immediately prior to the first module(s) in your Amplifier Product Group(s). This position will allow you to pass signals from the output of your Head Unit or Processor/EQ Product Group to the 980 Module which will then pass the low-level input signals to your Amplifier Product Group(s).
2. If you have “Booster Amps” with high-level inputs in your system, you must use a Model 983 AutoMatch™ Module to protect the components in your display from damage. The 983 is required to “match” floating ground output source units with common ground input amplifier units. The 983 should be located near the 940EZ and 940X switching and expander modules that send and receive signals to and from the booster amps in your display.
3. If your system has a Model 902 Control Panel, you also received a Model 987 EVC Control Module. The 987 Module should be positioned just after the 980 System Module in the Low-Level Bus. When connected, the 980 will receive signals from the 987 Module and send low-level input signals to your Amplifier Product Group(s). There is a hook up diagram on Page 4 of the User’s Guide for the 902 Control Panel.

#### C. Mount the Modules.

1. Mount the main modules first, then plug in and mount signal and DC expander modules in the system. Use the screws provided.
2. Connect an audio signal expander (if any) such as 920X or 940X to its respective main switching module as shown in Figure 20. It is critical that the signal expanders be connected to the header port on the main module labeled “Expansion.” DO NOT plug an audio signal expander module to the header port labeled “DC Expansion.”

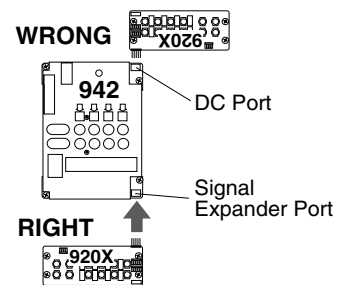

Figure 20. Audio signal expander connection

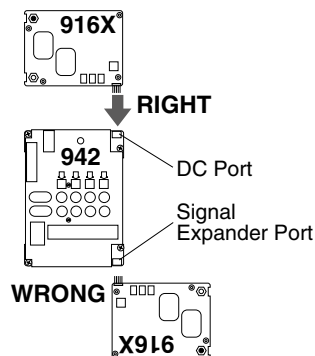

Figure 21. DC Expander connection

3. Connect each 915X and 916X DC Expander Module to its respective main switching module and attach with screws provided. Be certain to connect DC expander modules to the header port on the main module labeled “DC EXPANSION.” DO NOT plug a DC expander module to the header port labeled simply “EXPANSION.”

## 4. Installing the Bus Cables

Pre-assembled bus cables or the raw materials to make the necessary bus cables on the job site were included with your system purchase. Pre-assembled bus cables have connectors every two feet (RCA patch cords are available in lengths from three to twenty feet). If you plan to make your bus cables on the job site, you'll need a special assembly tool available from the factory.

If you are making your own bus cables, be very careful to follow the assembly instructions, especially concerning wire to connector polarity. Incorrect bus fabrication can cause system failure and damage!

Several types of bus cables are available for specific purposes:

Cable Type	Color Code	Pre-assembled Part Number	Cable for Site Assembly	Plug for Site Assembly	Assembly Tool
System Bus	yellow/red/blue/black	802-307	871-055	916-0470	762-011
Speaker Bus	green/white/brown/gray	802-186	871-045	904-172	762-009
Low-level Bus	RCA patch cords	801-018 to 801-023	EX2, EX1	SGRCA	762-006
System extension*	yellow/red/blue/black	802-323	871-055	916-0470	762-011
Speaker extension*	green/white/brown/gray	802-309	871-045	904-172	762-009

\* The System and Speaker Bus extension cables allow you to join remote sections of the Access™ System with the main electronic component section of your display, as in the case of rear speaker towers.

Any RCA patch cords are suitable for the low level bus or component connections; however, we highly recommend that you use our special low-capacitance RCA patch cables for optimum system performance and reliability.

### A. Install the System Bus

The system bus connects only to main switching modules (910, 920, 958, 942, 932, 940), not expanders (920X, 940X, 915X, 916X).

1. Use the pre-assembled system bus cables supplied with your system or install the 4 pin plugs onto the system bus wire using the special tool. If you are making your own system bus, be sure to leave a small amount of slack in the wire between the modules and be very careful to observe correct polarity.

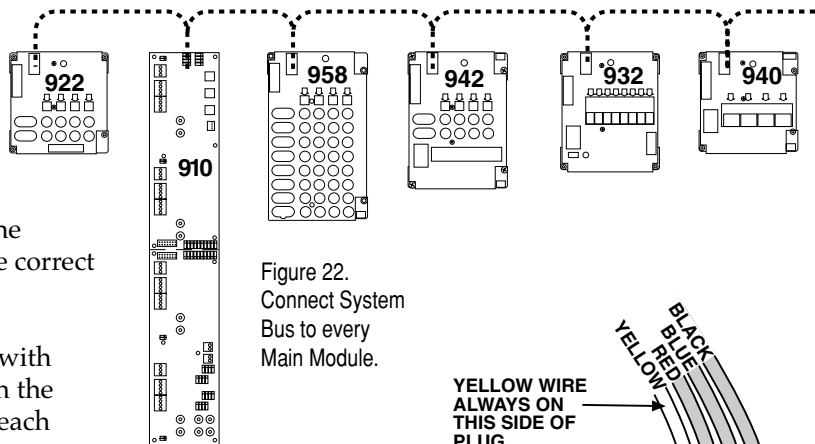

Figure 22. Connect System Bus to every Main Module.

2. Mate one plug of the system bus cable with either of the 4 pin headers marked with the yellow / red / blue / black color code on each switching module.
3. Connect the system bus to all modules having headers marked SYSTEM BUS. The connectors are polarized, so they will only connect in one direction, but always make sure to prevent the possibility of plugging the system bus to the header backwards (see Figure 23).
4. Start at one end of your system and work toward the other end, connecting the system bus to every main module.
5. If you are using Pre-assembled buses, you may use a system bus extension cable for long distances between modules, or carefully splice 18 gauge cable where needed.

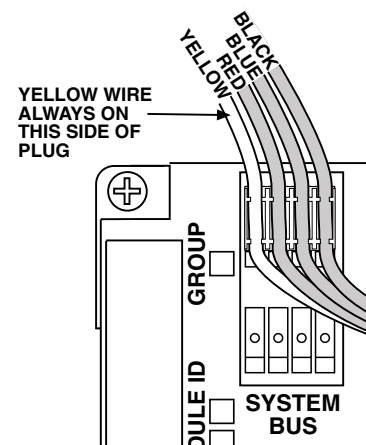

Figure 23. Observe correct System Bus polarity. It is fine to leave one header unused.

- Dual header connections are provided on all modules so you can easily extend a bus cable that is too short, or you can branch off the main run to a remote or side group of modules, if necessary.

Note: Since bus connectors can be both in and out, one header connection may be left open. The remaining connector may be used to create a branch from the bus.

## B. Install Speaker Bus.

The procedure for running the Speaker Bus is very similar to the installation of the System Bus. The speaker bus will be used to send high-level signals from amp outputs to speaker modules in the system. (For very small systems with no amps, the head unit group is connected directly to speaker groups via speaker bus.)

- Connect related modules with a continuous run of bus cable.
  - Start from the module at one end of the group and work toward the other end.
  - Run separate buses for front, rear and sub (or tweeter, mid, and sub).
- Using the a green/white/brown/gray bus cable assembly, plug a connector of the bus into a **SPEAKER BUS** header on each 942 module in the Front Amplifier group. The connectors are polarized, so they will only connect in one direction, but always make sure to prevent the possibility of plugging the system bus to the header backwards (see Figure 24).
  - Using the same bus cable or branching off with a new section of bus cable, continue connecting all 932 modules in the Front Speaker group to the Front Speaker Bus.
  - Connect all remaining Amplifier/Speaker Product Groups in the same way.
  - Extend system or speaker buses, if necessary, using the available extension cable assemblies.

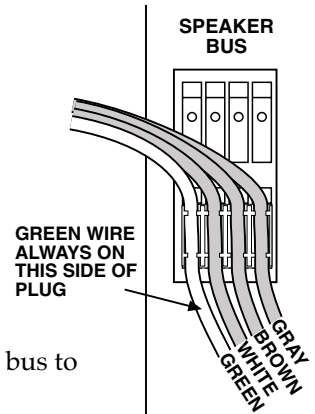

Figure 24.

## C. Low-Level Buses.

The rules are similar to those for installation of the other signal buses:

- Connect modules within a group and to corresponding groups.
- Start from the module at one end of the product group and work toward the module at the other end.
- Low-level cables are quite different from other bus cables. Use only high-quality shielded RCA patch cords, preferably gold-plated, for low-level bus connections. Use Audio Authority® Excellerator Cable and Solderless Gold RCA Connectors for made-to-measure cables of exact length, especially for those runs over 6 feet.

Figure 25. Speaker Bus Example.

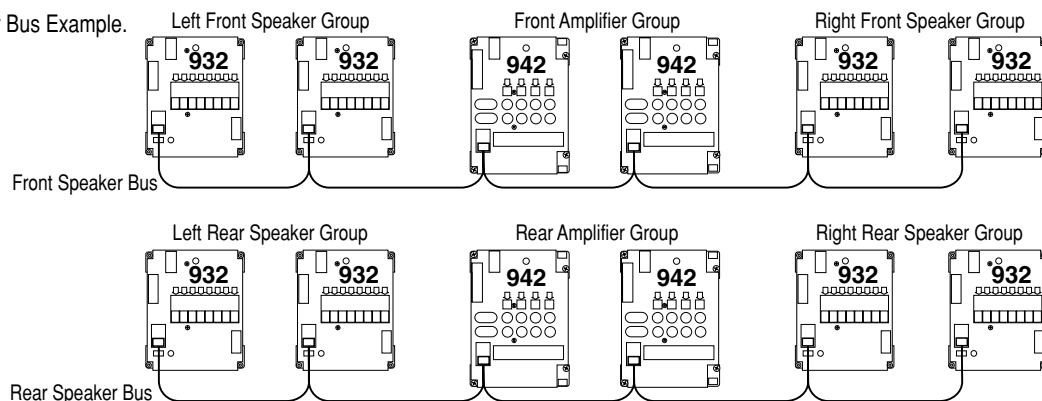

- Using high-quality shielded RCA patch cords, connect the modules with low-level jacks (910, 922, 958, 980 and 942) along with any low-level expander modules (920X).
- Connect all modules serving each pair of low-level channels in a given group, such as source outputs (910 or 922), front amp inputs or rear amp inputs (942).
- Connect a module from each low-level group of modules to a module of the next low-level group in the signal path. Here are two examples:
  - Connect the source output bus to the processor bus input; if using a single dedicated processor to derive additional amplifier product groups, connect the source output bus directly to the input of the dedicated processor.
  - Connect the processor output bus to the 980 System Module input bus; connect the 980's output bus to the amplifier bus input. The 980 has inputs and outputs to feed processor output signals to front, rear, and sub amplifier groups (see Figure 26).

#### D. EQ and Amplifier Bypass.

To demonstrate high powered head units without other in-line products such as processors, equalizers or amplifiers, use Speaker Bus cable to create a front and rear high-level bypass from the Source Product Group directly to the Speaker Product Group (for a hookup diagram, see page 40).

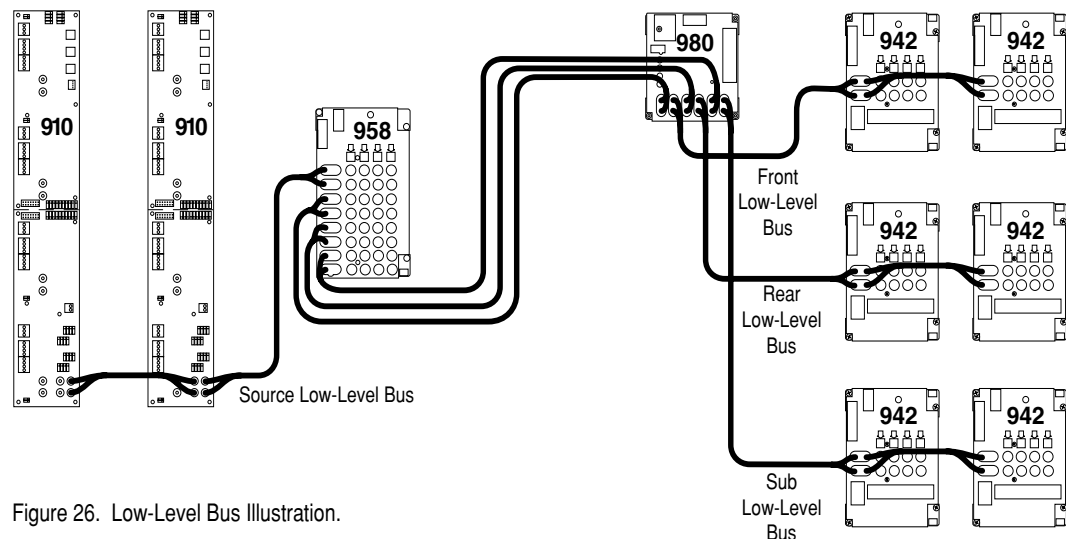

Figure 26. Low-Level Bus Illustration.

- Hook up the Source Group's Front High-Level Bus using a green/white/brown/gray bus cable assembly. Plug a connector of the bus into each header marked FRONT HIGH-LEVEL BUS on 910 modules in the Source group.
- Connect one end of the Front High-Level Bus to the fourth position on the last 942 module in the Front Amplifier Product Group (see Figure 27). Turn on the "B" switch to activate bypass on that module.
- Using a separate green/white/brown/gray bus cable assembly, plug a connector of the bus into each header marked REAR HIGH-LEVEL BUS on 910 modules in the Source group.
- Connect one end of the Rear High-Level Bus to the fourth position on the last 942 module in the Rear Amplifier Product Group. Turn on the "B" switch to activate bypass on that module.

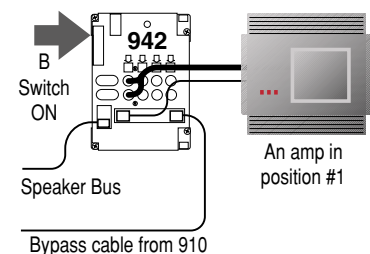

Figure 27. Amplifier Bypass configuration. No amp may be connected to position #4.

To demonstrate amplifiers without inline products such as Processors or EQs, it is necessary to bypass the Processor/EQ Product Group at low-level. Figure 28 shows how to route the signal from the input of the 958 past the display product connections and on to the Amplifier Product Group. The fourth position on the last module is reserved for bypass in Product Groups using a bypass.

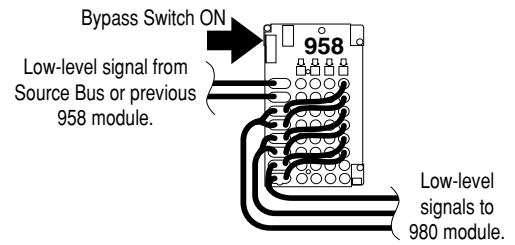

Figure 28. EQ bypass bus wiring on last 958 in the Processor/EQ group. No EQ can be connected to position #4.

### E. Install the DC Power Distribution Cables.

The 915X or 916X DC Expander Modules should already be installed and connected to electronics modules. Use the EZ docking port unless more than one connection is required (e.g., ampsharing) then use the 5 wire expander cable. Check your system plan or use one of the drawings in Appendix A to determine each module's location.

- 915Xs are generally used to power Processor/EQs and CD Changer units. In most systems, head units are powered directly from the 910 Head Unit Switching Module.
- 916Xs are used to distribute DC power to amplifiers and to provide home run DC connection points for 910D and 915X modules.

Run the high current DC bus to all 916X Expander Modules. Any 916X can then provide the connection point for 980EZ, 910D, and 915X modules. See Figure 29 and refer to Appendix A for wiring examples.

1. Use the provided red and black 4 gauge wires with small ring terminals on the ends. Hang on to the other included wire assemblies; they will be used to furnish DC power to your display components later.
2. Start with the 916X expander that is closest to the DC power source (and battery, if one is planned in your system).
3. Connect the red and black 4 gauge wires to the large color-coded red and black, brass terminal posts on the 916X. Connect the red wire to "BAT+" and the black wire to "BAT-" using a 7/16" nut driver or open end wrench. Be sure to tighten the brass nuts snugly so that the ring terminals are well seated on the terminal posts.

Note: While connecting the initial run of red and black wire to the next 916X module, also connect a separate 4 gauge red and black set of wires to the 916X's terminals for final connection to your system's DC power supply or battery.

4. Now, connect the red and black wires to the next 916X in the system, making a "daisy-chain" until the last 916X is connected.
5. Run low-current DC to all 910 Source Modules and 915X Expander Modules.
6. Use the red and black 14 gauge wires provided with the 910. Connect the ring ends to the DC bus terminals of the nearest 916X.

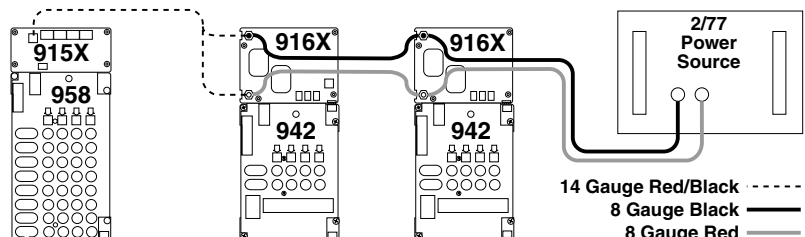

Figure 29. DC trunk lines connect 916X modules to each other and the power source; 915X, 910D, and 980EZ branch from the nearest available 916X.

7. Cut the red and black wires to length, strip the ends and insert them into the terminal block on the 910 module labeled "DC Power Bus." Wire red to "+" and black to "-" and tighten the screws securely.
8. If 915X modules are part of your system, wire them in the same manner as the 910 modules.

Connect the pre-made power cable supplied with the 980 System Module to the terminal posts of a nearby 916X. Tighten all the brass nuts on 916X bus terminals until snug. DO NOT plug the other end of the power cable in to the 980 at this time.

### **Power Supply Ventilation.**

It is very important to provide adequate ventilation for the power supply in your display fixture. A car audio DC power supply generates a lot of heat which must be dissipated. If the power supply will be enclosed inside your display fixture, you must provide an incoming source of cool air and an opening at the top of your display for ventilation of the heated air. If using a Model 277 Hybrid Power Source, follow the provided instructions to properly ventilate the unit.

- A. Make the final connections to prepare your system for initial testing. If your system includes a battery, **DO NOT** install it until all testing is complete.
  1. Connect the red and black battery lead wires to the 916X most convenient to the battery location (do not connect the battery). The lead wires have large ring terminals on one end and small rings on the other. Connect the small ring terminal ends of the red and black leads to terminal posts of the 916X.
  2. Install the power supply, preferably an Audio Authority® Model 2/77 Hybrid™ Power Source in your display fixture. Take the time to read the owner's manual that came with your power supply.

WARNING: Keep all metal tools away from the power supply terminals, and all terminals on 916Xs once the system is connected and powered up.

3. Connect the other end of the red wire from the 916X to the positive (+) terminal of the power supply. Secure the battery connection with a wing-nut and stud furnished with the Model 2/77.
4. Connect the black wire to the (-) power supply terminal in the same fashion.
5. Now, plug the red and black power wire assembly you installed earlier into the 980's power socket.
6. Plug the Model 2/77 or your alternate power supply into a continuous source of 120 volt power.
7. Test your system by turning your power supply ON.
  - A. Each main module has a green LED that should be flashing, like a "heartbeat." If any modules lack a heartbeat, check the system bus connection.
  - B. If using a Model 2/77, turn it on and leave it on 24 hours a day once your installation is complete. When turned on, a green NORMAL OPERATION light will illuminate on the Model 2/77.

### **F. Choosing the Power Mode for Your Display.**

You previously determined the Power Mode setting when you completed the DIP switch settings on the main switching modules and 980 System Module earlier in the installation. Now that you have reached this point, you may wish to reconsider the Power Mode(s) you will use. Read the following information for more detail. There are three different power modes available in the Access™ System to turn ON the components in your display. The Power Mode is determined by using different combinations of switch settings on the 980 and the main modules in your system. The Power Mode setting determines how many components will be powered at any given time and whether or not there is a turn-on delay. You may use more than one power mode within the same system, depending on the "D" switch settings on 910, 958, and 942 modules.

Here are the three different Power Modes:

- **Power Conserve** allows only one component from each electronic group to be ON at any given time. New selections have a turn-on delay of either 3/4 seconds or 3 seconds, depending on how the T switch is set on each main module.
- **Smart Power Mode** allows up to three components in each electronic product group to be on at any given time. When a fourth component in the group is selected, the first selected component in the group powers down, and so on. If there is no new selection activity in the group within 5 minutes, all components in the group power down; then, a new selection cycle begins. There is a turn-on delay for each new selection (no delay for the products recently selected); the length of the delay is determined by the T switch setting on the selected component's main module.
- **Continuous Power Mode** allows all electronic components in the display to be ON and ready for immediate selection with no delay. Since all components are ON it is extremely important to have an adequate source for DC power, for car applications, like the Audio Authority® Model 2/77 Hybrid™ DC Power Source. (In very large displays two 2/77s may be required if Continuous Power Mode is used.) Choose either the Continuous Mode or the Smart Power Mode if you desire instant A/B or A/B/C comparison of components in your display.

Set the 980's "Power Mode" switch and each main module's "D" and "T" switch .

<i>Mode</i>	<i>Effect on Product Groups</i>	<i>Power Mode Switch on 980</i>	<i>Delay or "D" Switch on Main Modules</i>
Power Conserve	1 unit ON; delayed turn-on	ON	ON
Smart Power	Up to 3 units ON; delayed turn-on	OFF	ON
Continuous Power	All units ON; no turn-on delay	OFF	OFF

Remember, T set to OFF = 3/4 second delay for head units, processors or small amps (Models 910, 958)  
T set to ON = 3 second turn-on delay for large power amps (Model 942).

### **G. Setting the Parallel Speaker Limits.**

The Access™ System can be programmed to allow multiple pairs of speakers to play in each Speaker Group at one time from the same amplifier.

When the system is programmed to allow this, you should consider the possible effects on your amplifiers. For example, when 2 pairs of speakers play in parallel in the same group, the load presented to the amplifier is increased in exactly the same manner as connecting the two pairs of speakers directly to the amp's output. The amp now "sees" a lower impedance or higher load and works a little harder, by playing a little louder. If you were to choose two pairs of speakers, both at 4 ohms, connected in parallel, the two pairs would present a 2 ohm load to the amp. If three pairs of 4 ohm speakers were selected, the load impedance could be 1.7 ohms or lower.

Many amps are stable down to a 2 ohm load, however, many are not. We recommend that the programming switches be left at the factory default setting which allows two pairs of speakers in each speaker group to be played simultaneously. Playing 2 pairs of front speakers, 2 pairs of rears, and a pair of subs is a very powerful demonstration.

The *Access System* allows you to program up to 4 pairs of speakers to play in the same product group. However, we strongly encourage you to leave the default setting at 2 pairs per group, unless you're very confident of each and every amp's stability.

Immediately beneath the "Power Mode" switch on the 980 are three additional switches labeled "Speaker Limit." The switches are set to OFF at the factory. To change the factory setting, turn on the limit number switch you want. Leave the other switches OFF.

Example: Turning limit number 3 ON allows three pairs of speakers per group to play simultaneously.

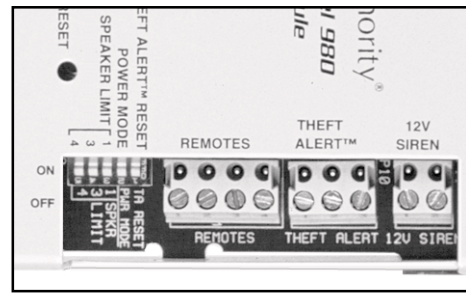

Figure 30. Detail of 980EZ Module showing speaker limit switches.

## H. Install the RF Antenna Distribution System.

If your system plan included provisions for an Antenna Distribution System, or includes RF distribution for CD changers, install the 975 FM Distribution Amp and a KIT17 for each group of four head units.

- A. Unpack items 975 FM Amplifier and KIT17(s). Follow the enclosed instructions completely, making sure that the coax cable used to connect the 4 way taps is not kinked or bent during the hookup process. If you need additional instructions, please contact the factory and ask that we send you our part number 752-139.
- C. Use a 7/16" open-end wrench to tighten all F-connector terminations.
- D. Make certain that the F-to-Motorola cables are not allowed to touch the switching modules. The Motorola plug could cause a short if allowed to touch the modules.
- E. Make sure that you have inserted the proper F-59 Termination Plug in the last 4 way Tap Block's "Out" position (Figure 31).

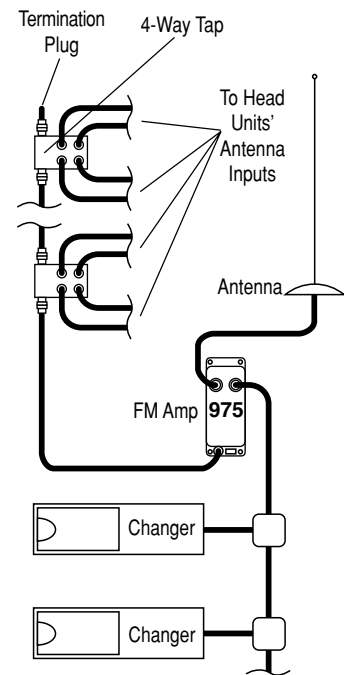

Figure 31.

## Check Your Work to This Point.

Before continuing any further, it would be a good idea to check the following:

1. Check the Group and Module ID settings on all modules against your system plan.
2. Check the Expander modules in the system to insure that audio signal expanders (920X, 940X if any) are connected to the "Expander" header and that the DC expander modules (915X, 916X) are connected to the "DC Expansion" header on their main modules.
3. Check programming switches, especially the following:
  - Bypass switch is ON where a bus has been connected to the 4th product position on the last module in a group that can be bypassed (such as processors, passive EQs, amplifiers, etc.).
  - Left-Right switch set correctly on 932 Speaker Selectors; LEFT for left speakers, RIGHT for right speakers. In special cases, like mono subwoofers, set switch on the single 932 to RIGHT.

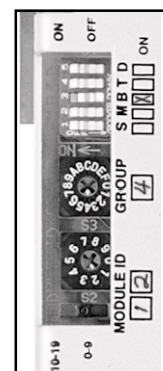

Figure 32.

- If your system is all new, proceed to step 4. If some or all of your system is older (software version earlier than 3.2) the SST jumper switch on the 980 module must be in the FAST pin position (Figure 33). The factory position for the jumper is “NORM.” The SST jumper on the Model 980EZ must be cut and re-soldered to change its position. (The software version you have can be easily identified by the label on the large “chip” on each main switching module; all AccessEZ™ products are version 3.3 or higher).

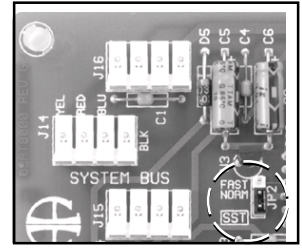

Figure 33. The “SST jumper switch” on the 980A.

#### 4. Check signal bus routing.

- Follow the physical path of signal buses from source group products, through intermediate product groups, out to the speaker groups.
- Be sure to include all product groups in your inspection.
- Include all bypass conditions; check groups that can be bypassed, such as processors and amplifiers. Make sure only the last module in the group (module with the highest Module ID setting) has the “B” or “Bypass” switch in the ON position.

5. Make sure the system bus and speaker bus have solid connections, with the correct polarity (Figure 34). When your system is powered up from a battery or power supply, all the main modules should be blinking, with a “heartbeat.” If one or more modules do not show the blinking LED, check the System Bus connections.

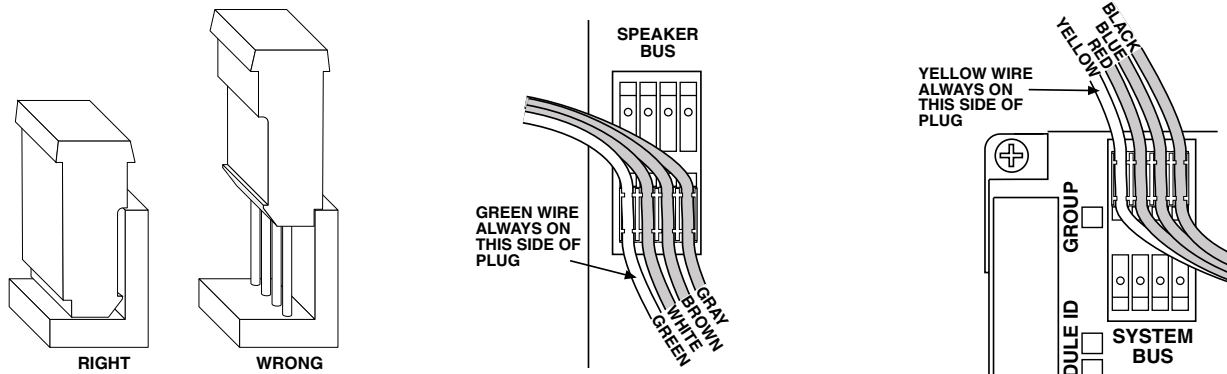

Figure 34. Observe correct polarity for all bus connections.

6. Check the DC bus. If one or more products do not power up, and you are confident of the DC bus connections, check each 910, 915X, and 916X module for a Red, non-blinking LED close to the black plastic or metal circuit breaker on the circuit board. If the Red LED is ON, push the circuit breaker’s RESET button.

# INSTALLING A CONTROL PANEL

Skip this step if you do not have a 902, 903 or 906 Control Panel, or if the display is pre-assembled. If you have a 902 or 903 Control Panel, it is accompanied by a separate User's Guide which you should locate for future reference.

1. Cut an opening for the Control Panel if you wish to flush mount it in your display. You can also use a 989 Enclosure Kit to house your Control Panel which can be shelf-mounted in your display.
  - For the 902 or 903 Control Panels, cut an opening 7" (178 mm) wide by 5-1/8" (130 mm) high.
  - For the 906 or 988CP0 Control Panel, cut an opening 4 -1/16" (105 mm) wide by 5-1/8" (130 mm) high.
  - Use the panel to mark screw hole locations and drill 7/64" (2.5 mm) holes for the screws.
  - Insert the appropriate slide-in Product Group labels provided with your control panel into the product group display windows to identify each component group on the panel. Consult page 6 of your 902/903 User's Guide for more information on Product Group labeling.
2. If you have a 902 Control Panel, locate the 987 EVC Module that came with the 902. You installed the 987 earlier near the 980 System Module (see page 19). Connect the 902 to the 987 using the 10-pin ribbon cable provided. Note: You will still need access to the rear of the 902, so do not mount it permanently yet.
3. Using the 10 foot cables supplied, plug the 902 or 903 into the 980 System Module at the header marked 902/903.
  - The 987 should already have RCA cables connecting it in the signal path out of the 980 that feeds the amplifier input buses.
  - Hang the 902's calibration microphone about 1 foot from the ceiling at the center of the listening area. The mic can be flush-mounted in the ceiling tiles, if desired, but performance may suffer. The mic is an omni-directional electret condenser microphone.

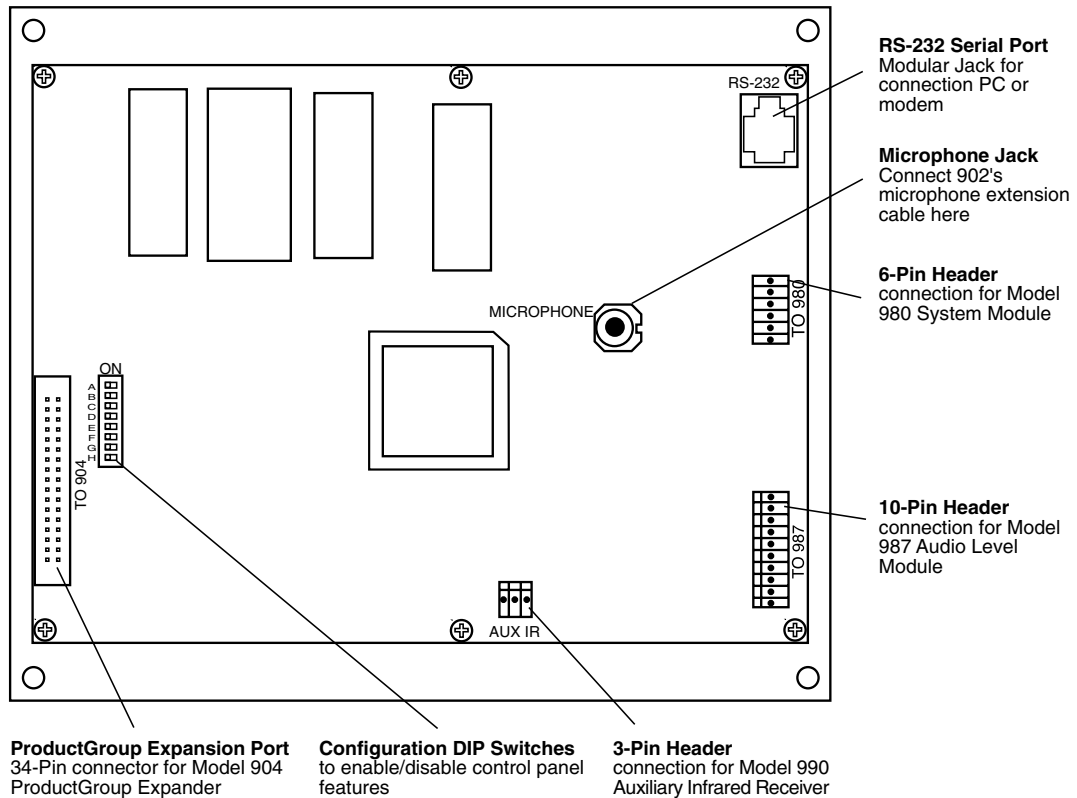

Figure 35. Rear view of the 902 Control Panel.

- Plug the calibration microphone into the Microphone jack located on the rear of the 902, using the extension cable provided, if necessary.
- If your system includes a Model 990 Remote Infrared Receiver, mount the 990 to the ceiling in the display area and connect the 990 to the header on the rear of the 902 labeled "Aux IR."

Note: The 903 Control Panel can also be remotely controlled using a 905 IR Remote. A single 905 remote is packaged with the 902, but must be ordered separately for the 903.

#### 4. Set the Programming Switches on the 902/903.

- Use the following chart to set the 8 programming switches located on the rear of the 902/903 Control Panels (next page).

Switch	Function	Comments
A	Keyboard Click	Turn ON for audible key feedback or "beep"
B	Demo-Mode	Leave OFF. Use only when control panel is not connected to a system as a "Training Mode"
C	Systems Memory	ON makes the last unused Product Group capable of storing and recalling 99 system configurations*
D	Future Use	Spare, leave OFF
E	Previous Selection	OFF = "C" key is third "flash memory" key ON = "C" key is toggle between current selection and previous selection
F	902/903	902 = OFF; 903 = ON
G	Internal IR	Turn OFF when using 990 Remote IR Receiver
H	Auxiliary IR	Turn ON when using 990 Remote IR Receiver

\* If a 904 or 904V Product Group Expander is installed, the last Product Group on the Expander is used for "Systems" instead of the last Product Group on the 902/903 itself.

#### Control Panel Expanders.

All panel openings are 5 $\frac{1}{8}$ " (130 mm) high. Correct cutout widths are shown below. If you have a 904 or 904V Control Panel Expander for use with your 902/903, follow these instructions:

- Cut an opening 11 $\frac{3}{16}$ " (285 mm) wide by 5 $\frac{1}{8}$ " (130 mm) high to accommodate both the 902/903 and the 904 panels.
- Insert the appropriate slide-in Product Group labels provided with your control panel into the product group display windows.
- Connect the 904 ribbon cable to the matching header on the rear of the 902/903 marked "To 904."
- Mount the Expander in the opening together with the 902/903 Control Panel.

Control Panel Cutout Sizes	
Panel Units	Cutout Width
906 or 988CP0	4 $\frac{1}{16}$ " (105 mm)
902 or 903	7" (178 mm)
902/3 + one expander	11 $\frac{3}{16}$ " (285 mm)
902/3 + two expanders	15 $\frac{3}{8}$ " (390 mm)
902/3 + three expanders	19 $\frac{9}{16}$ " (495 mm)

- Mount the control panel(s) using the four black screws provided. Do not overtighten the screws. Too much torque during screw insertion can crack the acrylic panel cover.

### Installing Product Select Buttons and Product Indicators.

Your system plan may specify using product select buttons (PSBs), and product indicators (LEDs) in conjunction with a control panel. Some system users prefer to use PSBs as the only method of product selection and do not have a control panel as part of their demonstration system.

If you have standard square PSBs and/or Product Indicators, install them as follows:

- Determine where each PSB and Indicator will be located. Most users prefer to locate PSBs close to the actual product the PSB will select. PSBs are often placed near product information tags or signs that describe the features and benefits of the products on display. Indicators are also normally placed close to the components to identify the product(s) currently selected.

- For standard square PSBs: drill a small pilot hole in the panel or surface where each PSB or LED will be located. Now, drill a  $\frac{3}{4}$ " (19 mm) hole; be precise, a sloppy hole won't work.
- For LEDs: drill a small pilot hole in the panel or surface where each LED will be located. Now, drill a  $\frac{5}{16}$ " (8 mm) hole; be precise, a sloppy hole won't work.
- Disconnect the cable from the PSB or LED, and take note of the plug polarity. Carefully insert the PSB or LED in the hole and check the fit. Plug in the PSB cable so that the cable exits the plug on top for PSBs as shown in Figure 37. If an LED or PSB does not light up when testing the system later, simply reverse the polarity of the plug.

Note: if there is no space, or there is some other reason that holes cannot be drilled for standard PSBs, consider using our surface mount ZipSwitch PSB.

- Carefully insert the PSB or Indicator in the hole and check the fit. You may wish to leave the PSB or Indicator mounted in the product panel, or install them later after your components have been mounted to their respective product mounting panels.

- Locate the switching module where the component will be connected. Each module has either 4 or 8 two-pin headers above the product connectors numbered from 1 - 4, or 1 - 8. As you install the display products, you will connect the PSBs and Indicators to these headers using the cable assembly supplied with each.

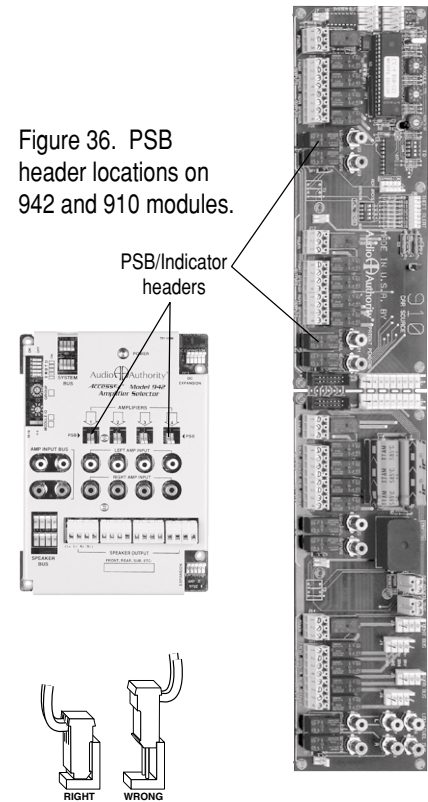

Figure 36. PSB header locations on 942 and 910 modules.

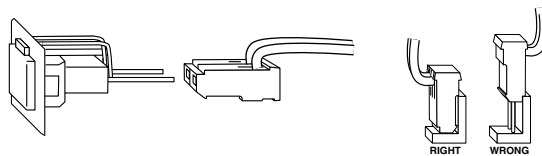

Figure 37. Be careful to maintain PSB cable polarity at both ends.

## 980 System Module Accessories.

In systems without a control panel, it is usually desirable to add “outboard” switches for remote operation of certain 980 system management tools.

### Remote Power Switch.

If your system does not include a Control Panel, you may want to turn the system on and off using a remote key switch or toggle switch.

- Use any SPST (single-pole, single-throw) switch you prefer. Low current switches will work perfectly well.
- Connect the switch between the “POWER” and “COM” pins of the 980’s “REMOTES” terminal block.

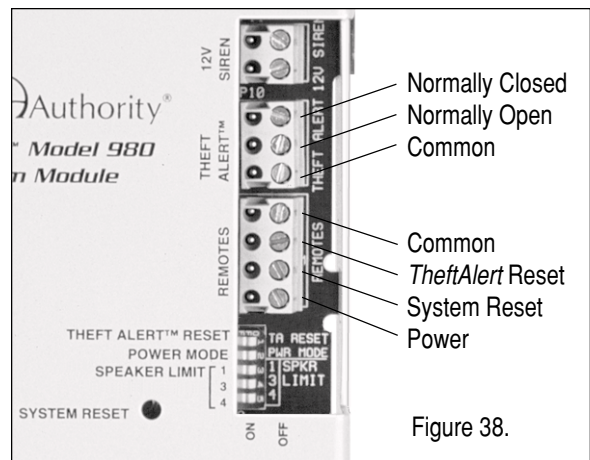

Figure 38.

### TheftAlert™

*TheftAlert* is an optional feature of the Access™ System that provides a merchandise sentinel or security system for the products on display. *TheftAlert* can sound an alarm in the event that products are removed from the display without prior authorization. This feature is available upon request at the time of purchase, or you can install it later. Contact your Audio Authority Account Manager for details.

Once *TheftAlert* is armed, a special monitoring circuit continually looks to see that all electronic products connected to the system maintain continuity to ground. If products are disconnected without prior entry of an authorization code, then *TheftAlert* senses the loss of continuity in the system and sounds an external alarm (not included). No additional circuitry or buffers are ever in the audio signal path with *TheftAlert*.

TheftAlert™ can send output to many types of warning devices, such as sirens, buzzers, lamps, and so on.

- Connect a 12 volt DC siren or other device, drawing less than 1 amp, to the (+) and (-) “12V Siren” terminal block on the Model 980 (see Figure 38).

If you wish to connect *TheftAlert* to an existing alarm or security system’s control box, use the relay contacts of the “TheftAlert” terminal block on the 980’s circuit board. There are 3 pins to consider in this type connection:

COM = Common Ground  
NO = Normally Open Contacts  
NC = Normally Closed Contacts

- Do not exceed a 1 Amp, 120 volt AC load on these relay contacts.

*TheftAlert* can be turned on and off with a 902 or 903 Control Panel. However, if you do not have a Control Panel, you must have a method of “resetting” the *TheftAlert* circuit when the alarm or siren goes off. *TheftAlert* can be reset with a remote switch regardless of whether or not your system has a control panel. Many users who have a control panel prefer a separate reset switch as an addition to the control panel’s reset function.

- Connect a SPST (single pole, single throw) switch between the “TA” (reset) and “COM” pins on the “Remotes” terminal block located on the 980’s circuit board.
- To ACTIVATE the *TheftAlert* circuit, with or without a control panel, cut or remove the wire jumper on the 980 circuit board labeled “Cut To Activate.”
- If you have a control panel, consult your 902/903 User’s Guide for more information on *TheftAlert* secure commands.

## Remote System Reset

There is a “System Reset” button on the 980 that enables the user to reset the system in the unlikely event that the system “hangs up.” Pressing this button will re-boot the entire system. Having a Remote Reset switch is a good idea in any system since the 980 is usually buried inside the display and would not be readily accessible if the system ever needed to be reset. You may wish to “hide” this remote switch from customer access.

- Connect a SPST switch between the “Reset” and “COM” pins on the “Remotes” terminal block located on the 980 (see Figure 38).
- Your system can now be Reset using this remote switch.

## TESTING NETWORK FUNCTION

A. After installation is complete, all the system’s components need to be tested. Apply power to the system and observe the following signs of normal operation:

- The green SilenTouch™ LED is lit on the 980.
- The green POWER or heartbeat LEDs on the switching modules and the 980 are slowly blinking.
- The red 980 LOW VOLTAGE LED is not lit, or very dim.  
**Note:** If the LOW VOLTAGE LED is lit, your system will not function. The system shuts down if the DC power source (usually the battery) is providing 9 volts DC or less. Check the output voltage of your battery and power supply and contact the factory.
- The red TheftAlert™ LED on the 980 is not lit.
- Ignore the color of the 980’s clear LED marked “BUS MONITOR” for the present. Later, when product selections are made, you will notice that the BUS MONITOR LED flickers and is an orange color. This orange flicker is normal. It merely indicates that “traffic” is present on the bus.

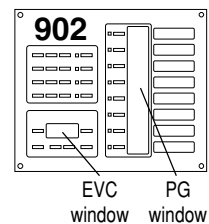

Figure 39.

B. 902/903 Test Sequence. Test the Control Panel (if your system does not have a 902 or 903 Control Panel, skip to step “C” and ignore other references to control panels). Reboot the system (press SECURE, 88, SECURE) and observe the following test results on the Control Panel. If you encounter any problems, keep a note pad handy to record results as they are reported in the Control Panel windows.

1. All display segments and indicators on the control panel are lit briefly (lamp test).
2. The EVC window at the left of the panel displays software version (e.g., 3.3).
3. A System Bus Test is performed. If the word “bUS” flashes in the EVC window, it indicates a problem with a system bus cable or switching module. To find the faulty cable or module, use this process of elimination: carefully unplug portions of the yellow-red-blue-black system bus cable to isolate them from the 980 module, then press any key on the control panel. If “bUS” still appears on the EVC window, plug the cable back in and try a different cable. If “bUS” disappears from the EVC window, you have isolated the module or bus cable that is faulty. Call Audio Authority® Technical Service at 800-322-8346 for assistance with parts replacement.
4. After the bus test, the diagnostic program scans the active range of module addresses in every Product Group. You will observe these module addresses counting up in the EVC window as the product group number is displayed in each group’s Product Group window.

- If the numeric displays begin flashing at any time during the module scan, two or more modules have the same address. Duplicate addresses are disallowed because the control panel is unable to tell two identically addressed modules apart. Note the last group number displayed in the Product Group windows and the module number displayed in the EVC window and try to find two modules that both have this address. For example, if the control panel is flashing, the EVC window displays 002, and the third Product Group window shows S4, you would look for two speaker modules (932) with the same address of “Group 4, Module 02, Right.” Remember that pairs of speaker modules must have the same Group and Module ID address, but must be identified LEFT and RIGHT to avoid a duplication (see page 18).

*Note: In Control Panels, E refers to Electronics switching modules and S refers to Speaker switching modules.*

- If the erroneous address stays in the windows too short a time to catch, press SECURE, 88, SECURE to reboot the system and repeat the test.
- As each new group number appears in a PG window (Product Group, Figure 39), the EVC window counts up the number of modules in that group that can be recognized. Write down the highest number reported in the EVC window and the Group number with it. For each group, compare the reported module tally with a physical count of the modules. For example, your system has four “E Group 0” modules, six “E Group 4” modules, and three pairs of “S Group 4” modules. The top PG window displays “E0” as EVC scans up to 4 (good), the second PG window displays “E4” as EVC scans up to 5 (bad), and the third PG window displays “S4” as EVC scans up to 3 (good). In this case you would look for a mis-addressed, unplugged, or faulty E4 module (Electronics Group 4).
- If the module count in a group does not match the number of modules you actually have, look for disconnected or mis-addressed modules. Also check for gaps in the series of Module ID settings in that group. For example, 0, 1, 2, 4, 5 is not allowed and will be reported as 3 modules; in this case, the modules addressed 4 and 5 must be corrected to 3 and 4, respectively.

C. Test the Product Positions. Use the PSBs (product select buttons) to select each position called for in the following procedures. If your system does not include PSBs, find the extra PSB supplied with the 980 and plug the PSB into one of the small 2-pin PSB headers at each location called for in the following steps.

1. Connect the test PSB to one position on a switching module belonging to each Product Group and press the button. Watch for the following signs of normal operation:

- The test PSB lights.
- The 980 SilenTouch™ LED blinks off momentarily.
- The 980 BUS MONITOR LED flickers orange.
- The product position number that the test PSB is connected to is displayed on the 902 or 903 Control Panel.
- Each product selected with The PSB is displayed in the correct Product Group window on the 902 or 903.

2. Press a lighted PSB in any group.

- The LED goes out.
- The 902 or 903 displays double dashes (– –) in the respective product group window.

3. Select a speaker position using the test PSB, then move the PSB to the same module location on the opposite side of the speaker section of the display.
  - The PSB lights up as soon as you plug it in, showing both left and right speaker positions are selected.
4. Attach the test PSB to a second speaker in a group, press the PSB and hold the button for at least one second.
  - If the speaker limit setting on the 980 is set to 1, the PSB will not come on.
  - If the speaker limit is 2 or higher, the PSB will come on in both the first and second speaker position (factory default is 2, with 980 limit switches all in the OFF position). The 902/903 displays the two speaker positions alternately in the speaker's PG window.

## DISPLAY COMPONENT HOOKUP

It is now time to begin installing the car audio head units, EQs, amplifiers and speakers. If you've followed the instructions so far, you will have a working system in short order. This section assumes that the components have been mounted onto removable panels or onto the front portion of your fixture. You will obviously need to connect the wires from the components to the switching system and DC distribution system, so you may wish to map out a plan for that process that allows easy access to the modules from the front or the rear of your display.

Usually, it works out best to mount the components to be located at the bottom of your display first, and work toward the top of the display so you can avoid masses of hookup wire hanging down from above. Take your time mounting the components and be sure to save their boxes and accessories, so that you can offer your customer a new or almost new unit when you later take the component out of the display.

### 1. Install the First Products

Install one product in each of several groups in order to get a simple system running. For example, install a head unit, a processor (if any), a two-channel amp, and a pair of front speakers (see Appendix B for detailed hookup drawings). Leave your power supply ON and your battery, if any, connected, but be careful using metal tools.

A. Connect a head unit's high/low-level audio outputs and DC power inputs to a product position on the 910 Module.

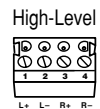

- Connect the low-level output to the red (R) and white (L) female RCA jacks using short, high quality patch cables.
- Connect the unit's front and rear high-level (speaker) outputs to the two terminal blocks next to the "Power" terminal block. Observe the polarity legend printed on the circuit board under the terminal plugs.
- Connect the two-pin plug of the PSB's cable, if PSBs are used, to the small 2 pin headers on the 910 circuit board at the corresponding product position. Press the PSB into the 3/4" hole you drilled earlier in the mounting panel or display fixture. Plug the connector into the PSB with the cable exiting on top as shown.

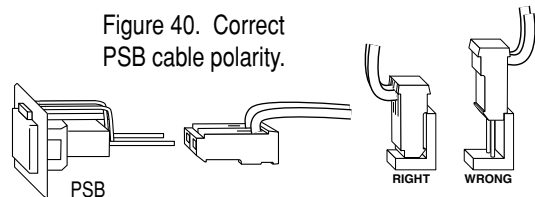

Figure 40. Correct PSB cable polarity.

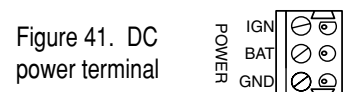

Figure 41. DC power terminal

- Connect the ground lead to the GND terminal.
- Connect the memory lead to the BAT terminal.
- Connect the ignition lead to the IGN terminal.
- Plug an FM antenna cable from the FM Distribution System into the unit's female antenna jack.
- Install the unit in your fixture.

B. Connect a processor's audio inputs and outputs to a 958 in the Processor/EQ Group. Then connect the processor/EQ unit's DC power inputs to a 915X DC Expander Module.

- Connect a high quality RCA patch cable from the 958's LEFT and RIGHT INPUT jacks to the EQ's input.
- Use additional RCA patch cables to connect a corresponding jack pair from the LEFT and RIGHT FRONT OUTPUT to the unit's Front output. Do the same for the unit's Rear and Sub outputs.
- Connect the ground lead to the GND terminal.
- Connect the memory lead to the BAT terminal.
- Connect the ignition lead to the IGN terminal.
- Install the unit in your fixture.

C. Connect an amplifier's audio signal inputs and outputs to a 942 module and DC power inputs to a 916X DC Expander Module. Four DC harness assemblies were included with each 916X.

Connect the amp's audio inputs and speaker outputs a the 942 Module.

- Connect a high quality RCA patch cable from the same numbered 942 LEFT and RIGHT AUDIO jacks to the unit's input.
- Use 14 - 16 gauge speaker wire to connect the unit's Speaker outputs to a corresponding SPEAKER OUTPUT terminal plug.

Now connect the amp's DC power inputs to the 916X connected to its 942 module.

- Connect the amp's ground lead to the BLACK wire in the harness.
- Connect the amp's battery lead to the YELLOW wire in the harness.
- Connect the amp's turn-on lead to the BLUE wire in the harness.
- Plug the connector on the other end of the harness onto a numbered amp position on the 916X circuit board. No smoke and fire? Great!

Install the unit in your display fixture.

D. Install a pair of speakers in the Front Speaker Group.

Note: Factory-wired displays use two position terminal blocks marked (+) and (-) that are pre-wired to 932 Speaker Modules. You may wish to extend the wiring location for speakers from the 932 module to a convenient spot in each speaker cavity in your display.

- Connect the left speaker to one of the 2 position terminal blocks on the Left 932 and the right speaker to the corresponding position on the Right 932. Wire the positive lead to (+) and the negative speaker lead to (-).
- Connect the two-pin plug of the PSB's cable, if PSBs are used, to the small 2 pin headers on the 932 circuit board at the corresponding product position. Press the PSB into the 3/4" hole you drilled earlier in the mounting panel or display fixture.

Note: One PSB will activate both left and right speakers when selected. You may also wish to install a 996 or 997 Product Indicator at the alternate speaker location for easy product selection verification. Product Indicators are merely LEDs; they connect to any switching module in exactly the same manner as PSBs (see pp. 9, 30).

- Install the speakers in the display fixture. Tightly seal all speaker chambers, especially subwoofer enclosures.

## 2. Test Your Initial Product Installation

A. Use PSBs or the Control Panel, depending on how your system is equipped.

- On a 902 or 903, press the first key at the top of the column of 8 Product Group keys. The red LED comes on.
- Enter the number of the first product in the Source Group using the numeric pad. The Product Group Display blinks while receiving your input.
- The Product Group Display stops blinking after two seconds and the selected product comes on.
- Enter the numbers of the remaining test products in their respective Product Groups.

B. Adjust the product controls until you hear music. If none is heard:

- Check for source material (cassette, CD, FM tuning).
- Check your product selection numbers on the control panel for accuracy.
- Check product connections to the switching modules.
- Make sure all products are receiving DC power.
- Check all Group, Module, and programming switch settings. Refer to the configuration on the information boxes and your system plan.

Note: If you make any changes to any module's switch settings, press the System Reset button on the 980 System Module. In systems with control panels, you can also press "Secure, 88, Secure" on the control panel to reset the system. This enables the modules to recognize the new settings.

- Make sure that PSBs, if present, are connected to the correct header position.
- If PSBs are not installed, plug the test PSB that came with the 980 System Module into the respective headers on the switching modules to make sure that the products are currently selected to play.
- Follow the signal path visually through the product hookups and system buses to make sure there are no wiring errors.
- If you are still experiencing difficulties, call Audio Authority's Technical Service at 800/322-8346.

### 3. Connect the Battery

If a battery is to be used as part of your DC power system, install it in the system between the power supply and the DC distribution system you installed earlier.

- A. Locate your battery within 10 feet (3 meters) of the power supply, preferably an Audio Authority Model 277 Hybrid™ Power Source.

**WARNING:** Never allow battery terminals to be shorted to one another. Keep all metal tools away from the battery's terminals, power supply terminals, and all terminals on 916Xs once the battery is connected.

- B. Turn off the power supply. Disconnect the red and black battery leads you connected to it for initial testing and connect them to the red (+) and black (-) battery terminals (see Figure 29 and Figure 42).

- C. Connect the positive (red) cable from the 277 Power Source to the battery as shown. Secure the battery connection with a wing-nut and stud furnished with the Model 277.

- D. Connect the negative (black) cable in the same fashion.

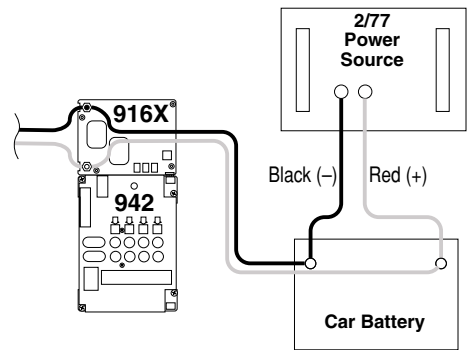

Figure 42. Install the optional car battery between the power supply and the DC distribution system.

### 4. Install the Remaining Products

- Install the rest of the sources, amplifiers and speakers by groups, working from the bottom of the display toward the top (for electronic products).
- Check all connections in each product group as it is completed.

### 5. Test Product Selection

This section covers operation of Access™ Systems using PSBs rather than a Control Panel. For operation of systems utilizing a control panel, please see the separate User's Guide included with the control panel.

- A. Make sure the system is on (check power lights on switch modules).
- B. Select products to play by pressing the PSBs next to one product in each product group. The PSB lights, confirming that the product is selected.
- C. Adjust product controls to get the desired audio level.
- D. Select a new product in any group by pressing its PSB. The previous selection is automatically canceled. Select every product in each group to be certain all products are correctly installed.

### Troubleshooting Noise Problems

Unwanted noises such as hum, transport-related noises, or switching-related popping, etc., sometimes occur for seemingly no reason. The Access car audio system topology combats these noises by automatically double-grounding the inputs of both selected and deselected amplifiers, because a car audio display presents a different electrical environment than a car.

1. If an undesired noise turns up in the audio of one or two products, carefully check the products themselves and their wiring for defects. If a whole group of electronics or a large part of it is affected, review the system wiring—or ask someone else to do it—to uncover anything that may have been overlooked during installation, especially in the type of shielded cables that were used.
2. If noise persists, add 982A isolators in all signal paths between the EQ group and the 980 as shown in Figure 43.

- An isolator placed in-line between the head unit group and the EQ group instead of or in addition to those in Step 2 may improve noise performance even further.

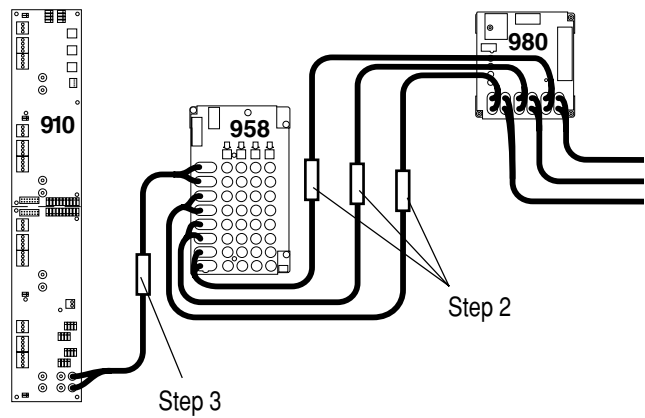
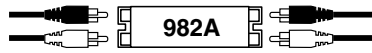

## DEMONSTRATION FEATURES

### 1. Selecting Additional Speaker Pairs with PSBs

The number of speakers per product group that can play at once is limited by the way you set the speaker limit on the 980 module. The Access™ System is capable of playing up to 4 pairs at once, but many receivers are not recommended to play more than one pair simultaneously. Read your product's documentation to determine the setting you should use.

- To add a pair of speakers to the pair currently playing, LPress (press and hold about 1 second) the PSB of the additional pair you wish to add until both pairs are playing.
- To turn any current speaker selection OFF, press its PSB.
- A short press on a new speaker selection cancels all previous selections.

### 2. Deselecting Products with PSBs

Turn any currently selected product OFF by pressing its PSB. The green LED goes out. If you deselect an in-line product, such as an EQ, that product is replaced by a direct signal path if you have installed a bypass (for more information, see "bypass" in the index).

### 3. A/B System Comparison

- A/B comparison may be performed on the 902/903, 906 control panels, or on the 905 IR Remote. For detailed instructions, refer to the control panel User's Guide.
- When you switch a component such as a source, the Access System engages our exclusive SilenTouch™ circuit to mute the audio level briefly (0.15 seconds) during the switching process. This feature quiets all switching noise.

### 4. TheftAlert™ Protection

- TheftAlert™ protects display products from unauthorized removal. When tripped, *TheftAlert* produces an alarm through the external device chosen by your system installer. This feature is optional, and is available through your Audio Authority® Account Manager. You may also install *TheftAlert* after your initial purchase. The special transformer required for this feature can be sent to you at no charge.
- Each switching module monitors the presence of its four products. 932 Speaker Selectors DO NOT have this feature.
- You can control the *TheftAlert* functions via remote key switch, if installed, or from a Control Panel (if so equipped). 902 and 903 Control Panels have an "arm" and "disarm" key sequence for *TheftAlert*. See your Control Panel's User's Guide for more information.
- Set the switch in the OFF position to disarm *TheftAlert* while making product changes or to cancel an alarm. Set the switch in the ON position to arm *TheftAlert*.

Figure 43. Install 982A Ground Loop Isolators on the Front, Rear, and Sub Low-Level Bus in the signal path just before the Model 980. If noise persists, install a 982A in the signal path between the 910 and the 958.

# Reference

## APPENDIX A: SAMPLE SYSTEMS

### System, DC and Signal Bus Wiring Diagrams

- Example System 1: Two-Channel System
- Example System 2: Six-Channel System
- Example System 3: Amp Shared System

## APPENDIX B: PRODUCT CONNECTIONS

### Product to Switch Module Wiring Diagrams

- Head Unit Hookup
- Processor/EQ Hookup
- Model 980 System Module Hookup
- Amplifier Two-Channel Hookup
- Amplifier Four-Channel Hookup
- Amplifier Shared Hookup
- Left/Right Speaker Hookup

## ACCESS WARRANTY

## INDEX

# EXAMPLE SYSTEM 1 TWO-CHANNEL SYSTEM

- Addressing
- System Bus
- DC Bus
- Low-Level Bus
- Speaker Bus
- Amplifier Bypass

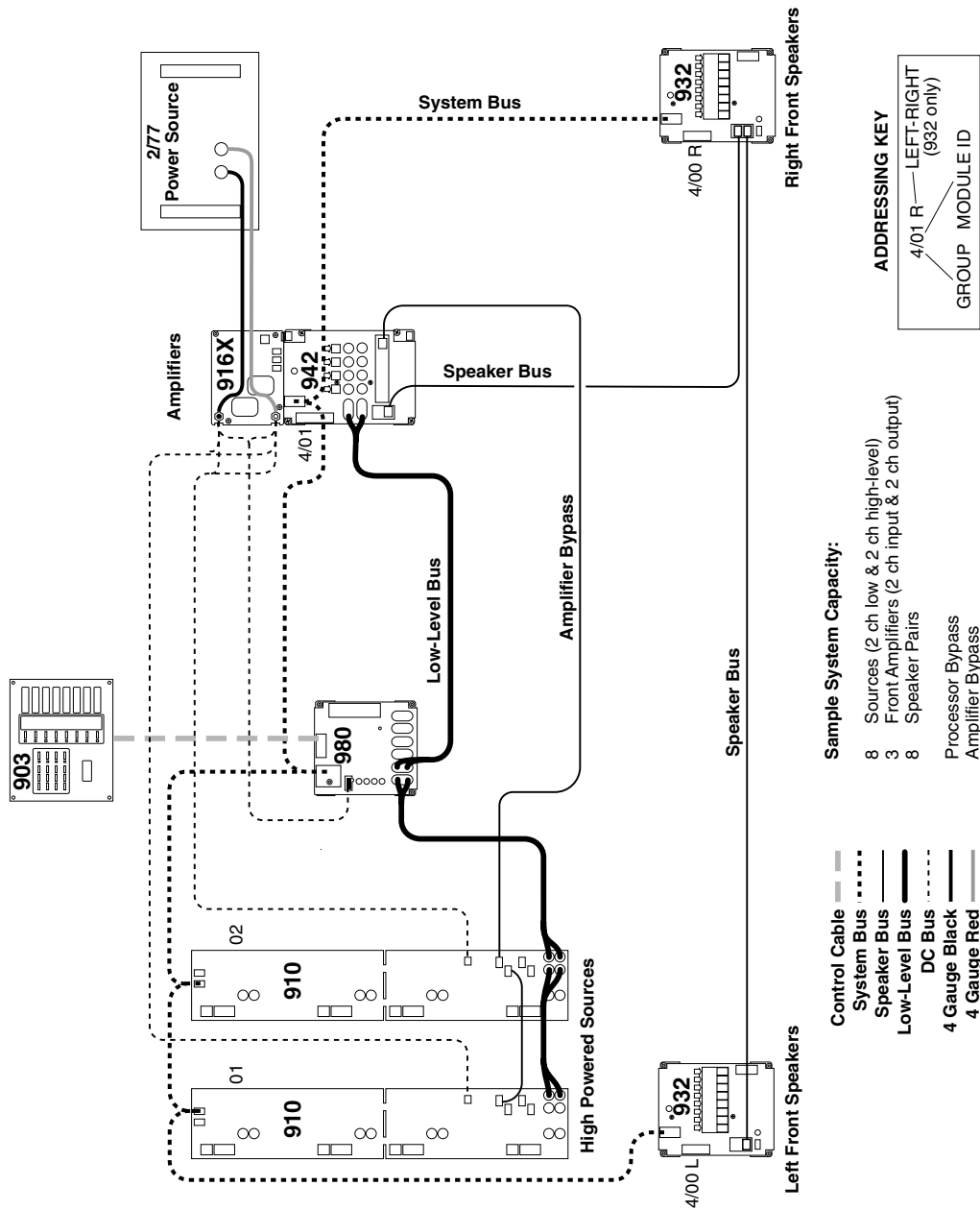

# EXAMPLE SYSTEM 2 SIX-CHANNEL SYSTEM

- System Bus
- DC Bus
- Addressing

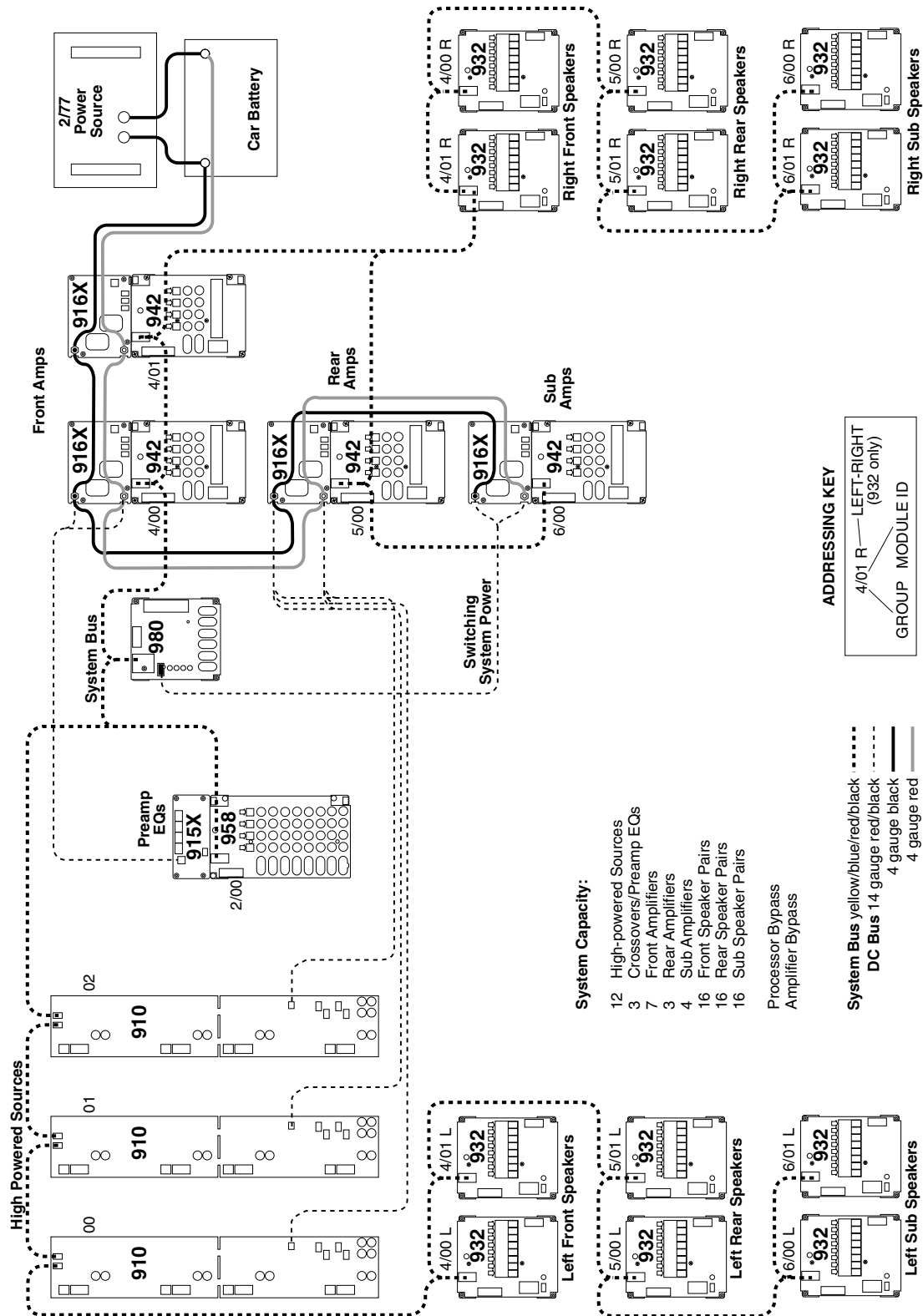

- Low-Level Bus
- Speaker Bus
- Amp Bypass
- EQ Bypass

## EXAMPLE SYSTEM 2 SIX-CHANNEL SYSTEM

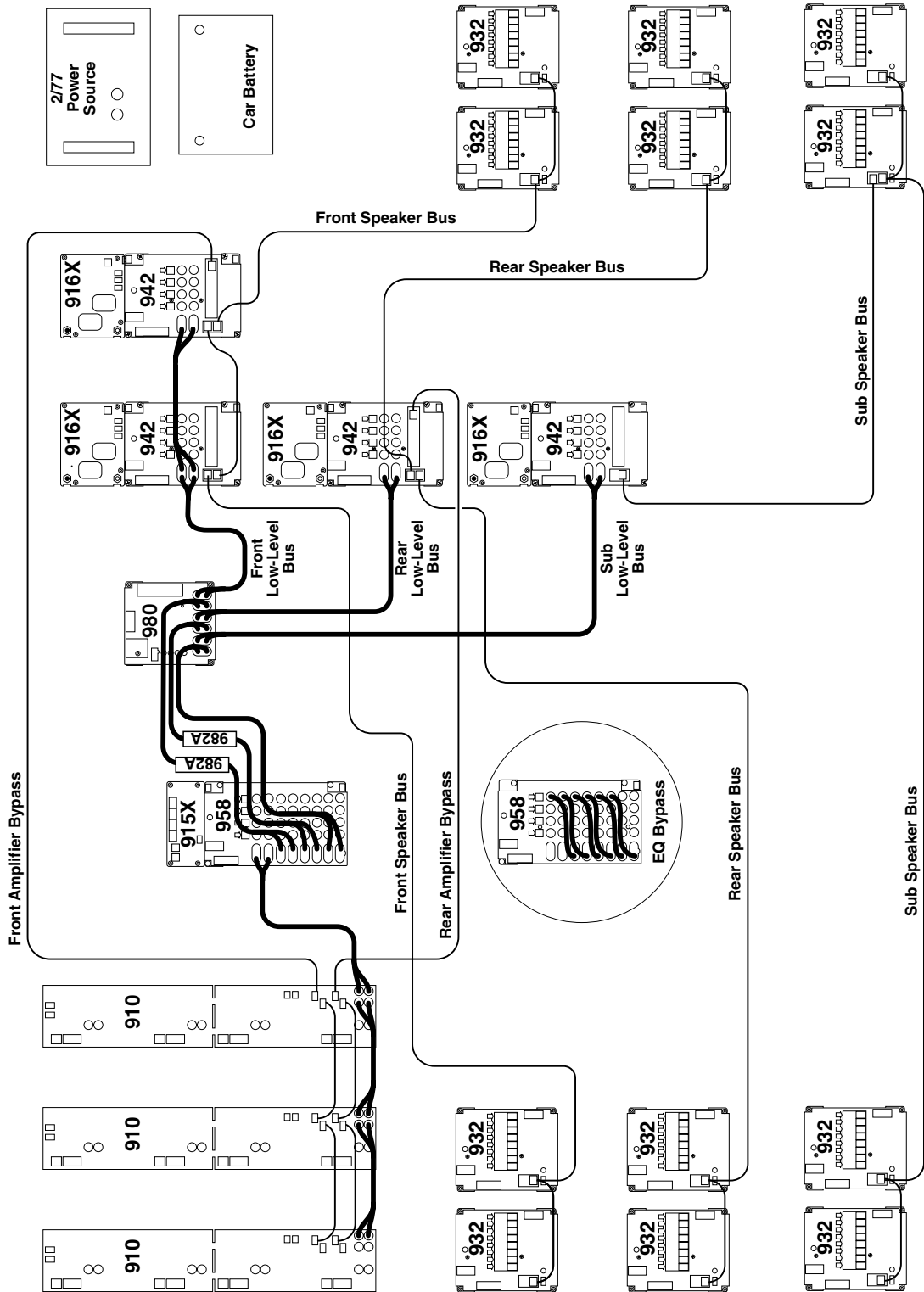

# EXAMPLE SYSTEM 3 AMP SHARED SYSTEM

- System Bus
- DC Bus
- Addressing

For Model 993 Amp Share Adaptor instructions, see page 50.

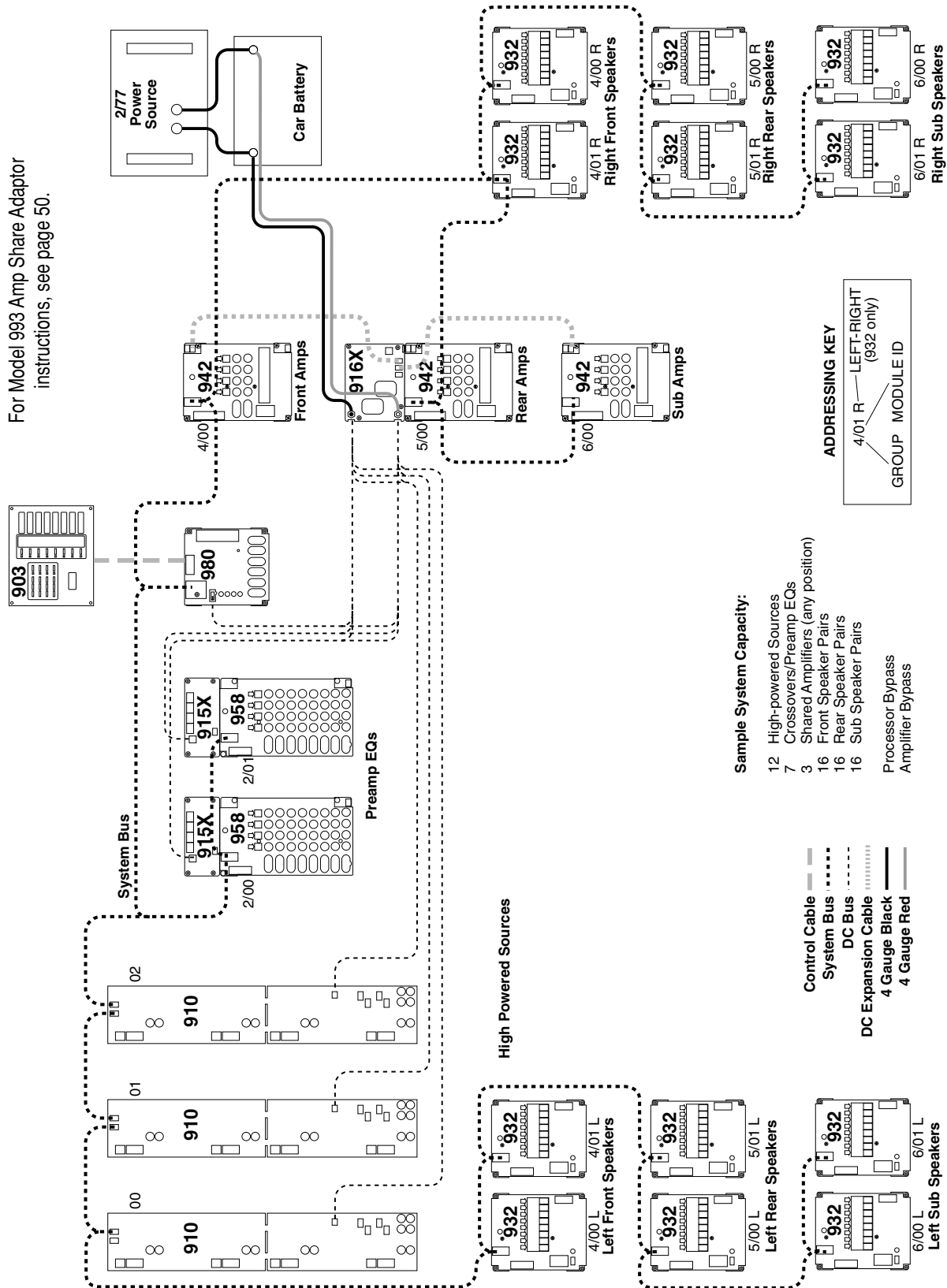

- Low-Level Bus
- Speaker Bus
- Amp Bypass
- EQ Bypass

## EXAMPLE SYSTEM 3 AMP SHARED SYSTEM

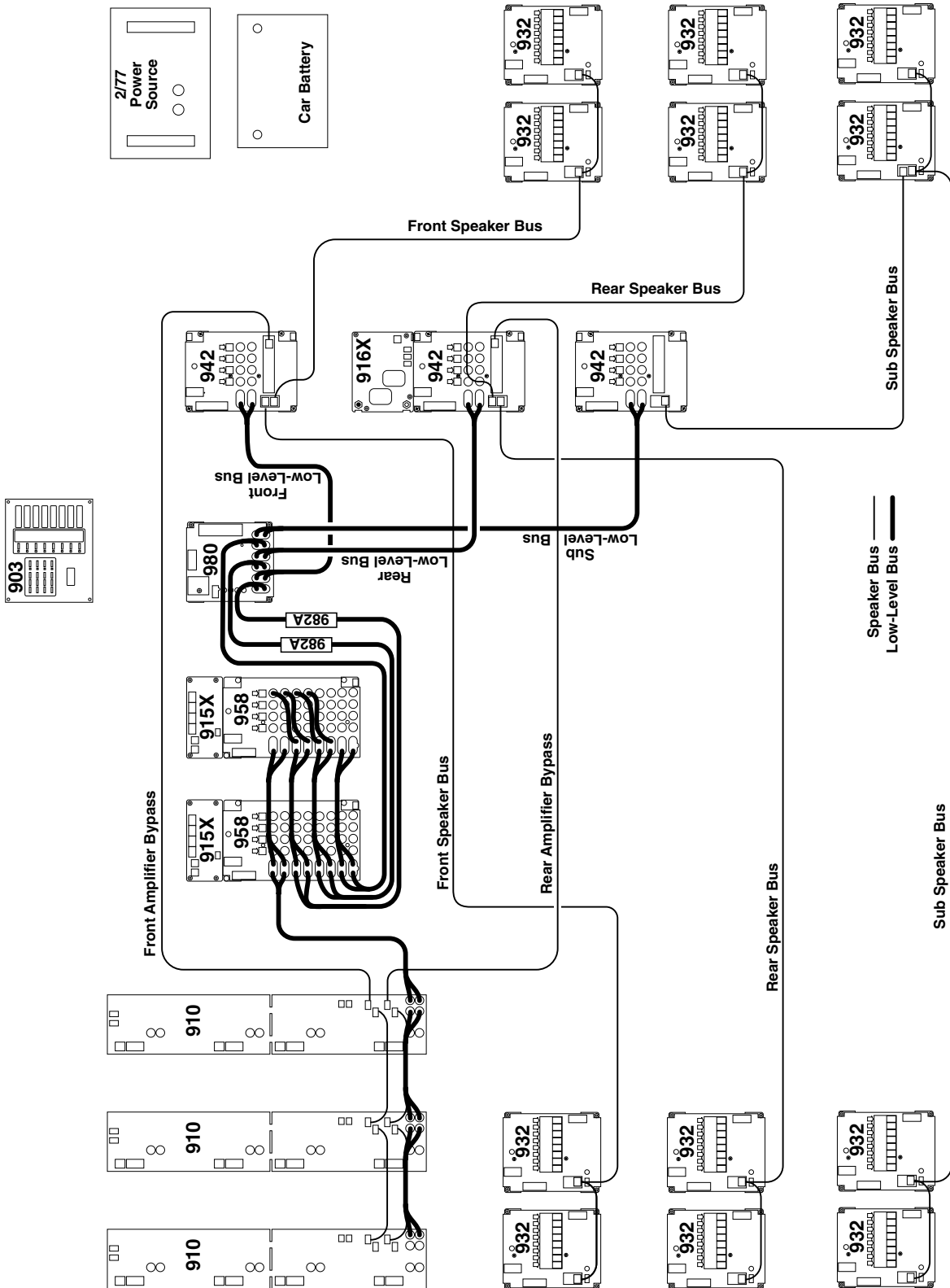

# Model 910 Head Unit Module: 4 Channel High- /2 Channel Low-Level

Convenient source module for (4) Car Audio Sources that includes DC connection (No Model 915X needed). This four position module can be split in half to allow easy vertical installation of six source units.

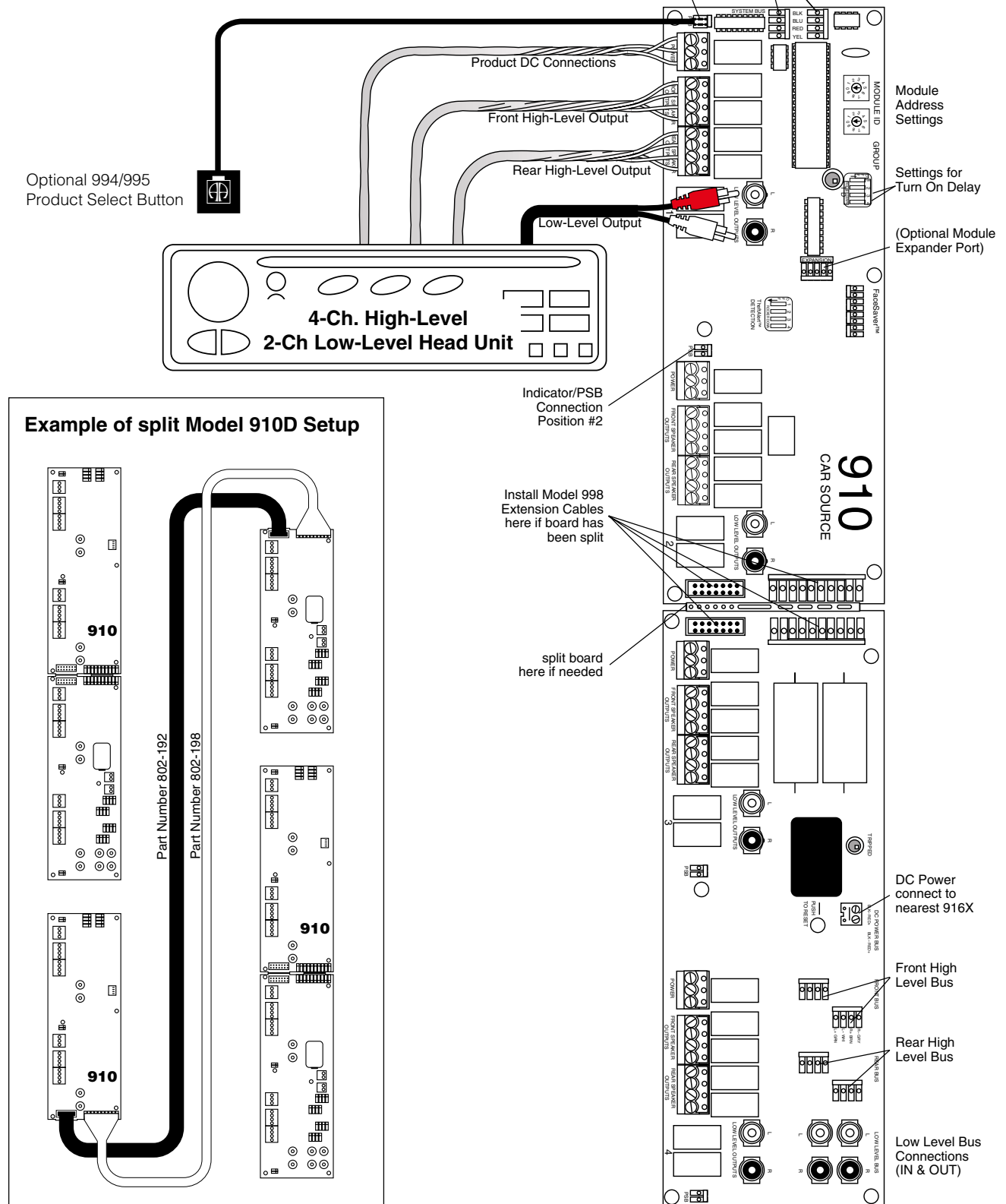

## Processor/EQ: 2 Channel Low-Level Input / 6 Channel Low-Level Output

The same layout applies to 6 and 4-channel processor Product Groups (a 2-channel processor group may use a 922 for input signal and a 920X for output). The Low-Level Bus connections should be routed to the corresponding bus connections on the next module in the Product Group or the Model 980 System Module (front output bus to position "A" on the 980A, rear bus to position "B" & Sub bus to position "C"). See Model 980 Setup Diagram for the next installation step.

If your system includes head units with both low-level and high-level signal output, special wiring is required for setting up the proper installation of Low-Level Bypass (see pp. 12, 42).

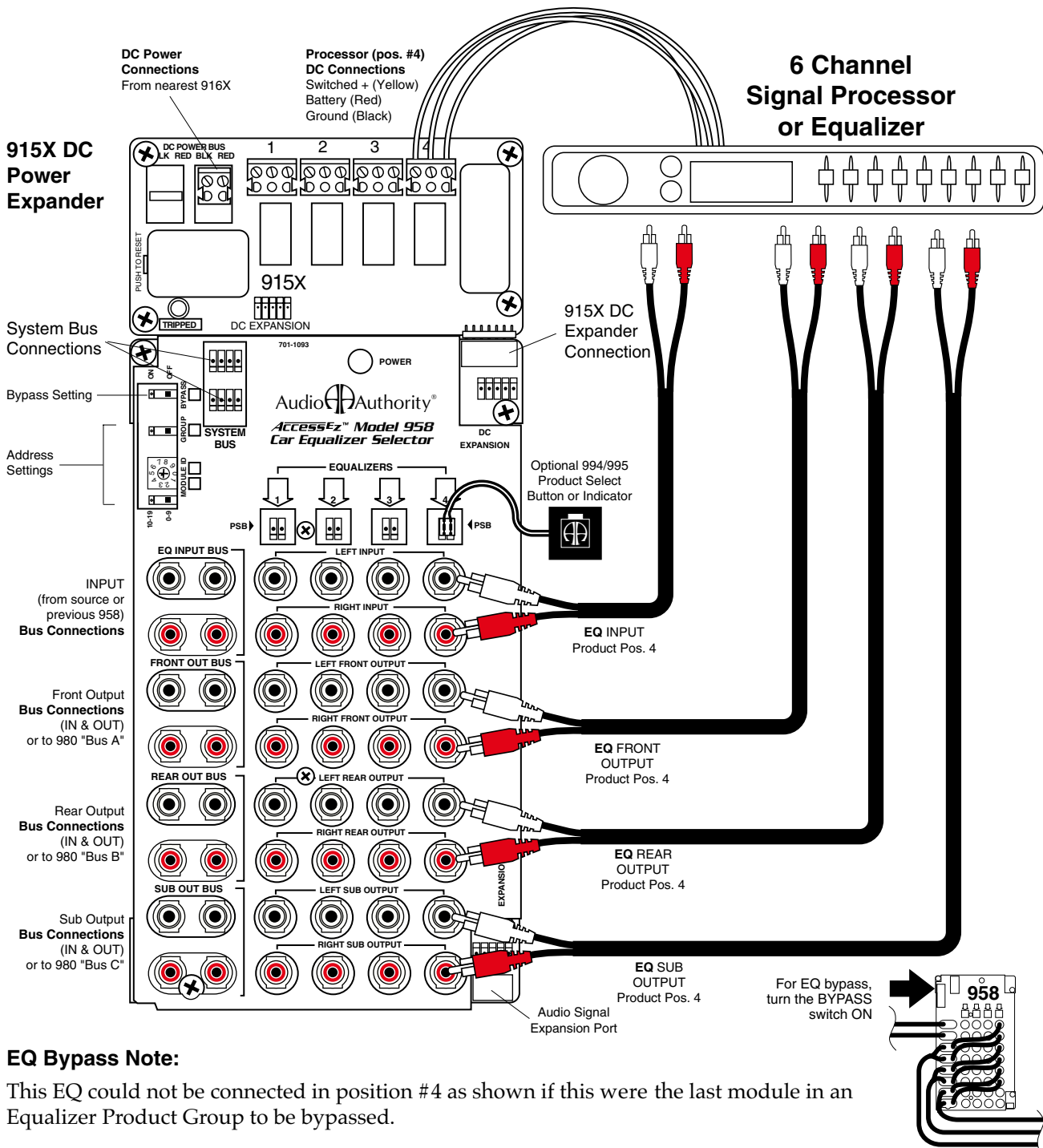

### EQ Bypass Note:

This EQ could not be connected in position #4 as shown if this were the last module in an Equalizer Product Group to be bypassed.

## Model 980 System Module / 2- and 6-Channel Hookup

The System Module is essential for every Access™ system. It makes no difference if selection of product is by Control Panel or by Product Select Buttons or both, therefore, always follow this diagram for proper setup. Concerning signal path, the Model 980EZ will be located just before the amplifier inputs (see Appendix A). In the 2-channel configuration, the Front Inputs and Front Outputs are the only connections that are used. In the 6-channel configuration, all three sets of inputs/outputs are used. The Low-Level buses (e.g., front, rear, sub) continue separately from the 980 on to their corresponding amplifiers or amp groups.

### 2-Channel Setup for 980EZ

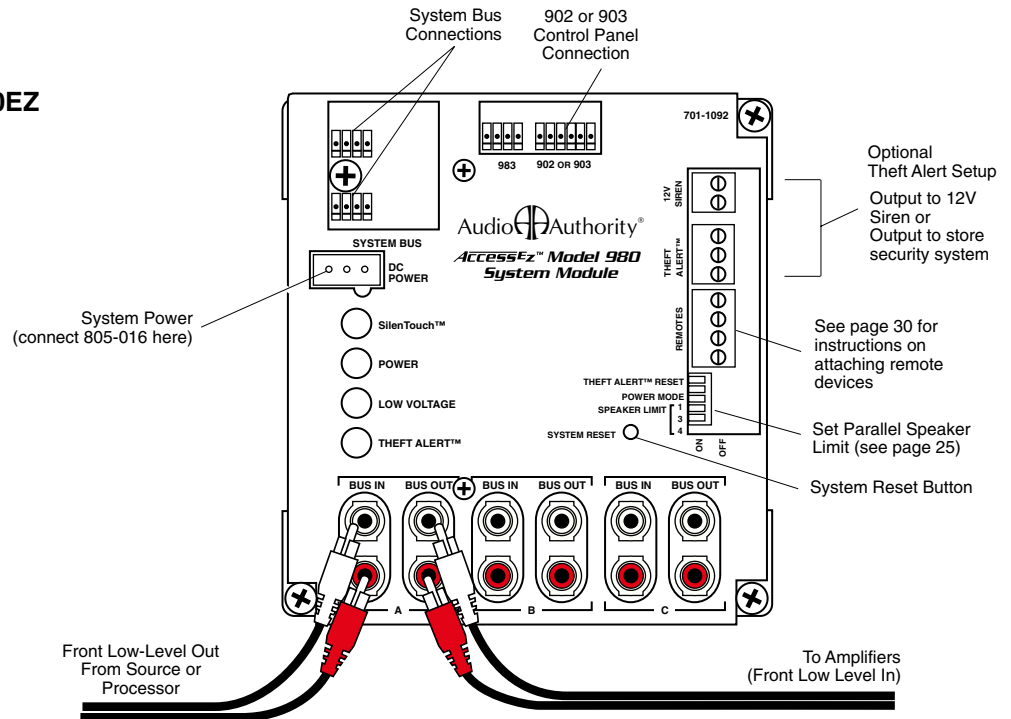

### 6-Channel Setup for 980EZ

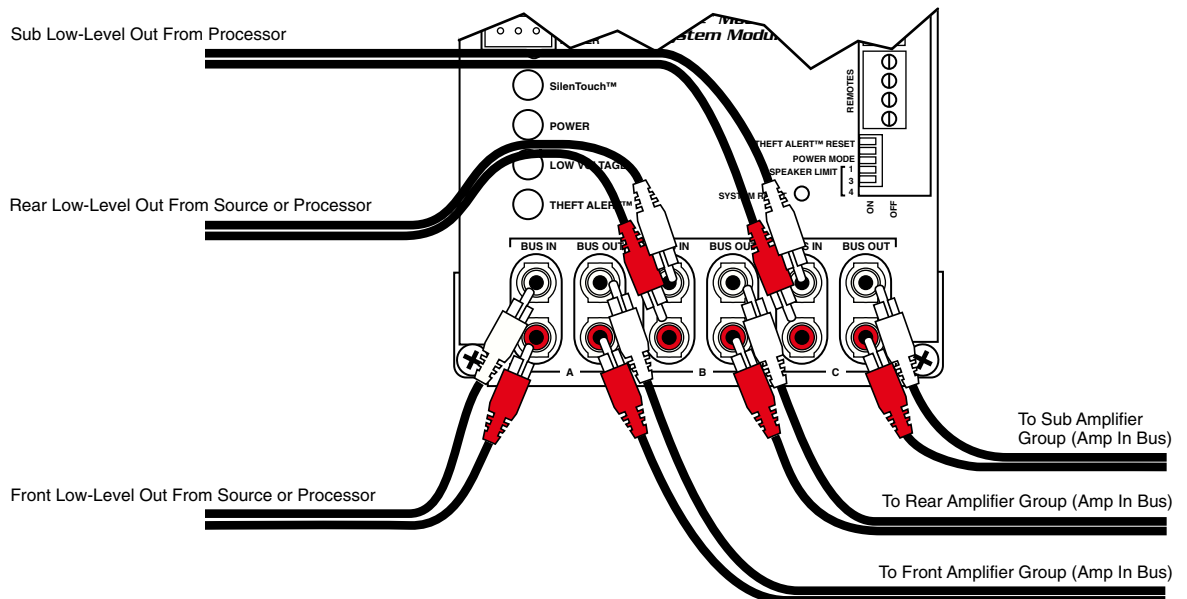

# AMPLIFIERS / 2-Channel Hookup

This drawing shows the basic connections for a 2-channel amplifier. See Appendix A for other system related connections such as System Bus, DC distribution, or Low-Level and High-Level Bus.

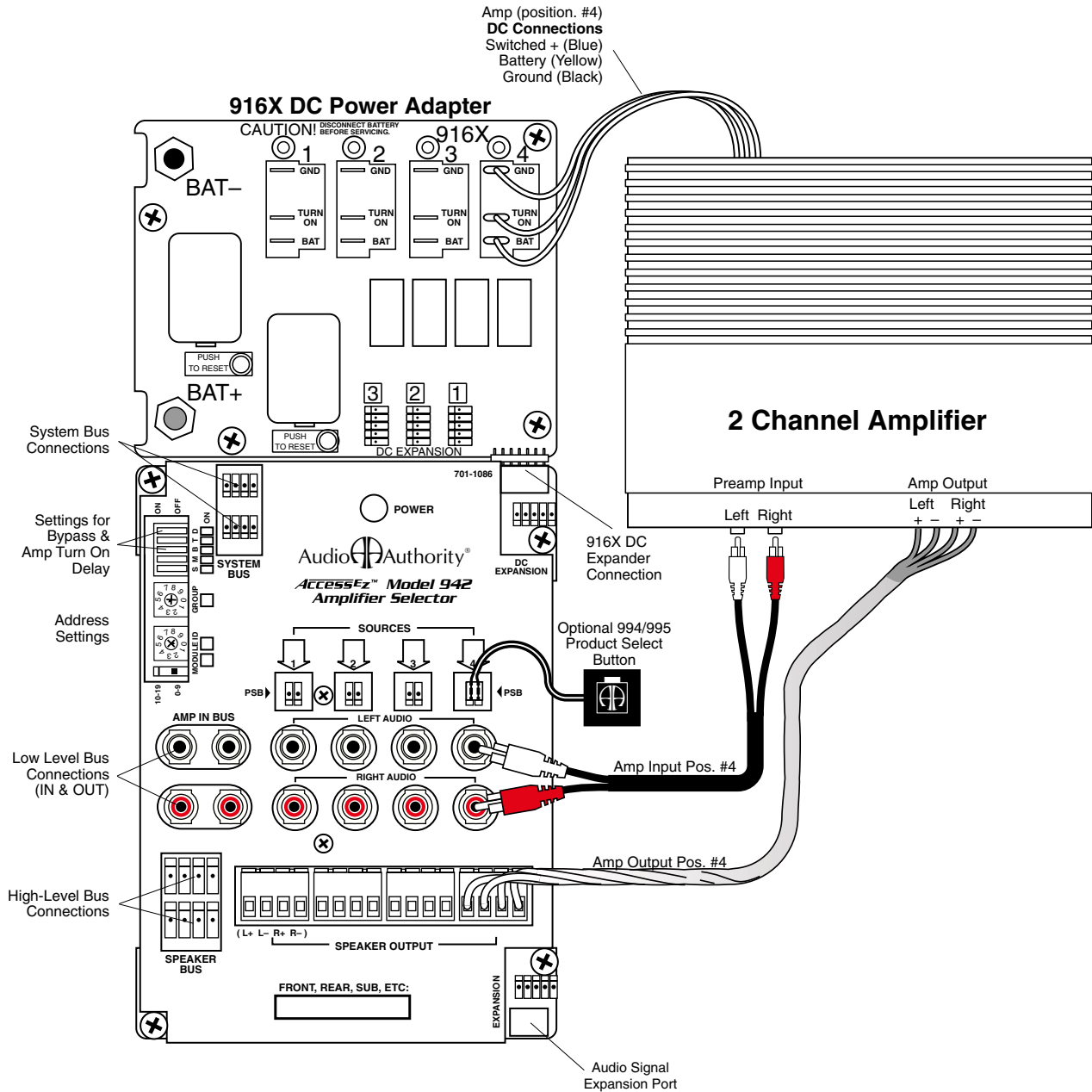

### Amp Bypass Note:

This amp could not be connected in position #4 as shown if this were the last module in an Amplifier Product Group to be bypassed.

# AMPLIFIERS / 4-Channel Hookup

The Module ID for both 942s in a four-channel setup should be the same, but the group number for each should be different. For example, if the front 942 group number is "4," then the rear 942 group number would be "5." Front and Rear Channels of each amp can be selected separately.

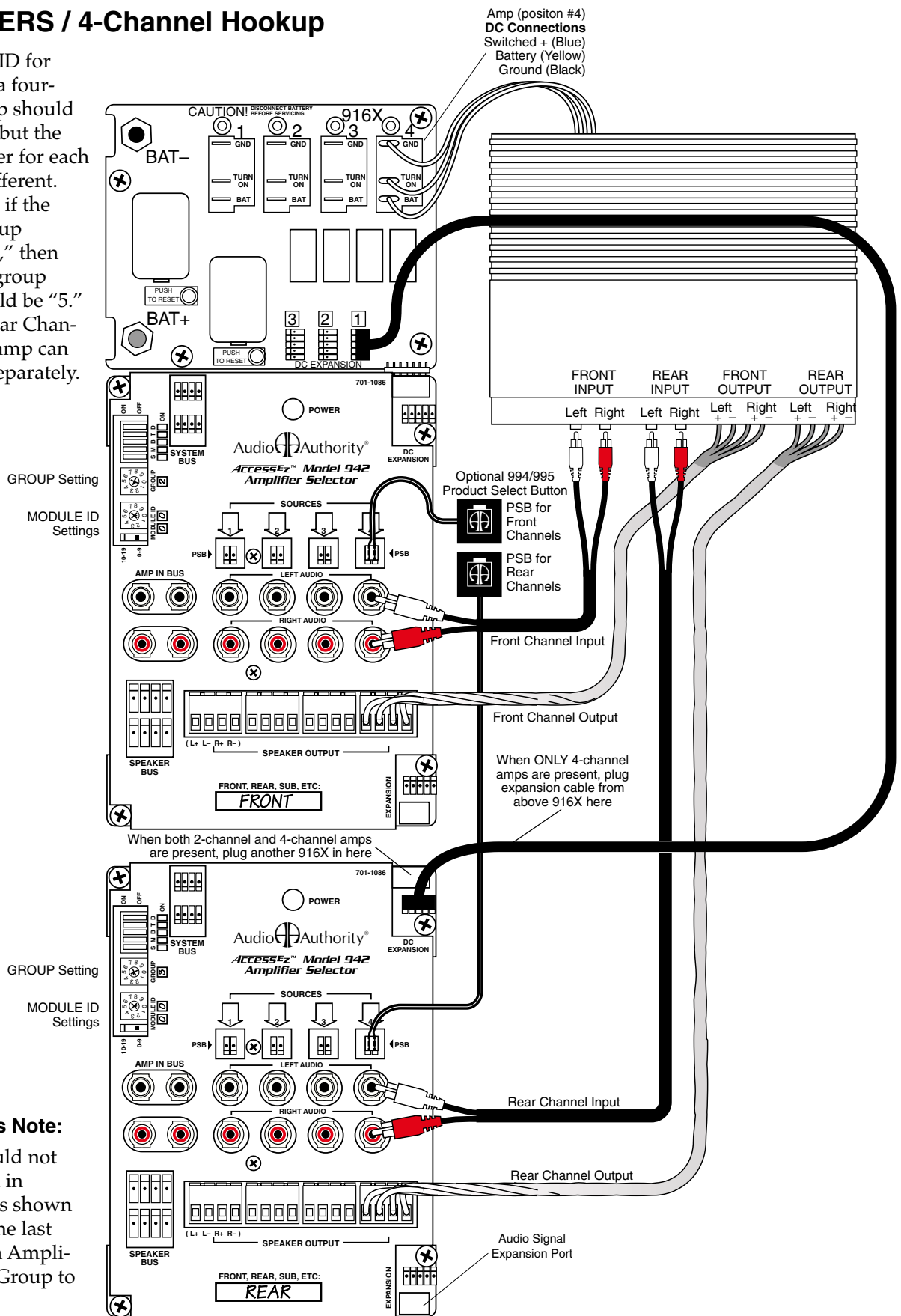

**Amp Bypass Note:**  
This amp could not be connected in position #4 as shown if this were the last module in an Amplifier Product Group to be bypassed.

# Shared Amplifier Hookup

This diagram shows one stereo amplifier connected to all three Amplifier Product Groups so that it can play in the front, rear, or sub position. To add three more shared amplifiers, connect each to its own Model 993 adapter, and then connect the adapter to corresponding positions on each 942 module. If some of your amps will be shared, and some not shared, contact Audio Authority® at the phone number below for assistance.

First, mount the switching modules inside your display according to your system plan. Then use the screws provided to mount each amp's 993 adapter inside the cabinet or on the back of the amplifier display panel near the amplifier to be shared. Connect the Input and Output cables from each 942 module to the 993 adapter as shown. Connect the amplifier to the adapter using the "SHARED AMP" terminals and jacks on the 993. Contact Audio Authority® Technical Service at the phone number below with questions.

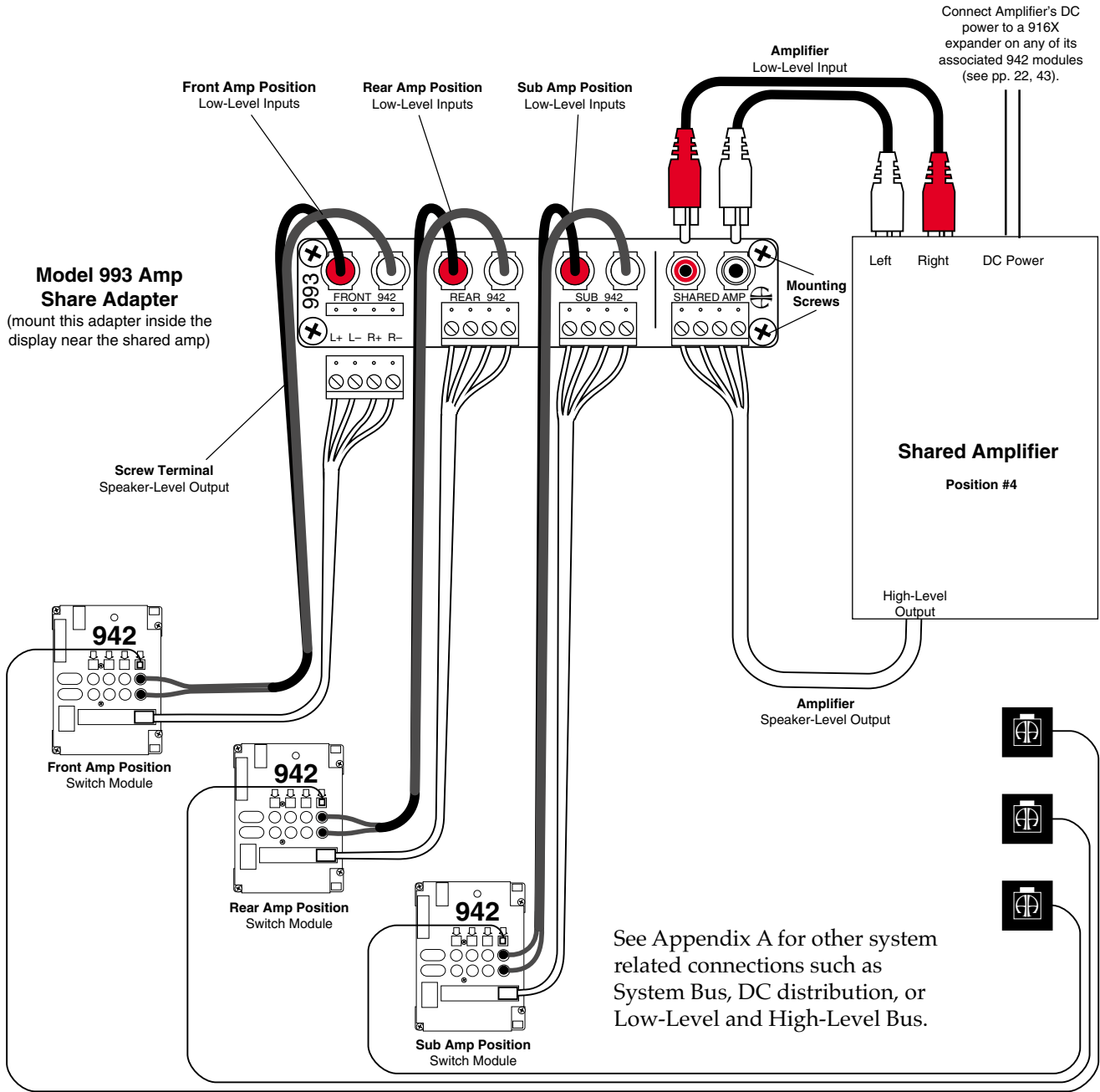

Note: This drawing is not to scale.

## Left/Right and Mono Speaker Hookup

Model 932 Speaker Modules can be configured to function as left, right or mono modules. The slide switch on the left side of the module is marked LEFT and RIGHT. Position the slide switch to LEFT for left channel function and toward RIGHT for right channel or MONO function. (If used for mono operation there will not be a corresponding "L" module.)

Model 932s are unique in that they share the same GROUP Address with the amplifier group with which they operate. For example, if the front amp GROUP number is "4," then the front speaker GROUP number would also be "4." Additionally, LEFT and RIGHT modules have the same MODULE ID; here is an example: For speakers 1-8, both LEFT & RIGHT 932 modules have the address: 4/00 (GROUP=4 / MODULE ID=00). For speakers 9-16 both LEFT & RIGHT 932 modules have the address: 4/01 (GROUP=4 / MODULE ID=01) etc...

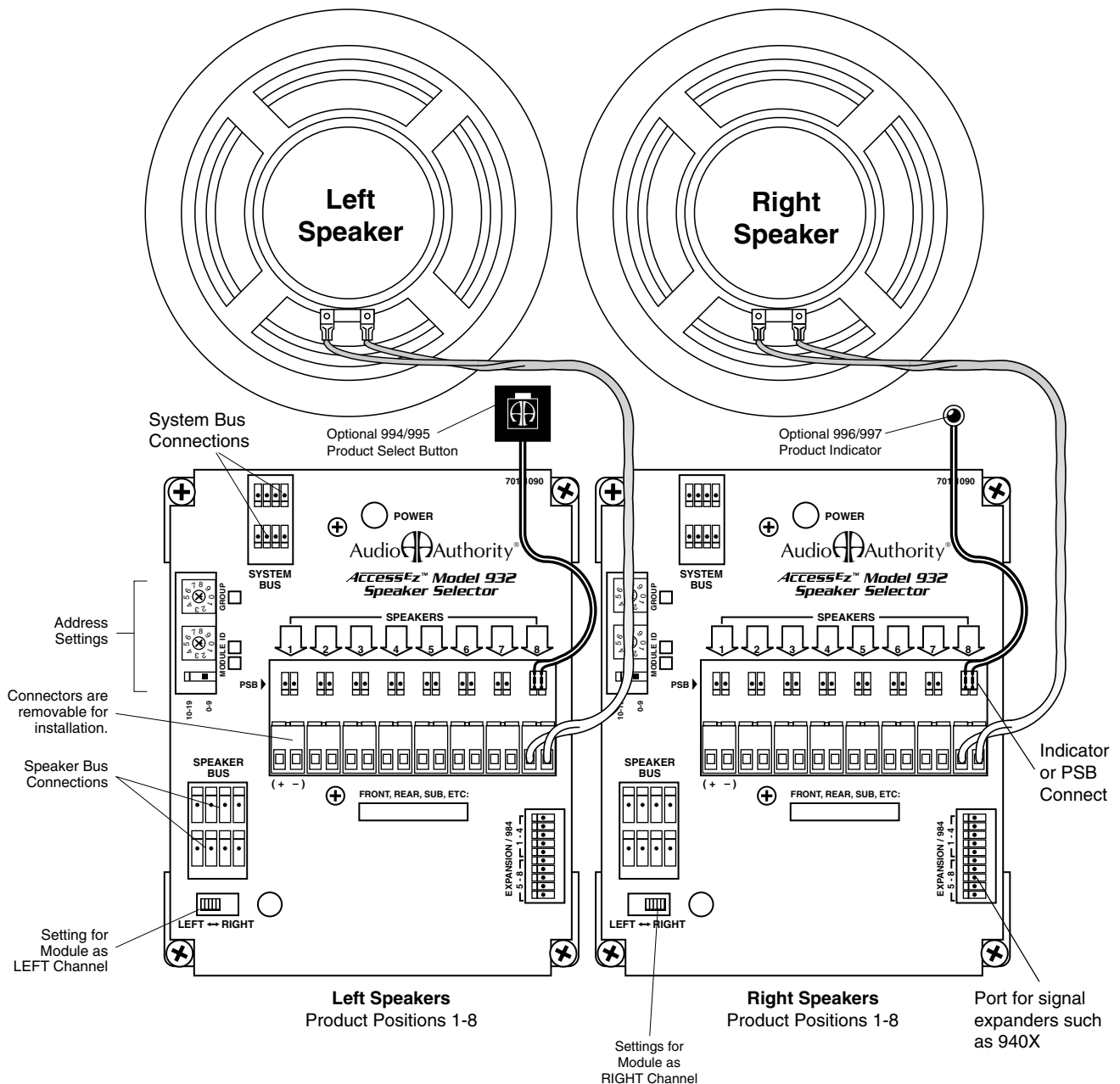

# ACCESS™ WARRANTY

## Limited Warranty

Should any Access™ product become defective in materials or workmanship within 5 years from the date of purchase, Audio Authority® Corporation guarantees to the original purchaser that it will replace the defective product at no cost. This warranty is not applicable for products which, in our opinion, have been damaged, altered, abused, misused, or improperly installed.

## Warranty Service Procedures

If you suspect a product defect, contact the Audio Authority® Technical Service Department by calling 800/322-8346 or 859/233-4599 for assistance in verifying the problem. If a defect is found, a replacement product will be shipped immediately, prepaid via UPS or FedEx Ground, on a defect-exchange basis and a Return Authorization number will be issued for the defective product. At the time of shipment, the replacement product is invoiced to the customer, secured via a bank card, and later credited in full upon inspection of the defective product. A bank card sales draft is executed for the cost of the replacement product and held for 14 days to allow the customer time to return the defective product. If the defective product is not received within 14 days, the bank card sales draft is deposited. All returns for credit must be freight prepaid.

Alternatively, if the customer has previously established open account terms, the invoice amount can be charged to his account and later cleared with a corresponding credit memo upon receipt and inspection of the defective product. Similarly, the defect-exchange transaction may be handled by COD, in which case Audio Authority® will issue a refund check upon inspection of the defective return.

Alternate methods of return shipping (UPS Red, Federal Express, DHL, etc.) are available, but at the customer's expense.

## Defects Within the First 30 Days

Replacements for products found defective within the first 30 days from date of sale, will be shipped via overnight courier, freight paid by Audio Authority®.

## Out of Warranty Service

Products not within the terms of the Access™ Warranty may be returned to our factory, freight prepaid, for repair at a labor rate of \$35/hour (1 hour minimum) plus parts and return freight. Repairs are normally shipped within 2 working days via UPS or FedEx Ground unless requested otherwise. Payment for repairs is made via bank card or COD unless other arrangements are requested and approved.

Alternatively, out-of-warranty repairs may be accomplished on a defect exchange basis. The customer will be invoiced, per the terms above, at the current dealer cost for the replacement product. When the defective product is returned and inspected, a partial refund or credit will be issued based on its condition and the repair costs.

For future reference, please record below:

Date of Purchase: \_\_\_/\_\_\_/\_\_\_

Invoice No: \_\_\_\_\_

# Index

## PRODUCT NUMBERS

12V Siren terminal block on  
980...31

2-channel amplifier hookup...48

2-channel system diagram...40

277 Power Source operation...24

4-channel amplifiers...13

6-channel amplifiers...13

6-channel system example wiring  
diagram...41

902 Control Panel...8

902 Control Panel installation...28

902/903 Control Panel in example  
wiring diagram...43

902/903 diagnostics...32

902/903 Programming  
Switches...29

902's calibration microphone...28

903 Control Panel...8, 9

903 Control Panel installation...28

904 or 904V and Systems Product  
Group...29

904 Product Group Expander...9

904V Product Group Expander  
and Volume Control...9

905 IR Remote...9

905 IR Remote and control  
panels...29

905 IR Remote Control...8

905 IR Remote Control to select  
products...7

910D and Product Select  
Button...45

910D for head unit switching...12

910D Head Unit Selector...9

910D in split position...45

915X and 958 hookup  
diagram...46

915X and DC distribution...23

916X and DC distribution...23

920X Low-Level Expansion  
Module...10

922 Low-level Selector...9

924X Low-Level Expansion  
Module...10

932 Speaker Selector...14

932 Speaker Module hookup  
diagram...51

932 Speaker Selector...9

940EZ High-level, Selector...9, 10

940EZ Module and speakers...14

940X High-Level Expander  
Module...10

942 Modules and amp  
sharing...50

958 Module and EQ bypass...23

958 Module hookup diagram...46

970 RS232 Serial Interface/PC  
Interface...10

971 Infrared Control Module...10

975 FM Distribution Amp...26

977 Digital Audio Adapters...10

977 FM Distribution...10, 11

980 Module and control panel  
installation...28

980 System Module  
Accessories...31

980 System Module and DC  
power...24

980 System Module location...19

980EZ System Module...10

981 DC Eliminator...10

982A and noise problems...37

982A Low-Level Isolator...10

983...19

983 Four-Channel AutoMatch  
Module...11

983 Module placement...19

987 Equal Volume Comparison...8

987 EVC Audio Level Module...11

987 EVC Control Module  
placement...19

987 EVC Module and control  
panel installation...28

988 Module settings...18

988 programming switches...18

988 Volume Control Panel...9

990 External Infrared  
Receiver...11

990 Remote Infrared  
Receiver...29

993 Amp Share Adapter,  
about...11

993 Amp Share Adapter  
hookup...50

994/995 PSB connection on  
910D...45

9A80 Crossover...10, 12

## A

A/B System Comparison...38

Add a pair of speakers with  
PSBs...38

Additional Speaker Pairs...38

Address and Other Settings...15

Addressing for 4-channel  
amps...49

Alarm system installation...31

Alarms and TheftAlert™...6

Amp shared system example  
wiring diagram...43

Amp sharing...13

Amp sharing and 993 Module  
hookup...50

Amplifier Bypass and system  
planning...14

Amplifier and EQ bypass...22

Amplifier Bypass example wiring  
diagram...40

Amplifier installation...35

Amplifier Product Groups...13

Amplifiers / 2-Channel...48

Amplifiers / 4-Channel  
Hookup...49

Antenna Distribution System...26

AutoCal and 902...8

AutoDamping and 940EZ...14

AutoDamping™...5

AutoLimiting and 987...11

AutoMatch Module...11

AutoMatch Module mounting  
location...19

Aux IR port and 902 Control  
Panel...29

## B

BAT+ connections on 916X...23

Battery lead wire testing  
hookups...24

Blinking numeric displays on 902/  
903...33

Booster Amps and Model 983...19

Boosters. *See also* Two-channel  
Boosters and powered EQs...13

Bus cable installation...20

Bus, definition of...5

Bus extension cables...20

Bus fabrication...20

bUS flashing in EVC window...32  
BUS MONITOR LED on 980...32  
Buses, explanation of...7  
Bypass and EQ group planning...12  
Bypass and programming switches...18  
Bypass, definition of...5  
Bypass example wiring diagram...40

## C

Calibration microphone and 902 installation...28  
Calibration of speaker volume...8  
CD Changer Distribution...10, 11  
CD Changers and DC power...23  
Choosing switch modules...12  
Comparing A/B systems...38  
Components of the Access™ System...8  
Computer for product selection...7  
Connecting the battery...37  
Connector polarity...20  
Continuous Power Mode...25  
Control panel cut-out sizes...28  
Control Panel, definition of...5  
Control Panel installation...28  
Control Panel testing...32  
Control Panel to select products...7  
Control Panels...8  
Crossover installation...35  
Crossover, Model 9A80...10  
Crossover switching...12

## D

DC Bus wiring diagram...40  
DC Eliminator...10  
DC Expander Module installation...19  
DC Power Bus and 910D...24  
DC Power Distribution Cables...23  
Dedicated Crossover...12  
Dedicated crossover...12  
Delayed Conserve Power Mode...25  
Demonstration Features...38  
Deselecting Products with PSBs...38  
Diagnostics for 902/903...32  
Diagnostics on 902...8  
Digital Audio Adapters...10  
DIP switches...18  
Display component hookup...34  
Duplicate addresses...33

## E

EQ and Amplifier Bypass...22  
EQ Bypass...46  
EQ bypass hookup...23  
EQ installation...35  
EQ, processor, or crossover hookup diagram...46  
Equal Volume Comparison...8  
Equalizer switching...12  
EVC...8  
EVC Audio Level Module...11  
EVC Control Module location...19  
Expander Module installation...19  
Expander Modules, definition of...6  
Expanders for 902/903...29  
Expansion ports...19

## F

F-to-Motorola cables...26. *See also* Antenna Distribution System  
Flashing numeric displays...33  
FM Distribution System...26  
Four-channel amp addressing...49  
FRONT HIGH-LEVEL BUS (bypass hookup)...22  
Front/Rear/Sub example wiring diagram...41

## G

Green/white/brown gray cable...20  
Ground loop isolator, installation of...37  
Ground loops and 982A...10

## H

Hardware installation...3, 19  
Head unit DC connection...45  
Head unit installation...34  
Head unit selector...9  
Head unit switching...12  
High-level Bus (Speaker Bus)...21  
High-Level Bus and bypass from 910D...22  
High-Level head unit connections...45  
Hum, troubleshooting...37

## I

Identification boxes...18  
Indicator LED installation...30  
Infrared Control Module...10

Infrared Receiver...11  
Install remaining products...37  
Installing bus cables...20

## K

Kit 17 and FM distribution...10  
Kit16 and FM distribution...10

## L

Left-Right switch...18  
Left-Right switch and Model 932...51  
Left/Right Speaker Hookup...51  
Lock out on 902...9  
LOW VOLTAGE LED...32  
Low-capacitance RCA patch cables...20  
Low-level Bus...20  
Low-level bus example...7  
Low-Level Bus example wiring diagram...40  
Low-Level Bus installation...21  
Low-level bypass hookup...23  
Low-level signal...7

## M

Microphone installation (902)...28  
Model 910 Head Unit hookup diagram...45  
Model 980 2-Channel hookup...47  
Model 980 6-Channel Hookup...47  
Module count on 902/903...33  
Module, definition of...6  
Module ID and 4-channel amps...49  
Module ID and address settings...15  
Module ID settings...16  
Mono Speaker Hookup and addressing...51  
Multi-channel displays...12  
Multiple speaker pair selection...38  
Multiple speaker pairs in parallel...18

## N

Noise problems...37  
Numbering the Product Groups...15

## O

Open or vacant headers...21  
Optical Digital Audio Adapters...10

## P

Parallel Speaker Limit settings...25  
PC Interface...10  
Position #4 and bypass...48  
Position 4. *See* Bypass  
Position, definition of...5, 6  
Power LED...32  
Power Memory Mode...25  
Power Mode settings...24  
Power Supply. *See also* Hybrid™  
    Power Source  
Power supply hookup...24  
Power Supply Ventilation...24  
Powered EQ Product Groups...13  
Powered Equalizers and EQ groups...12  
Processor installation...35  
Processor switching...12  
Processor/EQ hookup diagram...46  
Product Group, definition of...6  
Product Group lock out on 902...9  
Product Groups about...12  
Product Groups and the 902...15  
Product Indicators...9  
Product Select Button installation...30  
Product Select Button on 910D...45  
Product Select Button testing...33  
Product Select Buttons...9  
Product selection...7  
Programming Switches on the 902/903...29  
PSB...7. *See also* Product Select Button  
PSB, definition of...6

## R

RCA patch cords...20  
RCA patch cords and Low-Level Bus...21  
REAR HIGH-LEVEL BUS (bypass hookup)...22  
Remote Control and 902/903...8, 29  
Remote Power Switch...31  
REMOTES terminal block on 980...31  
Resetting TheftAlert™...31  
RF Antenna Distribution System...26  
RS232 Serial Interface/PC Interface...10

## S

Sample wiring diagram...40  
Security system installation...31  
Selecting Products...7  
Shared amplifier hookup...50  
Signal Buses, different types...7  
SilenTouch, definition of...6  
SilenTouch in systems with 988...18  
SilenTouch LED and normal operation...32  
Siren installation...31  
Six-channel system example wiring diagram...41  
Software version...32  
Source Bus installation...21  
Source selector...9  
Speaker Bus...20. *See also* Speaker Bus Installation  
Speaker Bus example wiring diagram...40  
Speaker Bus installation...21  
Speaker extension...20  
Speaker Hookup...51  
Speaker Limit...18  
Speaker Limit and 988...18  
Speaker Limit settings...25  
Speaker Module addressing...51  
Speaker Product Groups...14  
Speaker selector...9  
SPL AutoLimiting and 987...11  
SPL on 902...9  
SPST (single-pole, single-throw) switch...31  
Switch Settings S M B T D...17  
Switching Modules, definition of...6  
System Bus...20  
System Bus, definition of...5, 7  
System Bus example wiring diagram...40  
System bus extension...20  
System Bus Test...32  
System, definition of...6  
System extension...20  
System Module Accessories...31  
System Modules, definition of...6  
System Reset and remote switches...32  
Systems Product Group...8

## T

Termination plug for RF distribution system...26  
Test product selection with

PSBs...37

Testing initial product installation...36  
Testing Network Function...32  
Testing speaker limit...34  
Testing your system...24  
TheftAlert, definition of...6  
TheftAlert installation...31  
TheftAlert LED and normal operation...32  
TheftAlert operation...38  
Timeout Minutes switch...18  
Timeout minutes switch...18  
Tools you will need...15  
Troubleshooting noise problems...37  
Two-channel Booster Amplifier. *See also* Boosters  
Two-channel example system...40

## U

User Interfaces...8

## V

Vacant headers...21  
Ventilation of Power Supply...24  
Volume control module...18

## W

Warranty...52  
Wiring diagram for 2-channel system...40

## Y

Yellow/red/blue/black cable...20