

REV.	DESCRIPTION	DATE	APPROVED
------	-------------	------	----------

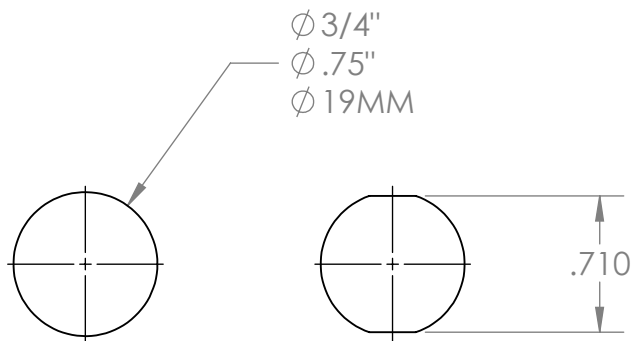

PANEL CUTOUT

DIMENSIONS ARE IN INCHES TOLERANCES: FRACTIONAL ± ANGULAR: MACH ± BEND ± TWO PLACE DECIMAL ± THREE PLACE DECIMAL ±	DRAWN	NAME	DATE	 CORPORATION LEXINGTON, KENTUCKY
	CHECKED			
MATERIAL SEE NOTES	PROPRIETARY AND CONFIDENTIAL			PART NO.
FINISH SEE NOTES	THE INFORMATION CONTAINED IN THIS DRAWING IS THE SOLE PROPERTY OF AUDIO AUTHORITY. ANY REPRODUCTION IN PART OR AS A WHOLE WITHOUT THE WRITTEN PERMISSION OF AUDIO AUTHORITY IS PROHIBITED.			TITLE
DO NOT SCALE DRAWING	SIZE A	DWG. NO.	REV. A	
	SCALE: 1:1	WEIGHT:		SHEET 1 OF 1