

Sample Composite Video Distribution System

- Dedicated Source with composite video and left/ right audio output.
- 12 Televisions or Video Monitors with or without Stereo Audio inputs.
- Audio can be connected to the TV monitors, and/ or drive a dedicated receiver and speaker package.
- Each 985 can be powered by a 805-021 wall pack (shown) or up to eight 985s may be connected together with System Bus and powered by a 805-016 power supply.

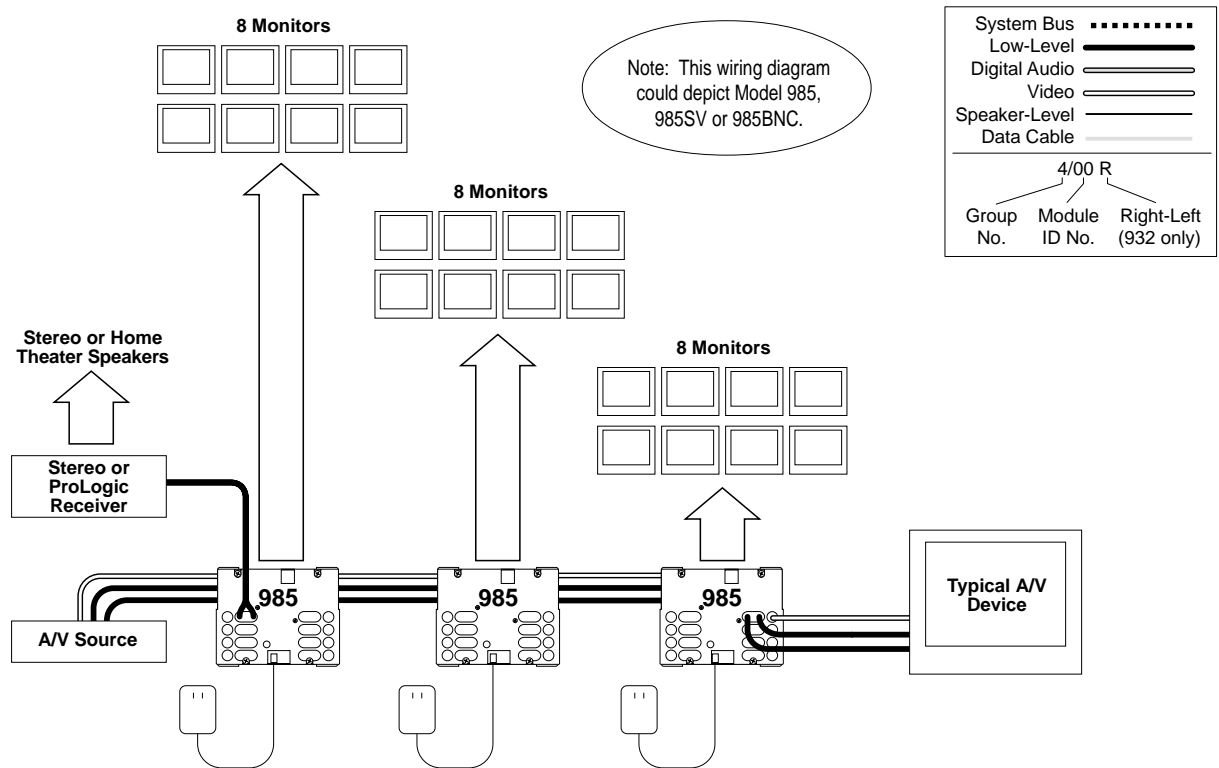

Sample Multiple-Signal Distribution System

- Two Source units provide greater choice of demonstration material.
- Each video monitor's multiple inputs are used to switch the signal.
- Each A/V source requires a separate set of 985 modules.
- To switch from Satellite TV to DVD for a home theater demonstration, push the "A/V 2" button on the TV monitor.
- An output from a 985 could connect to a 955 module in an integrated display, just as the other media players do. The video signal could be routed through the Receiver Group and to a final 985 if desired.

