



# 1805

## Variable Gain Amplifier

## Compact Amplifier with Serial Control

The Audio Authority® 1805 is designed to provide amplification for speakers in retail demonstrations or educational displays. Control volume via RS-232 or RS-485 using custom control devices such as a touch screen or an Audio Authority TouchSelect panel as shown in the example below. For best results use a commercial grade media player such as the Model 1803 High Resolution Audio Player.

### Features:

- Up to 10.5 watts per channel
- Volume may be controlled by RS-232 or RS-485
- Gain adjustment per channel
- Small footprint for easy placement in fixtures

### Example System:

The 1805 sends amplified audio to the Model 1819 switch modules that route audio to the speakers. The 1803 media player's MicroSD card contains the uncompressed audio content and provides the low-level input signal for the 1805 amplifier. The TS09 controls the demonstration system via RS-485.

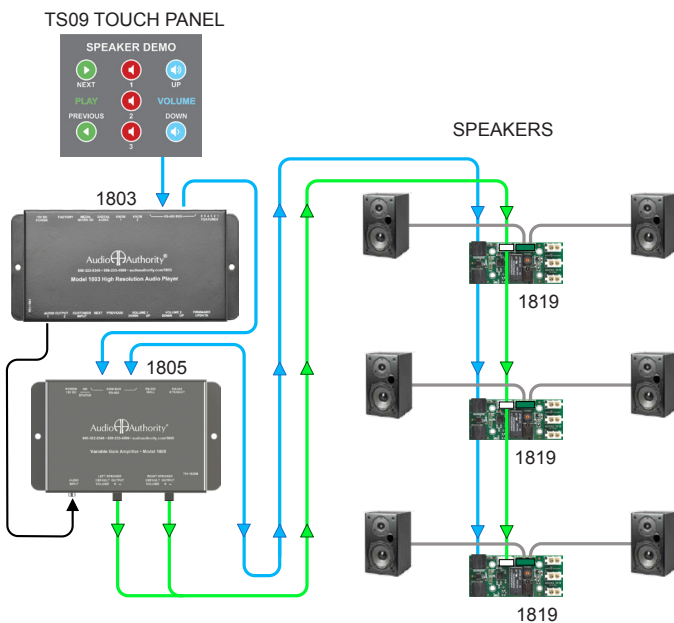

### Specifications

- Dimensions (HxWxD, inches): 3.5 x 5.9 x 1.1
- Power (@ 1% THD+N, 1kHz): 8.5W per channel
- Frequency Response: 20Hz -20kHz (+/- 0.736dB)
- Load Impedance: 8 ohms



The Audio Authority TouchSelect series offers flexible solutions to any interactive challenge - product activation, play/pause, volume control, or multiple track choices. These panels can be linked together with standard Cat 5 cables, and connected to a variety of compatible modules to create a complete demo system.