

Audio  Authority<sup>SM</sup>

***Series 1580***  
*Intercom Systems*

**THE COMPLETE 1-ON-2 SOLUTION**

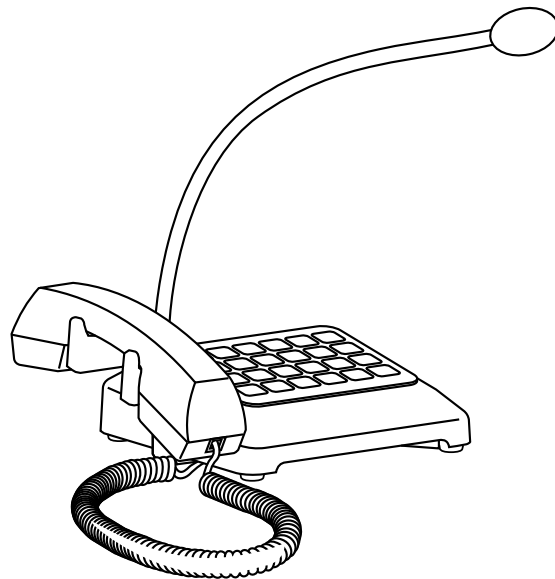

**Installer's Reference Guide**

# *Series 1580*

## *Intercom Systems*

### THE COMPLETE 1-ON-2 SOLUTION

#### **WARNINGS**

- Read these instructions before installing or using this product.
- To reduce the risk of fire or electric shock, do not expose components to rain or moisture (except Model 1585 which is designed for outdoor use).
- This product must be installed by qualified personnel.
- Do not open the cover—there are no user-serviceable parts inside.
- Do not expose this unit to excessive heat.
- Install only in dry, indoor locations.
- Clean the unit only with a dry or slightly dampened soft cloth.

#### **LIABILITY STATEMENT**

Every effort has been made to ensure that this product is free of defects. Audio Authority cannot be held liable for the use of this hardware or any direct or indirect consequential damages arising from its use. It is the responsibility of the user of the hardware to check that it is suitable for his/her requirements and that it is installed correctly. All rights are reserved. No parts of this manual may be reproduced or transmitted by any form or means electronic or mechanical, including photocopying, recording or by any information storage or retrieval system without the written consent of the publisher.

Audio Authority reserves the right to revise any of its hardware and software following its policy to modify and/or improve its products where necessary or desirable.

Audio Authority and the Double-A Symbol are registered trademarks of Audio Authority Corp. Copyright June, 2010. All third party trademarks and copyrights are recognized.



2048 Mercer Road, Lexington, Kentucky 40511-1071 USA

Phone: 859-233-4599 • Fax: 859-233-4510

Customer Toll-Free USA & Canada: 800-322-8346

[www.audioauthority.com](http://www.audioauthority.com) • [support@audioauthority.com](mailto:support@audioauthority.com)

# Installer's Reference Guide

## Contents

<b>Introduction</b>	<b>3</b>
Tools and Supplies	
Configurations	
<b>Audio Installation</b>	<b>3</b>
Customer Station Setup	
System Configuration	
<b>Lane Cable Information</b>	<b>5</b>
Cable Types	
Wiring Notes	
<b>Video Installation</b>	<b>6-8</b>
System Configuration	
Wiring Notes	
Cat 5 Cable Fabrication	
Video Customer Station	
Program Audio/Video	
Traffic Sensors	
<b>Calibration &amp; Testing</b>	<b>9</b>
Calibration	
Self-Setup	
Troubleshooting	
<b>Operation</b>	<b>10</b>
Operator Tips	
Operator Guide	
<b>Advanced Setup</b>	<b>12</b>
1550 Field Setup Display	
Example Configuration	
Parameter Definitions	
<b>Appendix</b>	<b>15</b>
Multi-pair Cable Termination	

## System Configurations

Audio Authority Series 1580 Intercoms enable clear two-way communication in retail service businesses. A system comprised of a Model 1580 Counter Station (without handset) or 1580H (with handset) and a Model 1583 Dual Lane Station with microphones, speakers, etc. Provides a complete 1-on-1 or 1-on-2 audio solution for drive-up and other customer service applications. The 1580 Series is not expandable beyond 1-on-2, and cannot be used with Series 1500 Counter Stations, Lane Stations or Hubs.

One-way or two-way video is easily added by installing a Model 1581 (inbound only) or 1582 (two-way) Counter Video Add-on and a Model 1584 Video Matrix. On the customer side, the 1584 supports Audio Authority Model 1585 Customer Audio/Video Stations or third-party video cameras and monitors.

### Series 1580 System Components

Counter Audio Station	1580
Counter Audio with Handset	1580H
Inbound Video Add-on	1581
Two-way Video Add-on	1582
Dual Lane Station	1583
Video Matrix	1584
Customer Audio/Video Station	1585

### Accessories

Surface-Mount Customer Handset	1540
Flush-Mount Customer Handset	1541
Wireless Counter Headset	1542
Traffic Sensor	1547
Traffic Sensor Adapter	1589
Field Setup LCD	1550
Universal 1-Amp Power Supply	571-013
5-Amp Power Supply for Heated	571-020
Gooseneck Counter Microphone	631-026
Color Chip Kit	761-311
Lane Microphone kit	631-029
Lane Speaker (3 in.)	631-030

### Special Tools and Supplies

- 18mm flare nut wrench for gooseneck mic installation
- Model 1550 Field Setup Display
- Shielded, paired cable for Lane Station (drive-ups)

## Audio Installation with 1580S or 1580HS Kits

The 1580S Kit consists of one Model 1580, one Model 1583, and a 571-013 power supply. To complete the system, the necessary lane microphones, speakers, call button switches, and shielded cable for one or two customer positions or drive-up lanes must be purchased separately. The 1580HS Kit is exactly like the 1580S, but contains a 1580H Counter Station with a handset.

Figures 3 and 4 show the usual wiring method. After plugging in the main components as shown, wire each LANE port of the 1583 Dual Lane Station to its respective microphone, speaker and call button using shielded, paired cable with an overall shield as shown in the Lane Cable section (page 5). Mount the 1583 on the wall under the counter, or in some other nearby location.

Cable from the Lane Station to the speaker, mic, call button, etc. must be shielded, paired cable (see recommended cable types on page 5). Four pair, 18 AWG cable is adequate for most installations. Three-pair cable is sufficient for two-way audio and call functions, but more conductors are needed when pneumatic blower motor operation must be sensed, a traffic sensor is installed, or the dry relay contacts are used.

Whatever cable is used, it must have an **overall foil shield** – the drain wire is connected to the Common (#8) terminal on each Lane station block. **The DRAIN WIRE on the customer end of the cable must be cut off and not connected.** For proper system operation, one of the Lane Common terminals must also be connected to a good ground, such as an electrical box or a metallic structural member, using the green ground wire supplied. This wire may be extended if necessary.

### Audio Counter Station Assembly

Install the supplied “gooseneck” microphone on the 1580 Counter Station by plugging it into the jack at the rear, tightening the hex nut and setting the rubber boot over the nut. If equipped with a handset, plug it into the jack on the bottom of the 1580, push the coil cord into the notch on the bottom edge of the housing, and set the handset on its cradle.

The color chip array under the keypad cover can be rotated to choose between black and red or yellow and red Lane keys. To do that, loosen the 4 small screws at the corners of the keypad cover to remove it and rotate the color chip array. If other than these colors are desired, carefully break out the chip(s) that must be changed and replace them with chips taken from the 12-color chip array (761-311, purchased separately). Replace the keypad cover and carefully replace the screws without overtightening.

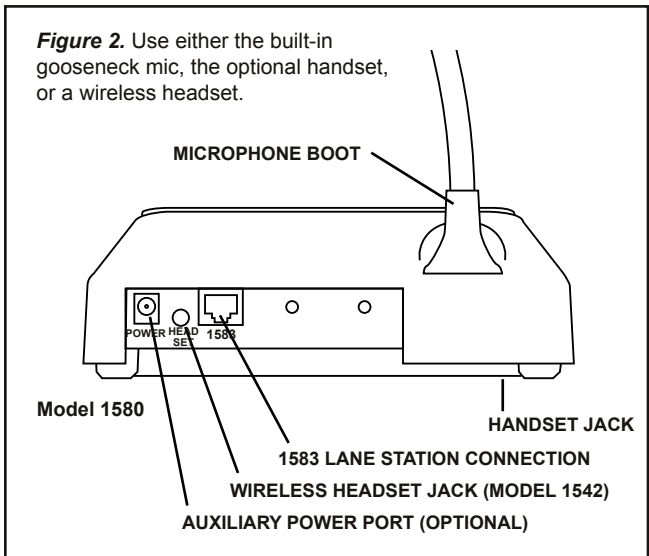
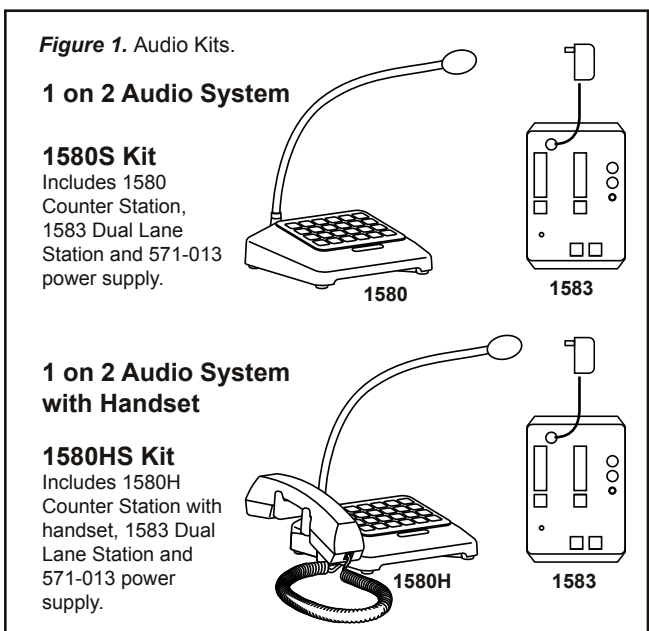

The counter station power port is used only when the 1583 is not near an AC power outlet, or when both counter and lane station must be powered due to excessive distance between them.

**Figure 3.** Typical audio only system with optional handsets installed. Shielded, paired cable is required for lane wiring as shown.

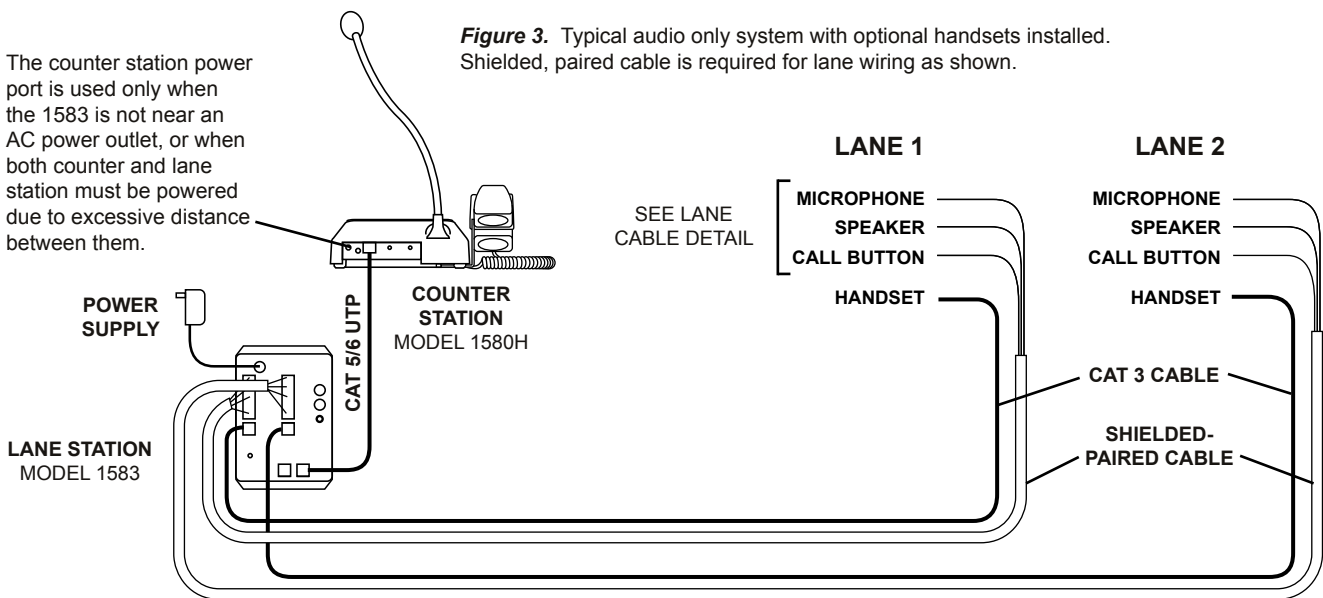

## Lane Cable

Use shielded, paired cable with three to six twisted pairs of conductors (depending on configuration) to connect the Model 1583 Dual Lane Station to the lane microphone, speaker, call button, etc. Use one pair each for microphone and speaker, and the remaining conductors for other functions sharing a common ground (Figures 3 and 4). See page 15 for more diagrams.

### 1583 Wiring Notes

- Always use one twisted pair for microphone, and one for speaker to maintain audio quality.
- Connect the 1583 Common terminal (of one lane) to a reliable ground.
- Connect the Drain Wire to the 1583 Common terminal, and trim at the other end.
- N.O. (Normally Open) Contacts are used for any device such as a door latch or solenoid that must be operated from the Counter Station. See page 10.
- Handset wiring details are shown on page 15.

### Recommended Lane Device Cables for 1583

Use these shielded, paired cables for lane audio and other devices as shown in Figure 3.

22 GAUGE (50 feet maximum)			
BRAND	3 PAIRS	4 PAIRS	6 PAIRS
Belden	5542FE	5543FE	5545FE
General Cable	C0551A	C0552A	C0553A
Alpha Wire	6418	6419	6420
Consolidated	6703-CL	6704-CL	6706-CL
18 GAUGE (125 feet maximum)			
Belden	5342FE	5343FE	5345FE
General Cable	C0561A	C0562A	C0563A
Alpha Wire	6428	6429	6430
Consolidated	6753-CL	----	6756-CL
16 GAUGE (250 feet maximum)			
Belden	1528A	1584A	----

Figure 4. Shielded, paired cable (four-pair in this example) for connecting Lane Station terminals to audio and other lane devices.

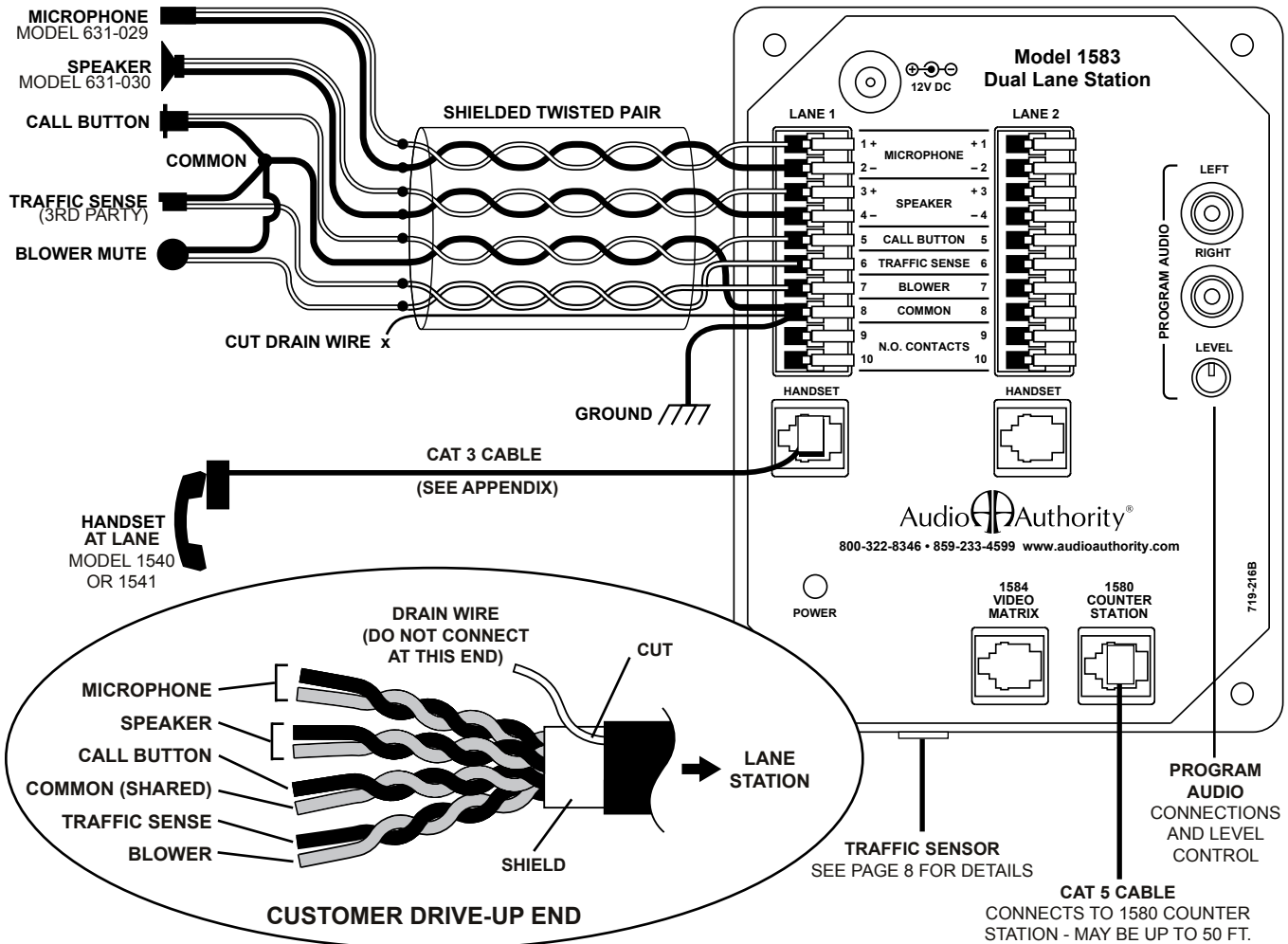

## Video Installation with 1581S or 1582S Kits

Video may be added to an audio-only system using these kits, which include a Model 1581 (one-way video) or 1582 (two-way video), a Model 1584 video matrix and a 1-amp power supply. A Model 1585 Customer A/V Station or third-party video cameras and monitors are purchased separately, along with the necessary Cat 5e/6 or coaxial connecting cable.

Assemble the 1581 or 1582 Video Add-on to the rear of the 1580 Counter Station base using the two screws furnished and tighten them securely. Loosen the adjustment knobs on the support column to adjust the angle and height of the video head.

Mount the 1584 on the wall near the 1583 Dual Lane Station and connect it to the 1581 or 1582 Counter Video unit and the 1583. Connect the remaining lane video cameras, monitors, and/or Model 1585 Customer Stations to their respective ports on the 1584. When preparing Category 5 cable for Model 1585 video connections, be careful to correctly assign the 8 wires to each modular plug using EIA 568B specifications. See the wiring guide on page 15.

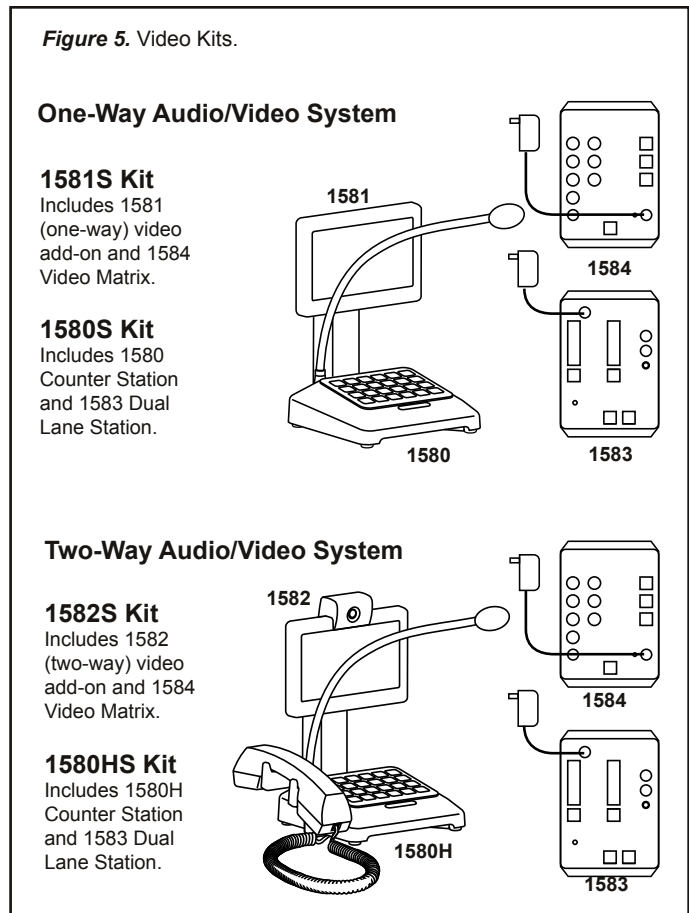

**Figure 6.** Video configuration with handset on Lane 2. See page 15 for handset cable termination. Always use shielded, paired cable for lane audio, call button, etc.

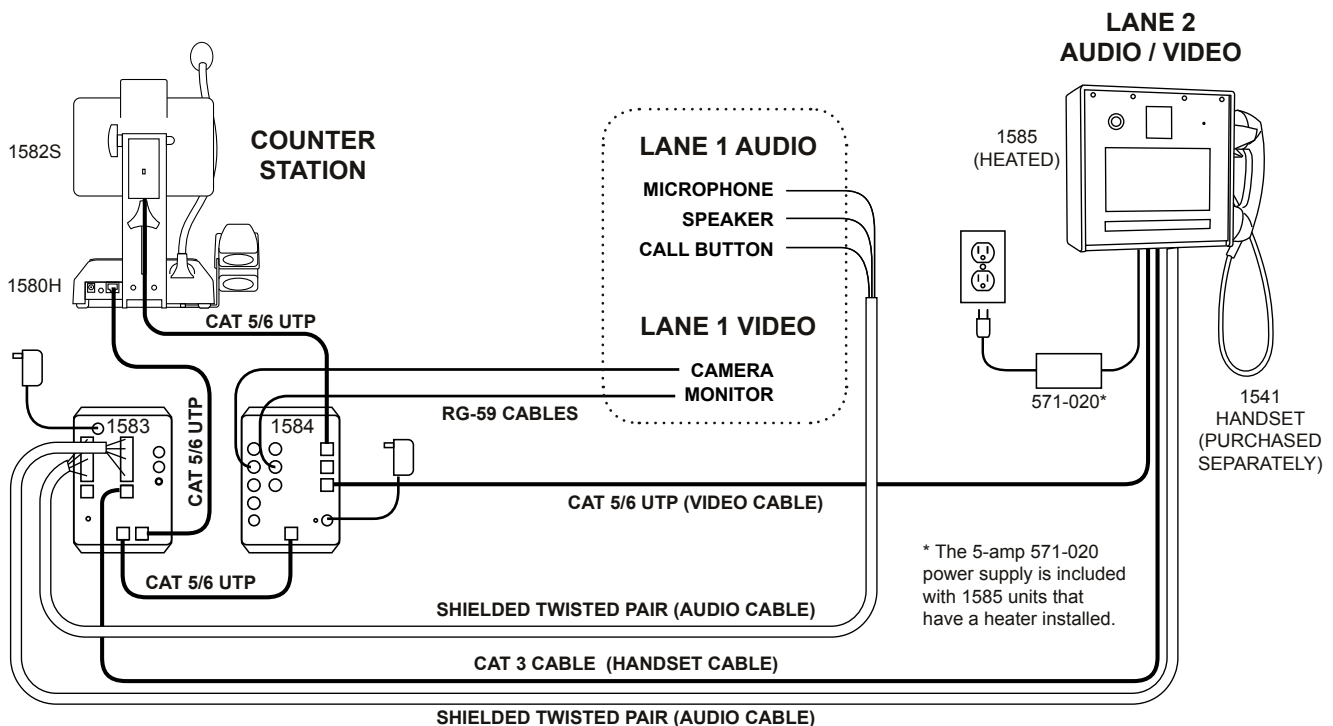

## Lane Video Wiring

- See page 15 for Cat 5 cable termination instructions.
- To connect individual monitor and camera use RG-59 with BNC connectors.
- 1585 Customer A/V Station: connect Cat 5e/6 cable to modular coupler as shown, then tuck inside housing.
- Connect a wide view camera if desired. By default this camera's output is visible in the camera rotation sequence when no lane is selected. The system can also be set up to show this camera on the Counter Station monitor at all times. See Advanced Setup on page 12.
- Program video (if used) requires composite video source. See page 8 for details.

**Figure 7.** Model 1584 Video Matrix wiring.

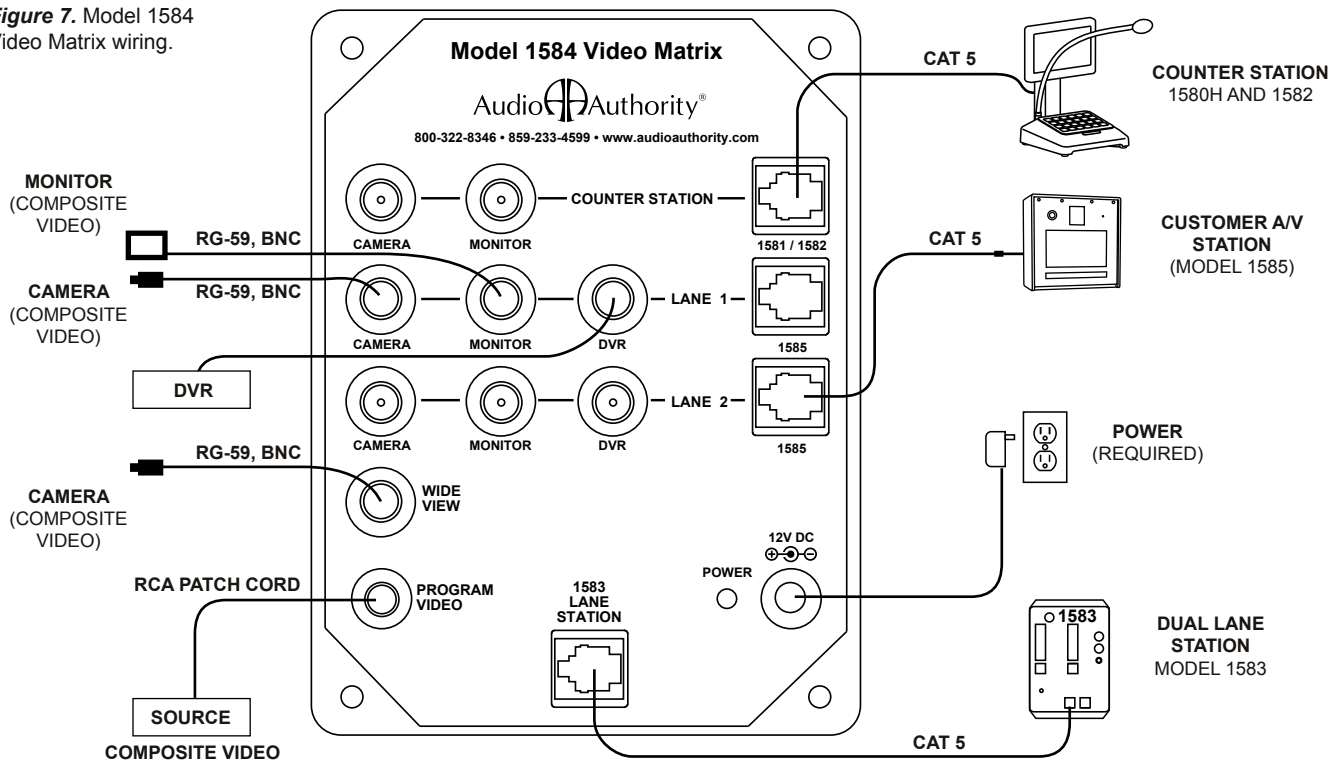

## Model 1585 Customer Station Installation

Model 1585 Customer Stations accept a Category 5 cable from a 1584 Video Matrix and a multi-paired cable from a 1583 Dual Lane Station. Connect pairs of lane cable conductors to their respective microphone, speaker, and call button positions on the terminal block inside the 1585. Additional terminals are provided in the 1585 for control functions supported by Model 1583.

If a Model 1541 armored handset is being added to the Model 1585, remove the large knockout on the right side panel of the 1585 enclosure, mount the 1541 with the fasteners provided and run a Cat 3 modular cable from the 1541 to the respective Handset port on the 1583 Dual Lane Station.

**Figure 8.** Model 1585 Customer A/V Station.

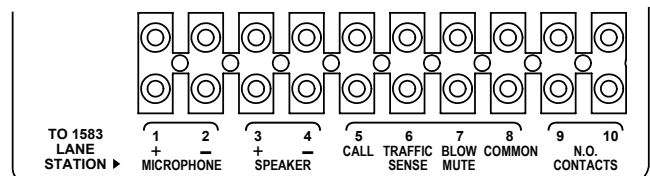
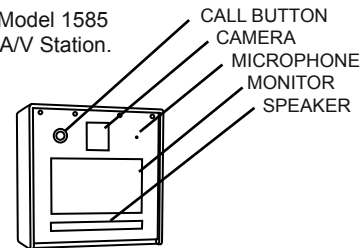

**Figure 9.** Terminal block inside 1585 for connecting 1583 shielded cable devices. Video display, camera and handset are wired separately.

## Program Audio/Video Connection

If audio or video program content will be playing at the customer positions when lane stations are on HOLD or idle, plug the source player or PC into the Program Input ports on the 1583 and 1584, respectively. Program audio level may be manually adjusted on the 1583. One lane's program audio may be turned off during idle periods (still heard while on HOLD) using the 1550 Program Audio Abate setting (see page 14).

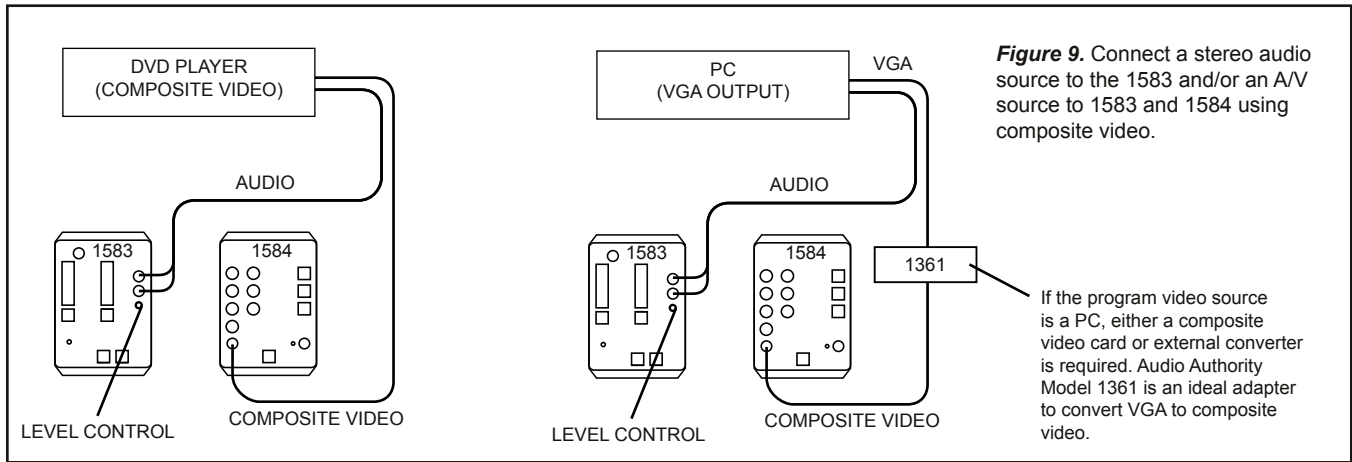

## Using Third Party Traffic Sensors

The 1583 Dual Lane Station provides a contact for third party traffic sensing devices (Pin 6). Connect the device to pin 6 and the common ground wire (Pin 8).

3RD PARTY TRAFFIC SENSOR +  
-

## Using Model 1547 Traffic Sensors

The 1583 Dual Lane Station provides a connection for Audio Authority's Model 1547 traffic sensors. One or two 1547 sensors may be connected to the 1583 *flash port*, located on the end panel, via the 1589 adapter as shown. When a vehicle triggers the 1547, the Counter Station generates a call tone for the corresponding lane to alert the operator. To extend a traffic sensor, use an in-line coupler and a length of Cat 5 cable as shown.

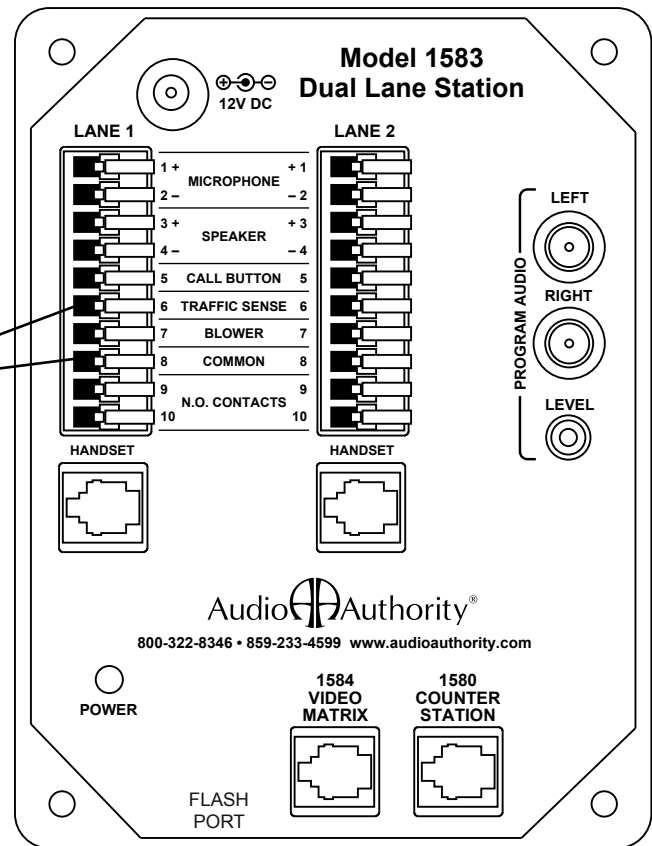
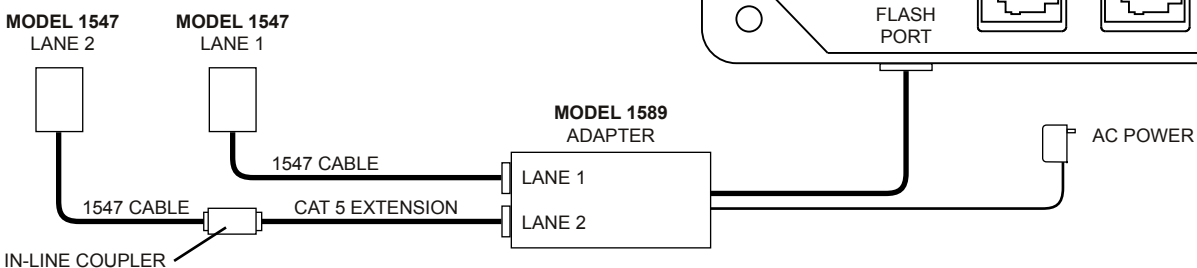



## Basic Calibration and Testing

Check the following locations for successful power-up and connections, indicated as follows:

- 1580/1580H Counter Station: After boot-up, all lights are dark until a lane or Privacy mode is selected.
- 1583 Dual Lane Station: Normal = rapidly flashing green light (lane selected = solid green light)
- 1584 Video Matrix: Normal = rapidly flashing green light (lane selected = solid green light)
- Check the voice channels by selecting each lane and speaking with an assistant at the customer locations. Adjust Lane Microphone and Speaker gains using the Model 1550 Field Setup Display (see page 12 and 13).

### Video systems only:

- Touch Camera Up and Down (while lane is selected) to check Lane Camera tilt.
- Touch Mirror to view Counter Station camera image (operator view).
- Touch and hold Mirror for three seconds to view program video and hear program audio.

### Self-Setup Mode Adjustments

Some operating features are adjusted using the 1580's self-setup mode (see below). Advanced setup features require the 1550 Field Setup Display. See page 12 for advanced setup.

Touch and hold the Setup key (without a 1550 connected). The lights next to Camera Up/Down and Volume Up/Down keys illuminate.

- Touch Camera Up and Down to select one of 16 ringtones.
- Touch Volume Up and Down to set ring volume.
- Select Privacy (light comes on) and touch Volume Up or Down to set handset and/or wireless headset volume.
- If further handset transmit or receive volume adjustment is needed, use TX and RX knobs on the underside of the 1580 Counter Station (Figure 11).

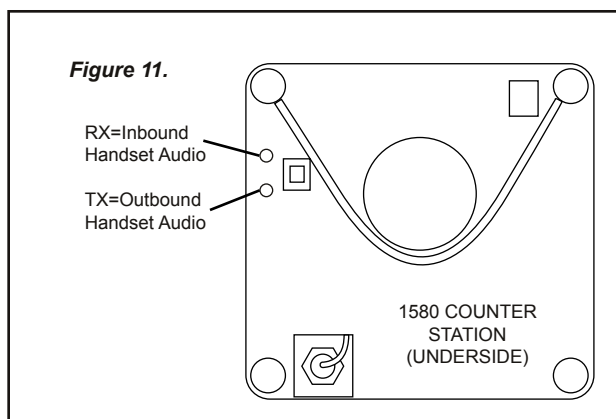

## Troubleshooting Tips

- **ALWAYS** test Cat 5 or other UTP cables with a cable tester – even pre-made cables
- In case of unexpected performance, restore system defaults to rule out incorrect system parameters
- 1583 and 1584 power lights flashing rapidly – indicates normal connection (solid on indicates a lane is selected)
- 1583 or 1584 power light blinks every three seconds – Indicates problem with system interconnects

### Acoustical Coupling (Feedback)

- Increase separation of lane microphone and speaker
- Isolate lane microphone and speaker with sound-damping barrier (i.e. foam rubber)
- Mount lane speaker and microphone on separate surfaces or adjust their mounting angles
- Adjust inbound, outbound or open loop gain levels (requires 1550)

### Audible Hum

- Connect 1583 terminal #8 to a good ground

### The Deal Drawer Doesn't Sound Right

- Fill hollow cavities in the deal drawer with foam rubber sheets or blocks
- Do not rest Counter Station directly on deal drawer

### No Inbound / Outbound Video or Poor Video Quality

- Check Cat 5 cables - consistently use EIA 568A or EIA 568B standard cable termination (see page 15)
- Check video connectors on 1584 and source if field-terminated coax cables are used.

### Lane Keys Don't Respond

- Keys not assigned to Counter Station – reassign keys or restore factory defaults in configuration menu

### Counter Station Lights Remain in 'Burn in' Pattern

- Check Cat 5 cable - consistently use EIA 568A or EIA 568B standard cable termination (see page 15)

### Lane Microphone Doesn't Work

- Ensure microphone is electret condenser type
- Check microphone wiring for correct polarity
- Check Cat 5 cables - consistently use EIA 568A or EIA 568B standard cable termination (see page 15)
- Ensure Cat 5 cables are connected to correct ports

### Wind Noise

Wind noise can often be eliminated by putting a small plug of 3M Scotchbrite™ material in the microphone opening. The Audio Authority® lane microphone has a special foam surround; for optimum results, use Audio Authority microphones (631-029) and speakers (631-030).

## Operation

The 1580 Series Intercom is operated via touch-sensitive keys on the Counter Station keypad, shown below. Tasks such as answering a customer call, ending a call, and putting a customer on HOLD are shown on the Operator Guide (page 11) which should be kept near the Counter Station for reference.

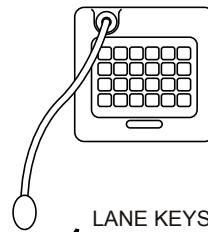

**Figure 12.** Counter Station Keypad.

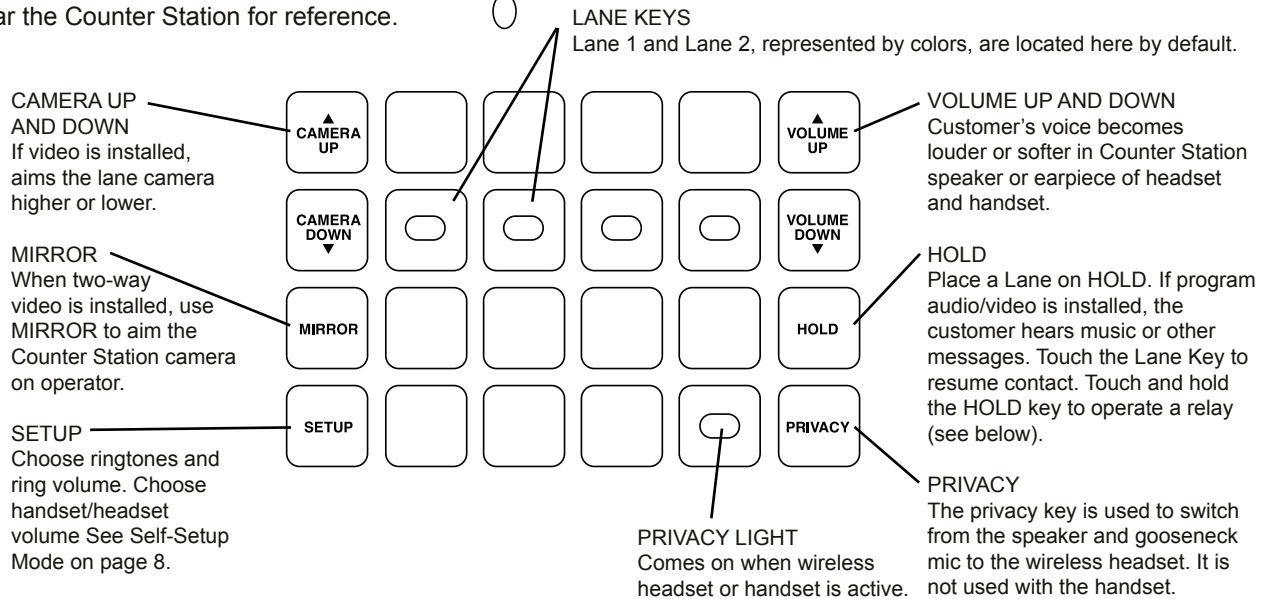

## Operating Remote Devices

The 1580 can be wired to operate a latch or door in a remote location via the keypad. The system can be set up to be operated in two different ways; consult your technical support provider for details.

- Option 1: Any time the lane is selected the remote device is active (e.g. a door opens).
- Option 2: When a lane is active, the operator touches and holds the HOLD key to activate the device (e.g. hold the door open). The HOLD key operates normally when touched briefly.

## Using a Wireless Headset or Handset

The 1580 and 1580H switches between the built-in speaker and gooseneck microphone, the 1580H handset, and an optional wireless headset. Some examples of using these communication methods are listed below. Always deactivate the wireless headset between customer interactions to increase battery life.

### Answering a Call

- Speaker/gooseneck mic: Touch the rapidly flashing lane key.
- Handset: Pick up the handset. The first calling lane is automatically selected.
- Wireless headset: Activate the headset, touch PRIVACY and select the flashing lane. If the headset is the preferred method, leave PRIVACY on.

### Putting a Call on HOLD

- Speaker/gooseneck mic: Touch the lane key.
- Handset: Hang up the handset. The calling lane is automatically placed on HOLD.
- Wireless headset: Touch HOLD.

### Picking Up a Call from HOLD

- Speaker/gooseneck mic: Touch the blinking lane key.
- Handset: Touch the blinking lane key and pick up the handset.
- Wireless headset: If PRIVACY is already on, activate the headset and select the blinking lane key.

# OPERATOR GUIDE

## Audio Authority Series 1580 Counter Station

### Green Lane Key Lights

**Flashing** (*Rapidly*) = Customer calling

**On** = Customer in 2-way contact

**Blinking** (*Slowly*) = Customer placed on HOLD

### Operation Tips

- Speak naturally into the microphone at a distance of about two inches
- Touch keys with the pad of your finger
- Video: Press MIRROR to center your image in the lane display

### Counter Station

- To contact a customer calling ..... Touch LANE key or pick up handset (1580H only)
- To place a customer on HOLD ..... Touch the HOLD key or hang up handset (light blinks)
- To contact a customer on hold ..... Touch the LANE key
- To end contact with customer ..... Touch the active LANE key
- To cancel hold and end contact ..... Touch the LANE key twice
- To talk over a customer ..... Touch and hold the active LANE key
- To adjust incoming volume ..... Touch VOLUME UP or VOLUME DOWN key
- To enter/exit PRIVACY (headset) mode ..... Touch the PRIVACY key
- To activate remote relay ..... Touch and hold the HOLD key (30 seconds max)

### Wireless Headset

- To use a wireless headset, touch PRIVACY, activate the headset, and select the flashing lane key
- If the headset is the preferred method, leave PRIVACY *on*
- To increase headset battery life, deactivate the headset between customer interactions

### Handset

- To answer a call, pick up the handset, the first calling lane is automatically selected
- To place a customer on HOLD, hang up the handset
- To speak to a customer on HOLD, pick up the handset and touch the lane key

### Counter Station Video

- To adjust outside camera on selected lane ..... Touch CAMERA UP or CAMERA DOWN key
- To view yourself (to aim camera) ..... Touch MIRROR key (30 second time-out)
- To view outgoing video program ..... Hold MIRROR key 3 seconds (no lane selected)
- To pause lane camera scrolling ..... Touch HOLD key (no lane selected)
- To view next lane camera ..... Touch CAMERA UP key (no lane selected)
- To view previous lane camera ..... Touch CAMERA DOWN key (no lane selected)

### Adjust Ringtones and Ringer Volume

- Touch and hold the SETUP key until lights next to CAMERA and VOLUME keys blink
- Touch CAMERA UP and DOWN to select one of 16 ringtones
- Touch VOLUME UP and DOWN to set ringer volume

### Adjust Counter Station Handset Volume (1580H)

- In SETUP MODE, touch PRIVACY and press VOLUME UP or DOWN
- If further handset transmit or receive volume adjustment is needed, contact your technical support provider



2048 Mercer Road, Lexington, Kentucky 40511-1071  
Phone: 859-233-4599 • Fax: 859-233-4510  
Customer Toll-Free USA & Canada: 800-322-8346  
www.audioauthority.com • support@audioauthority.com

752-601  
2/10

# Advanced Calibration and Setup

## Using the 1550 Field Setup Display

The Model 1550 is a device that displays and enables the advanced setup menus and settings for Series 1500/1580 Intercom Systems. (Touching SETUP without the 1550 activates basic SETUP MODE.) Connect the 1550 Field Setup Display to the RJ-45 jack on the underside of the Counter Station. (The jack is at an angle, located near the right front edge of the Counter Station.) Upon connection, the 1550 displays "SERIES 1500 EQUIPMENT CALIBRATION PLATFORM".

Figure 13. 1550 Field Setup Display

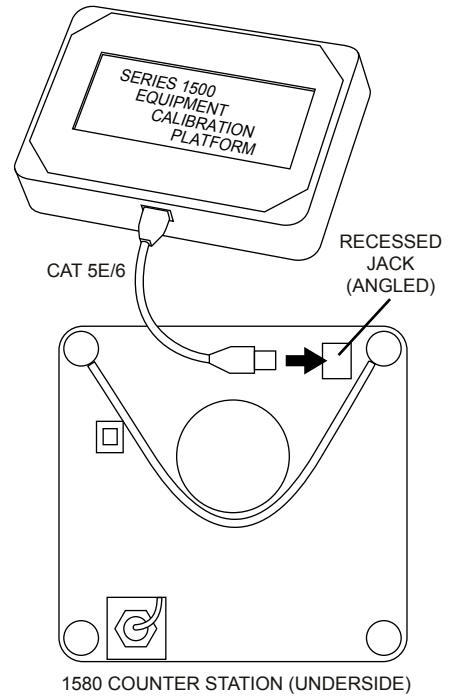
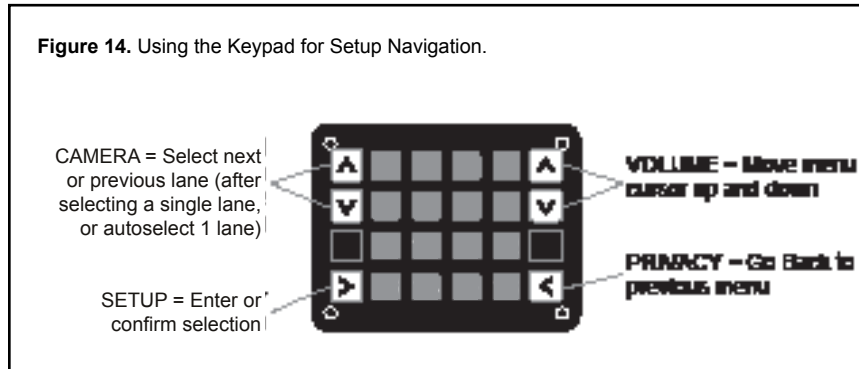

Figure 14. Using the Keypad for Setup Navigation.



## Setup Mode Operation

- Hold the SETUP key on the Counter Station for one second to enter Setup Mode. The 1550 displays the top level of the menu.
- To navigate the menus, use the VOLUME UP and VOLUME DOWN keys to move the cursor.
- Use SETUP to enter a submenu or confirm a selection, and PRIVACY to save and exit a submenu.
- Any changes you make are recorded as you exit each menu. When you exit Setup Mode, you must choose to either save all changes and exit or exit without saving.
- If you need to re-enter Setup Mode, simply touch SETUP for 1 second.

## Setup Menu Map

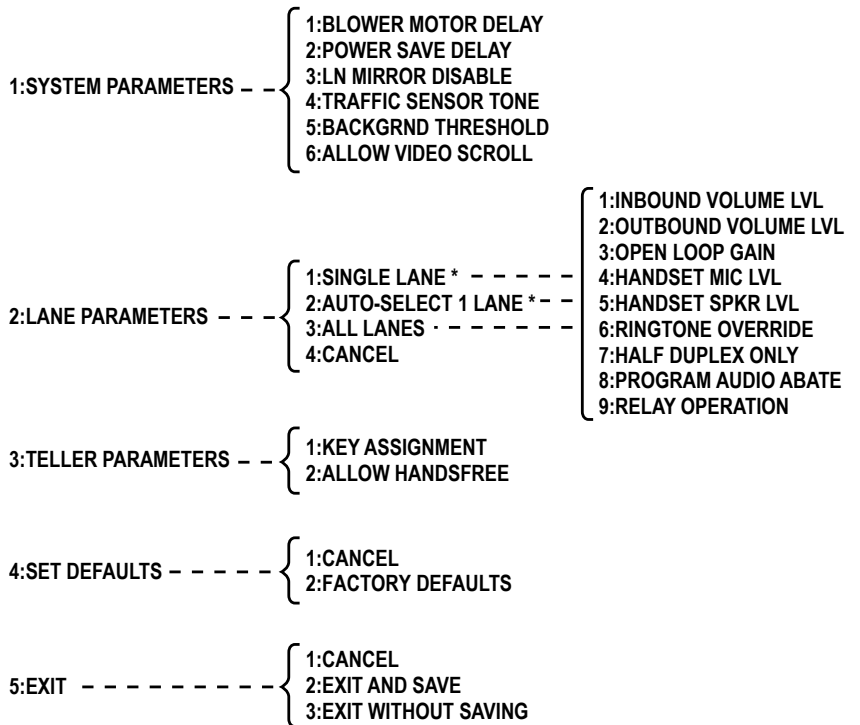

\* LANE PARAMETERS: There is a lane selection menu between the menus pictured. Select SINGLE LANE, or AUTO-SELECT 1 LANE and touch SETUP. Select the desired lane, and touch SETUP to make adjustments to that lane. Touch PRIVACY to save and exit.

## Advanced Configuration Example

To enter the configuration menu, connect a 1550 Field Setup Display to the underside of the 1580 Counter Station, then touch and hold the SETUP key for one second.

### Adjust Audio Levels

1. Select 2:LANE PARAMETERS
2. Select 2:AUTO-SELECT 1 LANE
3. Select Lane 1 or 2.
3. Touch SETUP to confirm
  - a. Set inbound audio level
    - i. Select 1:INBOUND VOLUME LVL
    - ii. Use VOLUME keys to raise or lower inbound volume
    - iii. Touch PRIVACY key to return
  - b. Set outbound audio level
    - i. Select 2:OUTBOUND VOLUME LVL
    - ii. Use VOLUME keys to raise or lower outbound volume
    - iii. Touch PRIVACY key to return
  - c. Adjust open loop gain
    - i. Select 3:OPEN LOOP GAIN
    - ii. Use VOLUME keys to raise or lower open loop gain
    - iii. Touch PRIVACY key to return
  - d. Touch CAMERA UP/DOWN keys at any time to adjust next/previous lane station

### Configure Key Assignment

1. Select 3:TELLER PARAMETERS
2. Touch SETUP
3. Select 1:KEY ASSIGNMENT
  - a. Use VOLUME keys to select lane to be assigned
  - b. Touch any lane key to assign selected lane to that key

### Exit Setup

- a. Hold SETUP for one second to jump to EXIT menu at any time
- b. Select 2: EXIT AND SAVE
- c. Touch SETUP to exit

## Setup Definitions

BLOWER MOTOR DELAY	When enabled, and blower mute connections are installed, this is the period between disengagement of the blower and microphone audio un-mute.
POWER SAVE DELAY	When enabled, this is the length of time the system must be idle before entering Power Save (LCD sleep).
LANE MIRROR DISABLE	OFF = idle Lane Stations display their own camera output. ON = idle Lane Stations DO NOT display their own camera output. Customers see a blank screen or program video, if installed.
TRAFFIC SENSOR TONE	Touch a key to select a unique ringtone for all traffic sensor events. 0 = no ringtone, 1 = use Lane Station Ringtone Override setting.
BACKGRND THRESHOLD	Adjustment for level of background audio that is rejected by Counter Station microphone. 0 = no rejection.
ALLOW VIDEO SCROLL	Counter Station monitor rotates between lane camera views and wide angle camera when no lane is active.
SINGLE LANE	Use this mode to configure lane without live audio. Useful when lanes are in use or audio is not required for adjustments.
AUTO-SELECT 1 LANE	Use this mode to configure lane with live audio (using an assistant at the Lane Station). Useful for adjusting inbound and outbound audio levels.
INBOUND VOLUME LVL	Adjust volume level of customer's voice heard at the Counter Station.
OUTBOUND VOLUME LVL	Adjust volume level of operator's voice heard at the Lane Station.
OPEN LOOP GAIN	Adjustment for adapting to different acoustic environments. Lower this setting for Lane Station acoustical environments with too much microphone and speaker coupling. Increase this setting to hear more of the customer while operator is talking.
HANDSET MIC LVL	Inbound handset volume level adjustment (customer's voice).
HANDSET SPKR LVL	Outbound handset volume level adjustment (operator's voice).
RINGTONE OVERRIDE	Touch a key to select a unique ringtone for the selected Lane Station(s). 1 = no override (plays the ringtone set by the Counter Station). All other keys represent unique ring tones which override any Counter Station settings.
HALF DUPLEX ONLY	Enables 'push-to-talk' operation, useful for high background noise locations.
PGM AUDIO ABATE	ON = Program Audio heard ONLY when lane is <i>on hold</i> . OFF = Program Audio heard when lane is <i>idle</i> OR <i>on hold</i>
RELAY OPERATION	Allows configuration of 1583 relay contacts (terminal block positions 9 & 10). The contacts can be set to close using the HOLD key (touch and hold operates the relay), or while the lane is selected. (See Operator Guide for HOLD key operation details.)
KEY ASSIGNMENT	This menu enables lane selection keys to be redefined in any configuration desired. First select the lane number to be assigned using the VOLUME keys. Then touch the key to be assigned to that lane.
FIRMWARE UPGRADE	This menu is used to update the firmware of system components. Call Audio Authority Technical Support for details.

## Appendix: Multi-Pair Cable Termination

### Lane Wiring, Five Devices

Use 4-pair shielded, paired cable for up to five devices. See page 5 to determine the required gauge. Always use one pair for mic (+ / -) and speaker (+ / -). The other devices share a common.

**ALWAYS TRIM THE DRAIN WIRE AT THIS END.**

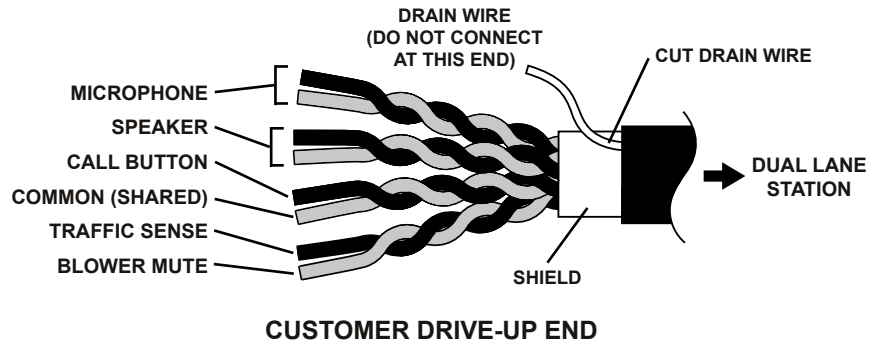

### Lane Wiring, Three Devices

Use 3-pair shielded, paired cable for up to three devices. See page 4 to determine the required gauge. Always use one pair for mic (+ / -) and speaker (+ / -). The other pair can be used for blower mute, traffic sensor, or call button.

**ALWAYS TRIM THE DRAIN WIRE AT THIS END.**

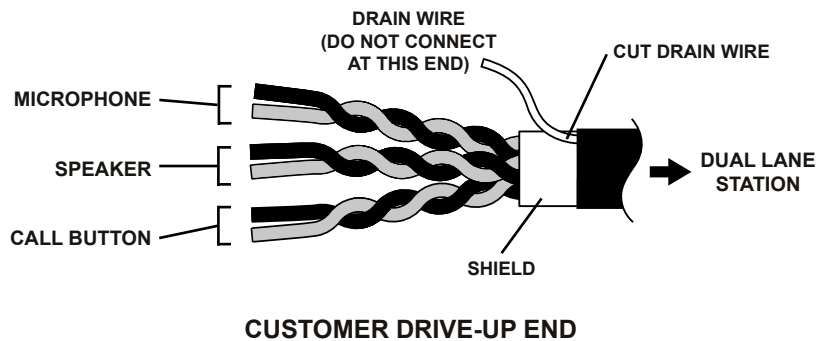

### Cat 3 Cable Fabrication

#### (For 1540 or 1541 Lane Handset)

For customer handsets use 3-pair Category 3 cable. Terminate at each end with an RJ-12 plug (sometimes referred to as RJ-25). One end is terminated opposite (mirror image) to the other.

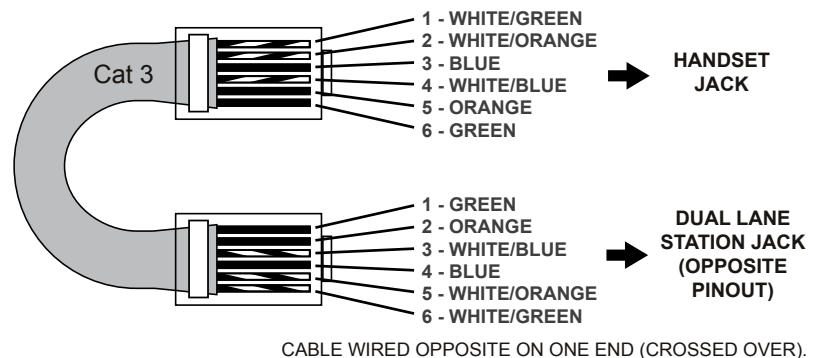

### Cat 5 Cable Fabrication

Cat 5e or Cat 6 is UTP (Unshielded Twisted Pair) cable that can be used to connect Series 1580 components except for locations where shielded twisted-pair cable is required.

Terminate the ends of each Cat 5e/6 cable with RJ-45 modular plugs using the EIA 568B pinout (paired 1-2, 3-6, 4-5, and 7-8). Pre-made network cables may also be used for shorter runs. **TEST** all cables (including pre-made) with a network cable tester.

RJ-45 plug with pins facing up and clip facing away.

Pin 1

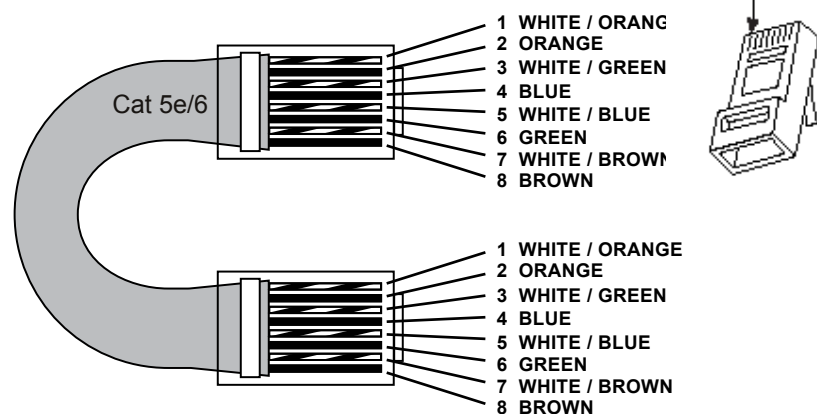



2048 Mercer Road, Lexington, Kentucky 40511-1071 USA  
Phone: 859-233-4599 • Fax: 859-233-4510  
Customer Toll-Free USA & Canada: 800-322-8346  
[www.audioauthority.com](http://www.audioauthority.com) • [support@audioauthority.com](mailto:support@audioauthority.com)