

# *Access*<sup>TM</sup>

## Demonstration Network

### Home Audio and Video System Installation Manual



Audio  Authority<sup>®</sup>



# Contents

<b>Orientation</b>	Introduction.....	4
	How the Access™ System Works.....	5
	Access™ System Components .....	6
<b>Planning</b>	Single Product Group Switching System.....	8
	Multi-Component 2-Channel Switching.....	10
	Home Theater Switching System.....	12
	Video Distribution System .....	14
	Adding Control Interfaces.....	14
	Preparation.....	15
<b>Installation</b>	Addressing .....	15
	Install the System Hardware .....	18
	Install the Bus Cables.....	18
	Check Your Work to This Point.....	21
	Installing a Control Method.....	23
	Installing Remote Switches .....	25
	Testing System Function .....	26
	Demo Product Installation .....	28
	User Tips .....	30
<b>Reference</b>	Appendix A: Sample Systems .....	34
	Appendix B: Product Connection Diagrams.....	38
	Definition of Terms.....	46
	Access™ Warranty.....	48
	Index.....	49

The software imbedded within the Access System is not sold, but rather licensed for this product specific use. The original purchaser is licensed to use this software in this product and this application only. Under this license, the software may not be reproduced, copied, disassembled, distributed by any means, licensed, rented, sold, or in any way revealed to or used by a third party.

The words "Audio Authority" in any font, the Audio Authority logo, and the "double-A" symbol, are registered trademarks of Audio Authority Corporation. Access Demonstration Network, Access, AutoDamping, SPL Auto Limiting, TheftAlert, Access, and SilenTouch are trademarks of Audio Authority Corporation.

Dolby is a trademark of Dolby Laboratories, Incorporated. HDMI, the HDMI logo and High-Definition Multimedia Interface are trademarks or registered trademarks of HDMI Licensing LLC. Toslink is a trademark of Toshiba America.



## Orientation

This manual is provided as a framework to help you successfully install your Access System, test its operation, and then use the system to demonstrate and sell your merchandise. This manual covers the proper installation of the switching system hardware only (if your system includes a 903i Comparator touchscreen interface or 906 Control Panel, please refer to the separate User Guide provided with your control panel for operation instructions).



**Please read and follow these instructions carefully.** If you have any difficulties during the installation, don't hesitate to call us for assistance! We're open Monday through Friday from 8:30 AM until 5:00 PM, Eastern Time. Also check our website for diagrams and tips: [audioauthority.com/access\\_tips](http://audioauthority.com/access_tips).

## Introduction

The Access™ series of demonstration system modules provides a plug-in solution for home, portable audio and car audio switching systems in retail display environments. This second generation of the highly capable, industry-acclaimed Access™ System modules offers many new features and benefits:

- Access offers a compact module to fit each kind of product, compared with a patchwork of printed circuit boards.
- Modules are protected by attractive and rugged steel covers.
- Expansion, when needed, is done by directly “docking” Expander modules.
- Comprehensive control panels with automated demonstration features.
- Single product group control panel for soundbars, in-wall speaker displays, or any product category.
- Your choice of button-per-product, central control panel/third party touchscreen, or any combination of user interface.
- Sophisticated SilenTouch™ interval muting for quiet switching.
- Capacity for hundreds of products.

All of these features make it easy to design the demonstration system that fits your specific merchandising needs. Your Account Manager and our Application Engineering staff can assist you in selecting and configuring the appropriate Access™ modules to build the ideal system for you.

## What is the Access™ System?

The Access™ System is a network of intelligent modules including product selectors, control modules, and signal expander modules. These modules communicate with each other via the “system bus”, allowing you to construct and control the exact demonstration system configuration you desire from the sources, receiver/amplifiers, speakers, subwoofers and video monitors in your display. The modular architecture allows the switching modules to be located near the actual products on display creating a “distributed switching network.” The products are connected to the modules rather than being wired to one central point, simplifying installation. Selected product signals are then sent across the network through “buses” that interconnect the modules

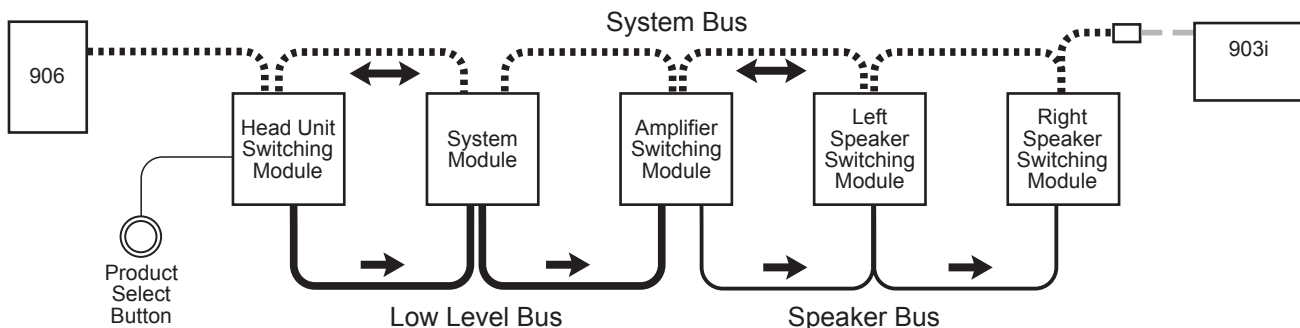

**Figure 1.** Basic overview of the Access Demonstration System

## Buses

Signals are passed between modules through “buses,” which are nothing more than cables that go from module to module to module, connecting them into functional groups within the system’s architecture.

The System Bus connects all switching and system modules, allowing them to send messages to each other, controlled by the addresses that are set by the installer. These signals instruct the modules to select the inputs/outputs of a particular unit, such as a source or receiver. Expander modules are not connected directly to the System Bus. Each expander receives its instruction from the main switch module to which it is attached.

Signal Buses carry audio signals, either low-level (source low-level output, for example), high-level signals (amplifier output), or video signals.

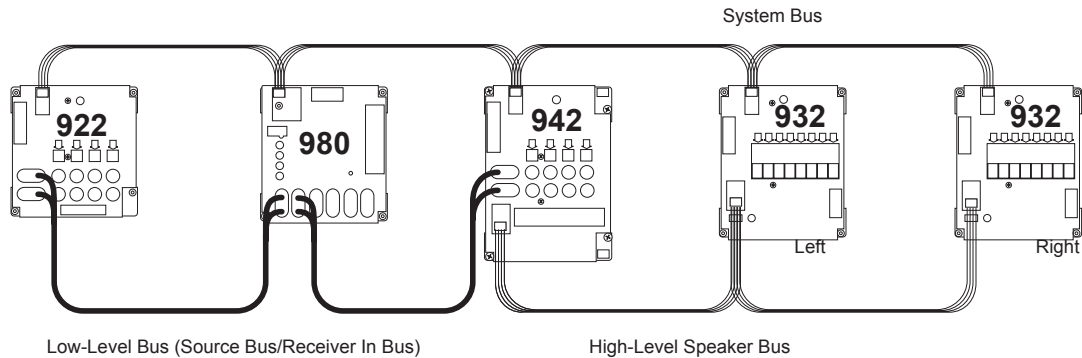

**Figure 2.** Basic bus examples in a simple demonstration system

## How the Access™ System Works

When a product is selected for demonstration, signals are sent through a network of buses between switching modules to activate that particular product position.

### Selecting Products in the Access™ System

Products can be selected in a system in different ways that can all be combined into a single system, if desired. You may select products in the following ways or a combination of these methods:



**Figure 3.**  
By pressing a Product Select Button (PSB) connected to a switching module.



**Figure 4.**  
By using a 906 control panel to select products in a single group.



**Figure 5.**  
By using a 903i Comparator touchscreen to select products in multiple groups.

# Access™ User Interfaces Control Panels

## 903i Comparator Touchscreen

The Model 903i Comparator is a 10 inch capacitive touchscreen that connects to any Access switching system, providing an easy way to select products and compare systems.

- Multiple Product Group cards
- Swipe through product icons, up to 99 products per group
- Compare Systems mode for easy A/B system comparison
- PIN protection for setup features
- Lock feature disables the comparator, unlock with PIN

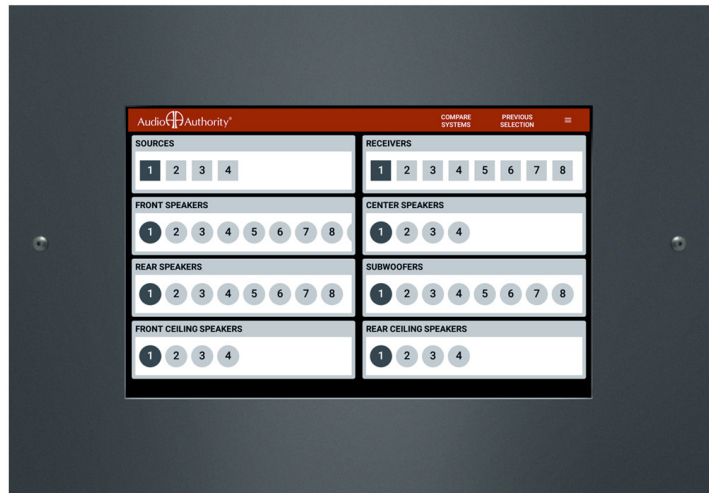

Figure 6. The 903i Comparator with bezel.

## 906 Control Panel

Perfect for DVD displays, speaker walls, or home theater package systems. The 906 Control Panel selects products from one Product Group, using a rotary encoder knob, and displays the selected product number in the LCD window. Use the Select Previous button to make instantaneous comparisons between products. Two 906 Control Panels may be used in one system, one 906 for each Product Group.



Figure 7. 906 single product group control panel.

## Product Select Buttons

A product select button is a momentary switch, usually with an LED to indicate when a product is selected. Each button has a four-conductor cable connecting the button to the switch module (See page 25 if using legacy two-conductor buttons.) Audio Authority carries several button styles and colors, check with your Account Manager for colors and availability.

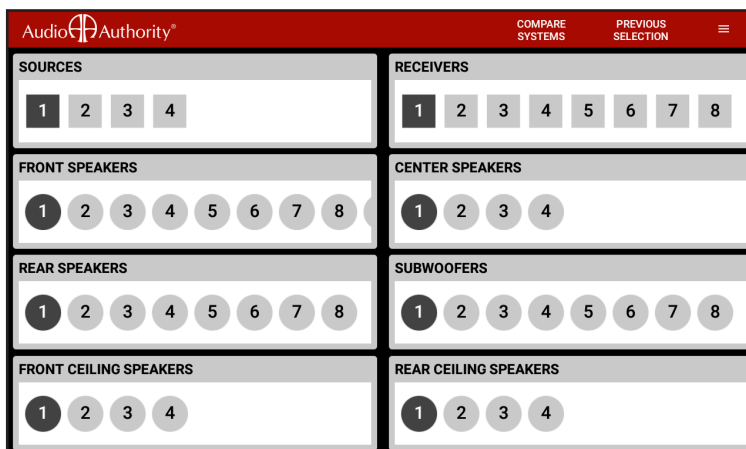

Figure 9. 903i main menu.



Figure 8. Stainless steel product select button with blue LED.

## System Module

### 980B System Control Module

System Module performs vital tasks within the Access™ System such as SilenTouch™, speaker limit, and provides an interface for a legacy 903 Control Panel. One per system.

## Special Modules and Devices

These modules provide extra capabilities, and are not required for many systems.

### 974 RS-232 to USB Interface

The 974 connects the Access System Bus to the 903i Comparator.

### HDMI Switching Control Module

The 970A-1 can be programmed to interface with an HDMI switcher, so that HDMI sources can be controlled via product select button or control panel in harmony with the Access demonstration network. Ask your Account Manager about custom programming for HDMI.

### 977 Digital Audio Adapters

977R converts optical (Toslink) digital audio signals to coax, and 977T converts coax digital audio signals to optical.

### 979 Audio Converters

979R converts 2-channel digital audio signals to analog, and 979T converts analog audio to digital PCM.

### 1322D EDID Control Module

1322D EDID Controller edits the EDID table to present the preferred settings to a source device.

## Signal Expander Modules

Expander modules add channels to main switch modules.

### 920X Low-Level Expander

2-channel low-level expander used to add more channels to a main switch module.

### 932X Speaker-Level Expander

Eight speaker expander used to add extra speaker (*E.G. Rear*) channels to Model 932.

### 940X High-Level Expander

2-channel high-level expander used to add channels to a main switch module.

### 949X High Current Speaker-Level Output Expander

2-channel expander used to add a high current subwoofer amplifier channel to Model 922 or 942.

## Switching Modules

The following modules are the main backbone of an Access switching system. They are connected together via a System Bus over which they communicate with each other and the control panel (if used).

## Source Switching Modules

### 922 (Low-Level) Selector Module

Model 922 controls four 2-channel audio sources. May also be used for switching powered subwoofers.

### 955 Source Selector Module

Model 955 controls four audio/video sources, including digital audio (coax) as well as composite video. Bus connections are directional (IN from previous source module/OUT to next source module or to next product group.)

## Receiver, Amplifier and Soundbar Modules

### 942 Amplifier Selector Module

Model 942 controls four two-channel amplifiers or receivers. One module accommodates both low-level inputs and high-level outputs. For high current amplifier applications, use 922 for input, but dock a heavy duty 949X module to it to switch the high current speaker output signals (See also 939 below.)

### 945 Receiver Selector Module

Model 945 controls four Surround Sound or Digital Audio receivers. One module accommodates low-level and Digital Audio inputs and front/center/surround high-level outputs, as well as low-level Subwoofer output. Bus connections are directional (IN from previous receiver module or previous product group/OUT to next receiver module).

### 956 Soundbar Selector Module

Model 956 controls four soundbars, digital-to-analog converters, or receivers (with dedicated speakers). One module accommodates digital (Toslink®) and stereo analog inputs allowing PCM, Bitstream, Dolby TrueHD and DTS TruSurround.

## Speaker Modules

### 932 Speaker Selector Module

Model 932 controls one channel (e.g. left or right) of eight speakers. Two 932 modules are required for eight stereo pairs. Use one 932 for center speakers or speaker level subwoofers.

### 939 High Current Speaker Selector Module

For high current applications, use 939 in place of 932 switch modules (See also 949X on page 7).

### 940 High-Level Selector Module

Model 940 controls four speaker pairs, but does not offer SilenTouch™ or AutoDamping™. Use Model 932 for applications where SilenTouch™ and AutoDamping™ are desired.

## Single Product Group Switching Systems

### Individual Access Modules

Most products can be switched with a single Access™ module, and generally, a 980 System Module. Product Select Buttons (PSBs) may be installed next to each product or a 906 Single Product Group Control Panel can be used. If the system is expanded to switch multiple sources, receivers and speakers, the Access™ system can be modified by adding the necessary switching modules. This section provides a general overview of system layouts; for detailed hookup instructions, see Appendix A.

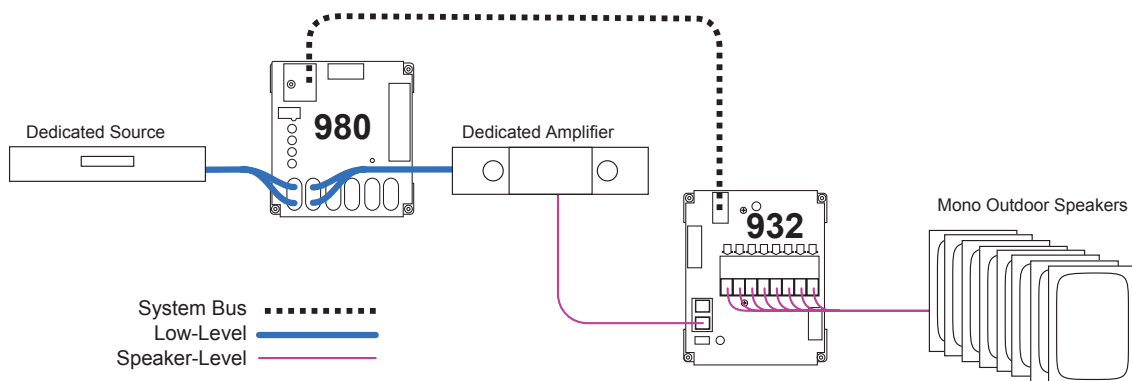

Figure 10. Mono outdoor speaker display.



## Audio Sources

Use a 922 Low-Level module for every four CD players, music servers, or satellite radio receivers you plan to include in your switching system (Figure 10). Connect each source to a 922, and connect the system bus and low-level bus from the 922 module to the “Bus In” jacks on the 980 System module. Connect an RCA patch cord from the low-level “Bus Out” jacks on the 980 to the CD input of a dedicated receiver and add a pair of speakers to complete the display. To add more sources, add 922 modules. For example, to add sixteen sources, connect system bus and low-level bus from the first 922 to four more 922 modules.

## TV Soundbars

Use a 956B module (Figure 11) for every four soundbars to be demonstrated. The HDMI video from the source connects to the TV. The 956B switches any digital audio format including Dolby®. To add soundbars to your display, add 956B modules. For example, to add eight soundbars, add two 956B modules. Connect all modules with system bus, and all 956B modules with audio/video bus. Be sure to follow signal flow when connecting bus jacks labeled IN/OUT.

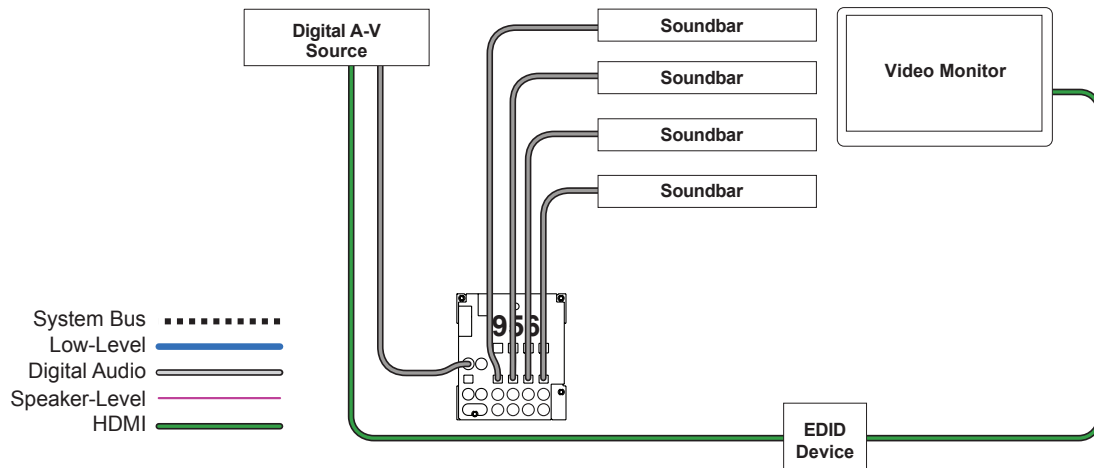

**Figure 11.** Four Soundbars with dedicated TV. Insert an EDID control device in the HDMI pathway to choose an audio soundstage; otherwise the TV may cause the source to output 2-channel PCM. Note the 956 accepts coax or optical signals from the source.

## Surround Receivers

Use one 945 module for the input/output for every four receivers (Figure 12). The analog audio bus connects the dedicated source to the 980 module, and from there it links all the 945 modules in the receiver group. Be sure you properly connect the bus according to signal flow. The digital audio bus comes directly from the dedicated source to the 945 module’s IN jacks. Connect all main modules with system bus and speaker bus (for more detail, find “bus cable installation” in the index.) To add receivers, just add switching modules. For example, to add 12 receivers to a surround switching system, add three 945 modules.

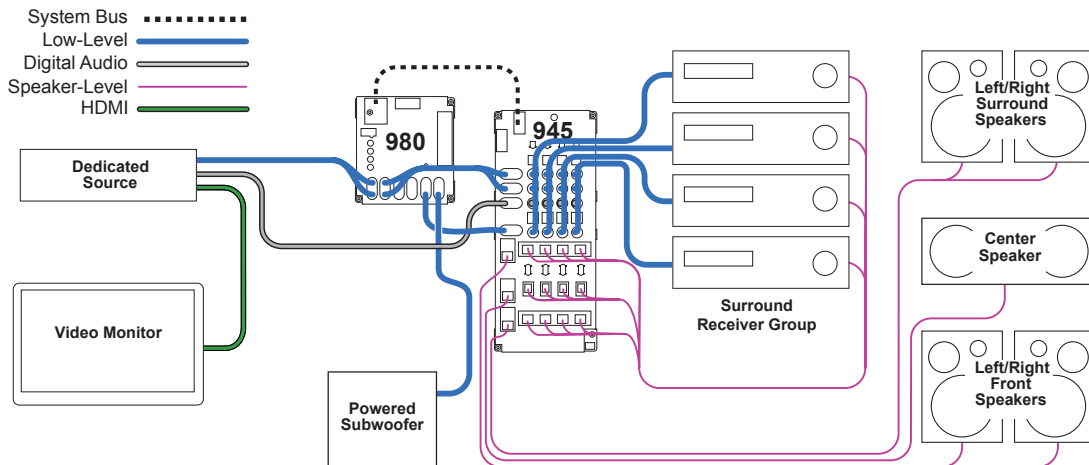

**Figure 12.** Four surround sound receivers with dedicated source, TV, and speakers. Note the subwoofer signal path is routed through the 980 for SilenTouch.

## Stereo Receivers

Use one 942 module for the input/output for every four stereo receivers (*not shown*). The low-level bus connects the dedicated source to the 980 module, and from there it links all the 942 modules in the receiver group. Connect all main modules with system bus and speaker bus (for more detail, find “bus cable installation” in the index.) To add receivers, just add switching modules. For example, to add sixteen receivers to a 2-channel switching system, add four 942 modules.

## Stereo Speakers

The 932 Speaker Module lets you place switching modules close to the merchandise, dramatically reducing wiring runs. Each 932 handles up to eight speakers in one channel (*Figure 13*). For every eight speaker pairs, use two 932 modules, one for the left speakers and one for the right. Install the 980 module between the source and the receiver in the low-level bus as shown. Connect the 980 and all 932 modules with system bus. To add speakers, add 932 modules. For example, to add sixteen speaker pairs, add two left 932s and two right 932s. To demonstrate four speaker pairs (or fewer), use a 940 module (*not shown*) and a 980 module.

**Figure 13.** All modules are connected by System Bus.

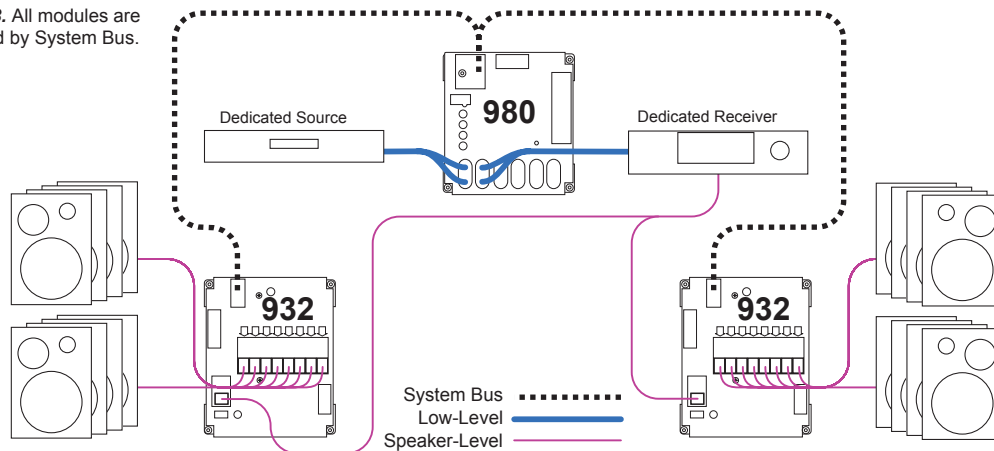

## Multi-Component 2-Channel Switching System

### Designing Your Own Application

Home audio demonstration systems can be designed in different ways. This section explains the *basic* switching configurations for a 2-channel display including several sources, receivers, and stereo speakers. The architecture of Access™ makes it possible to design a system that fits your needs exactly. Your Account Manager can help you choose the modules and user interfaces that will best suit your needs and product mix. If you wish to change your merchandising approach in the future, Access™ can be rewired and additional modules can be installed to accommodate a different configuration.

### Organize Products into Groups

When planning the installation, think of each component type you wish to display as belonging to a particular family or *group*, and where each component might reside in the signal path for a typical audio system. Generally the Product Groups fall into these categories: Sources, Receivers, and Stereo Speakers. Only one product can be selected from each Source and Receiver Product Group at a time. The Access system can allow up to four pairs of speakers to play at once in parallel, but you can determine that number by setting the Speaker Limit Switch on the 980 System Module.

**Note:** Some receivers are not recommended to play more than one speaker pair.

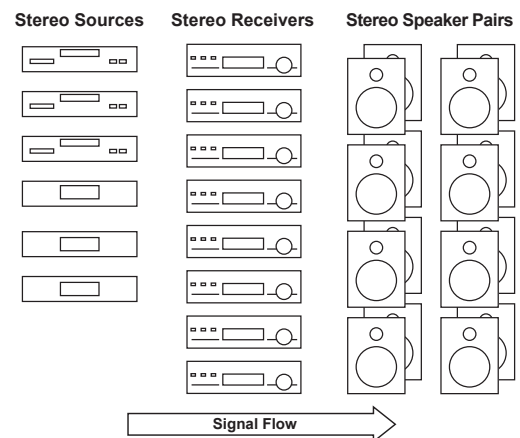

**Figure 14.** An example of basic Product Groups and their order in the signal path (left to right.)

## List the Switching Modules

Figure 15 shows the modules needed to switch each type of product in this example display. Each electronics module supports four products, and each speaker module supports eight speakers. To switch eight speaker pairs, use one 932 module for the right, and one for the left. The Access System's architecture was designed for up to sixteen unique speaker groups, with a capacity within each group for 99 pairs of speakers.

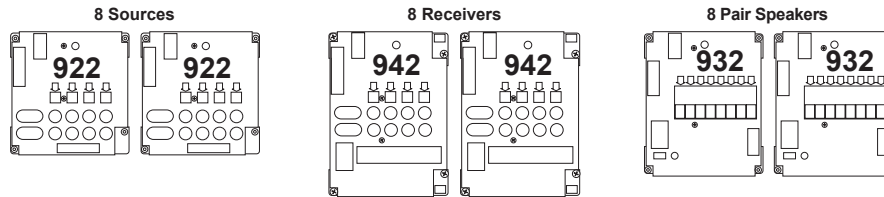

Figure 15. Switching modules needed for this example stereo switching system. For high power amplifiers, you may wish to substitute 949X and 939 modules for receiver group.

## Put the System Together

The only other essential module is the Model 980 "System Module" which controls certain functions of the Access System. A 980 System Module is shown installed in the signal path between the Source Group and the Receiver Group. By connecting the modules with bus cables (see page 18 for instructions) you now have a working switching system.

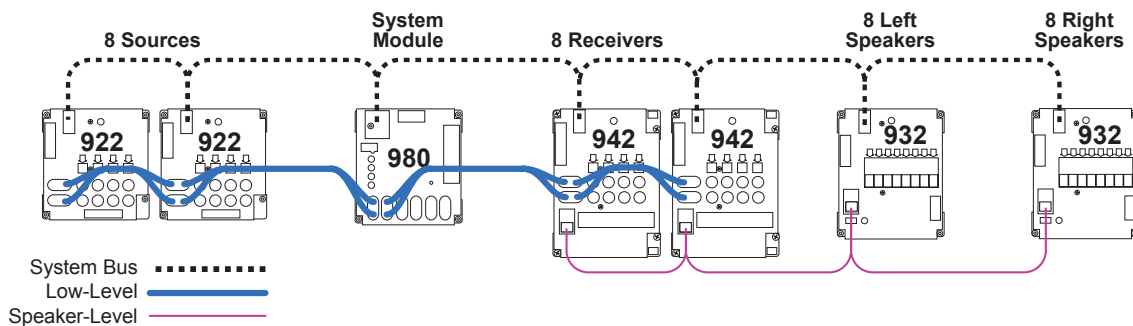

Figure 16. Typical small stereo switching system.

## How to Add Product Capacity

Simply add enough modules to accommodate the number of additional products you plan to demonstrate. Instead of eight sources and eight pairs of stereo speakers, the example in Figure 16 can switch twelve sources and sixteen pairs of speakers. If you plan to use a 903i Comparator, you can demonstrate up to 99 products in each of eight Product Groups

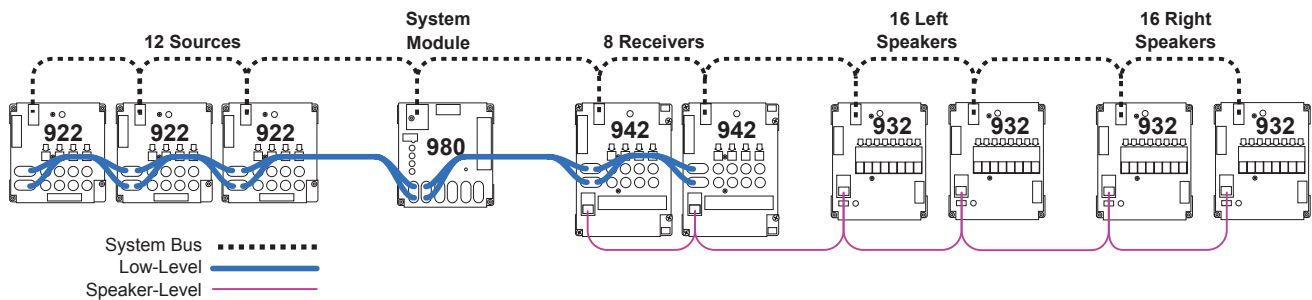

Figure 17. Expanded stereo switching system.

## Bass Modules with Satellite Speakers

Multi-speaker packages or "bass module" packages are referred to here as un-powered sets of speakers which are switched essentially the same as pairs of conventional speakers. They belong in the same Product Group as the other full range stereo speakers. A bass module with a pair of satellite speakers would be connected to the 932 switching modules on each side, and the satellite speakers would be connected to their bass module.

# Home Theater Switching System

## Designing Your Own Application

This section explains the *basic* switching configurations for a 5.1 channel display including several digital sources, Dolby Digital 5.1, 7.1 or Atmos receivers, surround speakers and subwoofers. Your Account Manager can help you choose the modules and user interfaces that will best suit your needs and product mix.

### Organize the Products

When planning the installation, think of each component type you wish to display as belonging to a particular family or “group,” and where those components might reside in the signal path, for a typical home theater system. Generally home theater Product Groups fall into these categories: A-V sources, digital receivers, center, front and surround speakers, and subwoofers. Only one product can be selected from each electronics Product Group at a time.

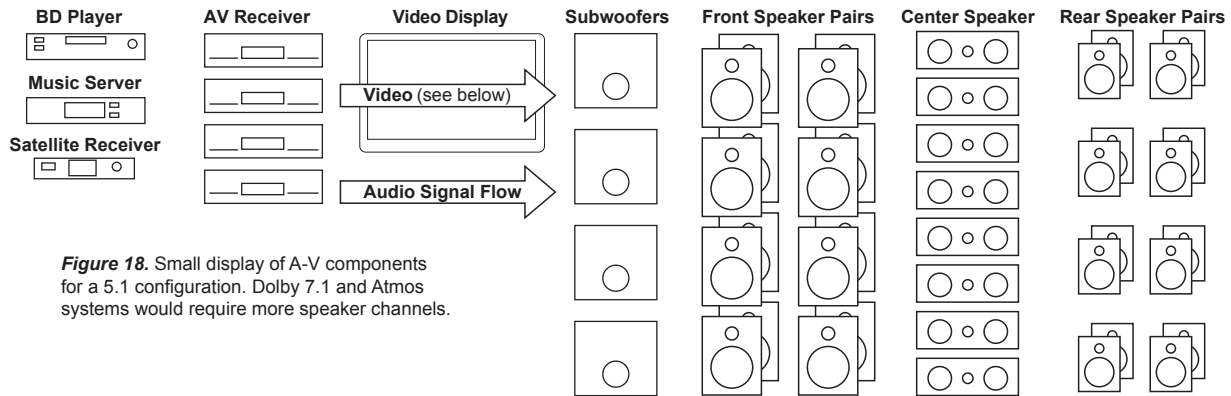

**Figure 18.** Small display of A-V components for a 5.1 configuration. Dolby 7.1 and Atmos systems would require more speaker channels.

### List the Switching Modules

Figure 18 shows an assortment of home theater products you may wish to demonstrate. Figure 19 shows the modules needed to switch each type of product in this example system. The Source Group may include DVDs, Blu-ray Players and streaming media devices. Each electronics module supports four products, and each speaker module supports eight individual speakers. To switch eight speaker *pairs*, you need two 932 modules: one for the right and one for the left. For small systems, you can use one 940 module to switch four stereo pairs. 932 modules are better for five or more speaker pairs because they will automatically prevent unselected pairs from vibrating sympathetically with the selected pair (AutoDamping™).

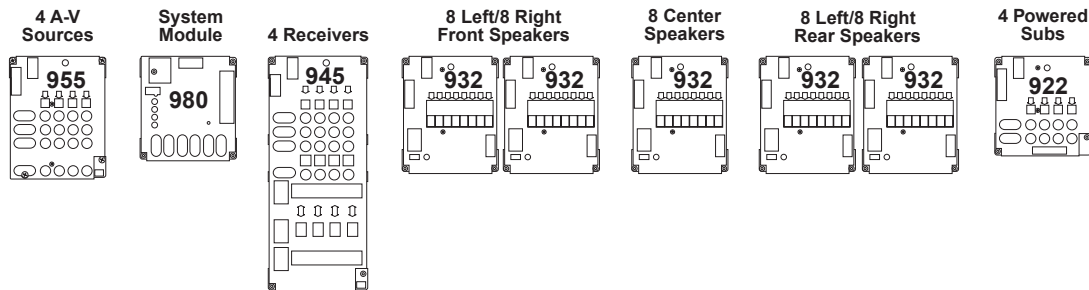

**Figure 19.** Switch modules required for this example system. Additional modules are required for 7.1 and Atmos configurations, see Appendix A.

### Video Signals

For demonstrating multiple video displays or projectors using HDMI, use our HDMI distribution amplifiers. If your merchandising plan requires HDMI video switching, Audio Authority can provide a customized 970A-1 to interface with an HDMI switch. See [audioauthority.com/hdmi-demo](http://audioauthority.com/hdmi-demo) for details.

## Put the System Together

The only other essential module is the “System Module.” It controls certain functions of the Access System, such as SilenTouch™ (a muting interval) and provides a place to connect a control panel and power supply. A 980 System Module is shown installed in the signal path between the Source Group and the Receiver Group. By connecting the modules with bus cables (explained in the definition of terms section) you now have a working switching system.

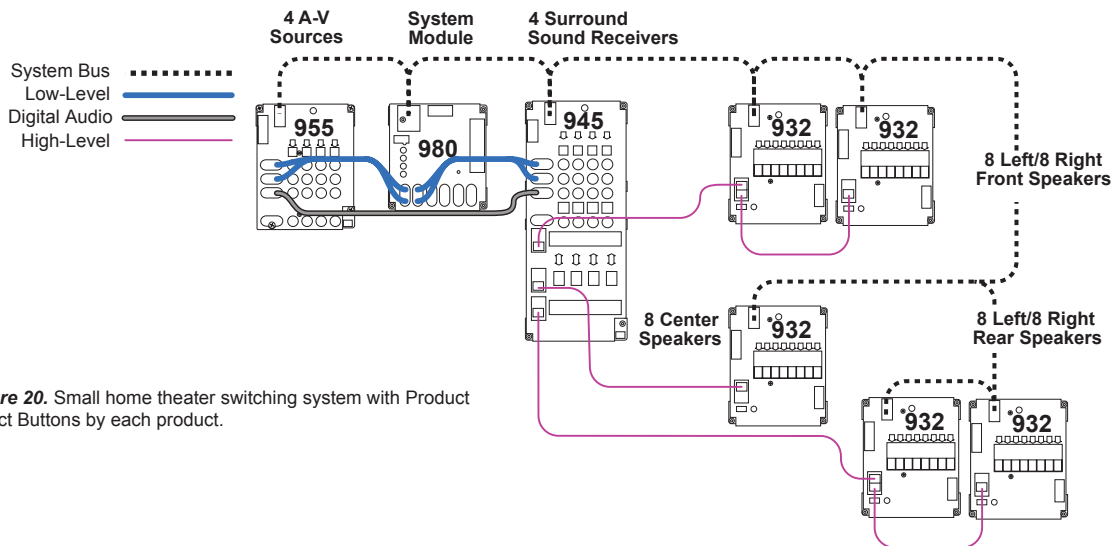

**Figure 20.** Small home theater switching system with Product Select Buttons by each product.

## Add More Products

Simply add enough modules to accommodate the number of additional products you plan to demonstrate. Instead of four A-V Sources, the example in *Figure 21* can demonstrate eight Sources. If you plan to use a 903i Comparator or PSBs, you can demonstrate up to 99 products in each of eight Product Groups.

## Subwoofer Switching Options

Powered subs can be wired low-level in systems where all receivers have a low-level “Sub Out” jack, or they can be wired high-level, tapping into the full range signal for the front speakers. Call Audio Authority® for more information on wiring high-level subwoofers. Low-level mono or stereo subwoofers can be switched using the 922 module. For mono subwoofers, use only one channel or use a Y-adapter cable (shown below) to provide signal to both channels, reducing hookup errors.

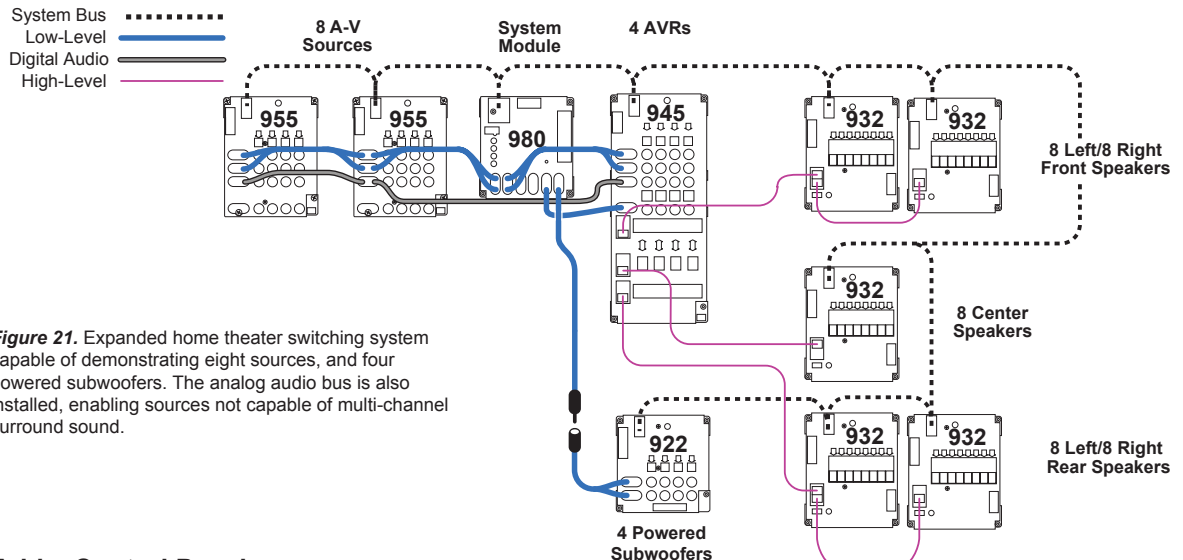

**Figure 21.** Expanded home theater switching system capable of demonstrating eight sources, and four powered subwoofers. The analog audio bus is also installed, enabling sources not capable of multi-channel surround sound.

## Add a Control Panel

This system would have Product Select Buttons by each product, but with the addition of a control panel, products could be selected on it directly. The control panel would be connected to the 980 System Control Module as shown in the section called “Adding Control Interfaces” on page 14.

# Video Distribution Systems

## Working with HDMI Signals

For a simple video demonstration where one source device feeds HD video to multiple displays, our HDMI distribution amplifiers are ideal. You can also use it as part of the solution when demonstrating HDMI via multiple AVRs. If the capability for video on-screen programming is desired, the video bus from the source group must be looped through the Receiver Group, and then connected to the video distribution system. That configuration requires an HDMI switcher as well. Choose a switcher with RS-232 so that it can be controlled using our Model 970A with custom programming. See an example system here: [www.audioauthority.com/page/hdmi\\_audio\\_demo](http://www.audioauthority.com/page/hdmi_audio_demo) or call for consultation about your specific needs.

## Adding Control Interfaces

### One Interface or a Combination of Interfaces

Your system may be operated by PSBs alone, or you can use a control panel, or both. Your Audio Authority® Account Manager can help you choose the user interface combination that best suits your needs. Call 800-322-8346.

### 903i Comparator

This full featured touch screen offers all the selling tools necessary for an effective presentation by qualified sales staff. The 903i uses the Model 974 to easily interface with the Access System Bus.

### 906 Control Panel

This single product group control panel plugs into the system bus port on any Access switch module. Set the address switches to match the address of the target product group's switch modules. Multiple 906 control panels may be used in one system, e.g. one 906 controlling sources, another 906 controlling receivers, and a third 906 controlling speaker pairs.



Figure 22. 903i Comparator



Figure 23. 906 Control Panel



Figure 24. 974 USB Interface for 903i Comparator.



[audioauthority.com/access\\_tips](http://audioauthority.com/access_tips)

# Installation

## 1. Preparation

Follow these steps carefully:

- Look at the supplied system wiring diagram, or choose one from this manual to serve as an example. Examples are in Appendix A: Sample Systems.
- Gather the owner’s manuals of other products that are part of your system for reference during the installation.
- Gather the tools and materials you will need. The list below will cover most installations.
  - #2 Phillips screwdriver bits
  - 1/8” straight (flat head) screwdriver
  - Power screwdriver (especially one with a torque clutch)
  - Wire cutter/stripper
  - Cable ties (4 inch are fine)
  - Drill bits for PSBs; 5/8 inch (999A), 1 1/8 inch (999), and 3/4 inch (999S)
  - Flashlight
  - 14-18 gauge speaker wire
  - High quality RCA patch cords. Any RCA patch cords are suitable for the low-level bus or component connections; however, we highly recommend that you use low-capacitance RCA patch cables for optimum system performance and reliability, especially when demonstrating turntables, or when longer cable runs are necessary.



999A



999



999S

- Check the contents of the shipping cartons. If your system is not pre-installed in a fixture or on workboards, use the packing list and your wiring diagram to determine how each component fits into your wiring plan. Refer to the “Access System Components” section of this manual to help identify the various items.

## 2. Addressing

### A. Number the Product Groups.

Each main switching module has a set of switches for assigning the unique ID or address of that module. First, determine the portion of the address called the Product Group number. Refer to your system plan to make a chart like the one below. Start with a Source Group if there is one; otherwise, start with the first Product Group in the audio signal path to be switched (TV monitors are not “switched” so they are not assigned a Product Group number.)



TECH TIPS

Electronics Product Group	Speaker Product Group	Product Group Number	Control Panel Display
Sources	-	0	1
Processors, Preamps	-	2	2
Receivers, Amplifiers	-	4	3
-	Front Speakers	4	4
-	Center Speakers	5	5
-	Surround Speakers	6	6
-	Subwoofers	7	7

Each group must have a higher number than the previous group in the signal path. Some numbers may be skipped if appropriate. Note that the receivers and *front* speakers always have matching group numbers.

Be sure to set the receivers to the same Product Group number as the front speakers.

## Speaker Groups

The Access™ System allows a maximum of 16 unique speaker groups, with a capacity within each group for 99 pairs of speakers. Some of the unique speaker group possibilities are:

- Front Speakers
- Center Speakers
- Rear Speakers
- Surround Speakers
- Side Speakers
- Center Rear Speakers
- Ceiling (Atmos) Speakers
- High-Level Subwoofers
- Low-Level Subwoofers

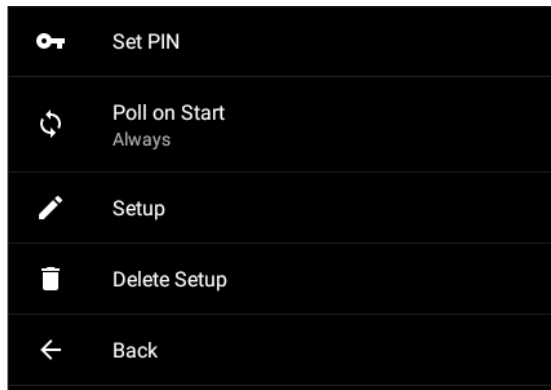

Figure 25. 903i Poll on Start (Always).

## B. Determine the Module ID settings

Number the modules in each group to put the products in the desired order in the group. Use the following table for the appropriate module ID setting for each module. The 903i Comparator Polls the Access modules that are connected to the system if Poll on Start is ON (Always) (shown in Figure 25). After the system is configured, touch Poll on Start and slide the button on the right to the OFF position.

See the chart below for the correct Module ID setting for each module.

### Source, EQ and Receiver Modules

Switching Module (922, 956, 955, 942 and 945)	Product Positions for Electronics Modules	Set the MODULE ID to:	
		Slide Switch	Rotary Switch
1st module	1 - 4	0 - 9	0
2nd module	5 - 8	0 - 9	1
etc...	9 - 12	0 - 9	2
	13 - 16	0 - 9	3
	17 - 20	0 - 9	4
	21 - 24	0 - 9	5
	25 - 28	0 - 9	6
	29 - 32	0 - 9	7
	33 - 36	0 - 9	8
	37 - 40	0 - 9	9
	41 - 44	10 - 19	0
	45 - 48	10 - 19	1
	49 - 52	10 - 19	2
	53 - 56	10 - 19	3
	57 - 60	10 - 19	4
	61 - 64	10 - 19	5
	65 - 68	10 - 19	6
	69 - 72	10 - 19	7
	73 - 76	10 - 19	8
	77 - 80	10 - 19	9
	81 - 84	20 - 29*	0
	85 - 88	20 - 29*	1
	89 - 92	20 - 29*	2
	93 - 96	20 - 29*	3
	97 - 99	20 - 29*	4

### Speaker Modules (8-Position)

Speaker Positions for 932, 939 Speaker Modules	Set the MODULE ID to:	
	Slide Switch	Rotary Switch
1 - 8	0 - 9	0
9 - 16	0 - 9	1
17 - 24	0 - 9	2
25 - 32	0 - 9	3
33 - 40	0 - 9	4
41 - 48	0 - 9	5
49 - 56	0 - 9	6
57 - 64	0 - 9	7
65 - 72	0 - 9	8
73 - 80	0 - 9	9
81 - 88	10 - 19	0
89 - 96	10 - 19	1
97 - 99	10 - 19	2

### How to Use These Tables

Read across from left to right. For the 1st module's addressing sequence (products one through four) set the MODULE ID to "0 - 9" on the slide switch, and "0" on the rotary switch.



### C. Set the Address Switches

Remember, begin with Group 0/ 00 for the first module in the Source Group, and the next module is 0/01. If the Receiver Product Group is next, the first 945 module will have an address setting of 4/00 (Figure 26), so the first module in the Front Speaker Product Group would be 4/00 as well (Figure 27). For an example system showing addressing, see Appendix A.

### D. Set the Programming Switches

Determine the settings for any remaining switches on each module.

#### S M B T D (Single Ch., Multi Ch., Bypass, Time, Delay)

The 942 Amplifier Module has an array of five switches used mostly for Car Audio Demonstration. All of these switches should be OFF in a home audio demonstration system unless Bypass is required.

#### Bypass

The Bypass switch should be set to OFF unless you wish to bypass the Source Group. A recordable DVD player is an example of a Source Group that might be bypassed. The Product Group will be bypassed when all the products in that group are unselected. **The “bypass module” is always the last module in the Product Group** (only the bypass module should have the Bypass switch ON). For more on bypass, see the index.

#### Left – Right

The 932 Speaker Module (shown right) has a Left – Right switch in the lower left-hand corner. For Left speakers, switch it to the “left,” for Right, to the “right.” For speakers such as mono centers or mono subwoofers, the switch should be set to the “right” position.

### E. Fill Out the Labels

Check all switch settings against your addressing plan or system drawing. Each module has blank boxes printed on the metal case. After you have established your switch settings, use this space to record the correct settings. Fill in the outlined arrows with the actual product numbers to be switched by this module as shown in Figure 27. This process will help with maintenance and troubleshooting later.

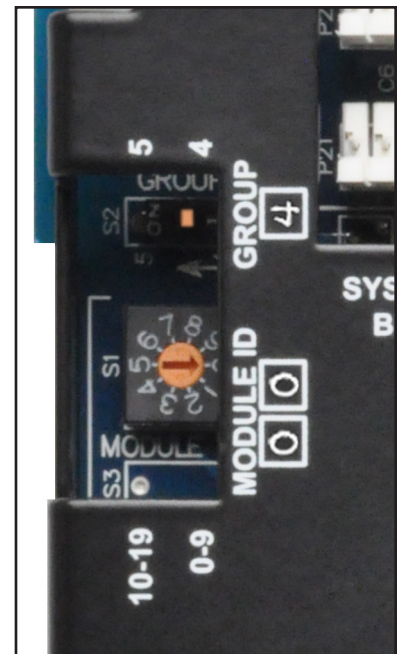

Figure 26. Model 945 Receiver

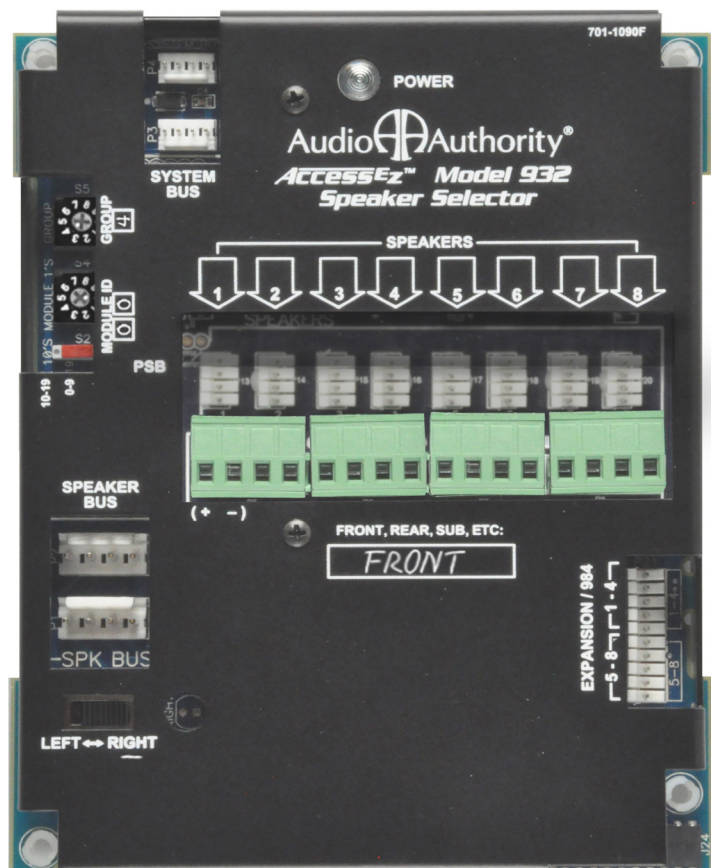

Figure 27. The 932 module serving the right channel of speakers 1-8 (note the filled-in identification boxes.)

### 3. Install the System Hardware



#### A. Designate the Switching Module Locations

Determine the location for each switching module. Each module controls either four or eight products.

- Follow your system plan design to determine the location of the switching modules in the display fixture. If you are using bus cables provided by Audio Authority®, you may wish to connect all the modules that share the system bus with system bus cable, power up the system on a bench or table, and check the switching modules and control panel logic before actually installing the modules in your fixture.
- Mark the location of the switch modules near the center of the products they will serve. Modules will serve four electronic components, or eight speakers.
- Be sure to consider the two foot plug spacing if you are using pre-made factory bus cables.

#### B. Determine Other Module Locations

In the following installation steps, ignore any references to modules that are not part of your system.

- Position the 980 System Module in the signal path immediately prior to the first module(s) in your Receiver Product Group. This position will allow you to feed analog audio signals from the output of your Source Product Group to the System Module which will then feed the low-level input signal to your Receiver Product Group. Do not route video or digital audio signals through the 980 module.

#### C. Mount the Modules

- Use the screws provided with each module.
- Connect any audio signal expander (“X” module) to its respective main switching module by plugging it directly into the bottom of the main module as shown. If you encounter difficulty with this procedure, call the factory. It is critical that any signal expander modules be connected to a header port on the main module labeled “Expand” or “Expansion.”

Do not plug an audio signal expander module to the header port labeled “DC Expansion” on the top of 922, 940 or 942 modules (See Figure 28).

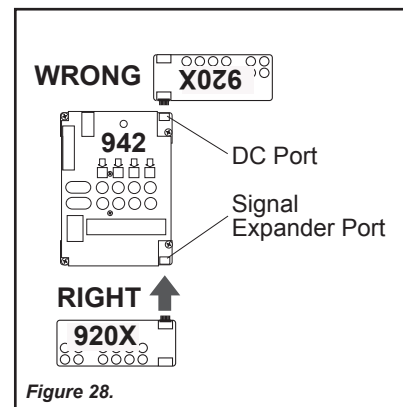

### 4. Install the Bus Cables

Pre-assembled bus cables or the raw materials to make the necessary bus cables on the job site were included with your system purchase. Pre-assembled bus cables have connectors every two feet (RCA patch cords are available in lengths from three to twenty feet.) If you plan to make your bus cables on the job site, you’ll need connectors and the special bus assembly tool.

If you are making your own bus cables, be very careful to follow the assembly instructions, especially concerning wire to connector polarity. Incorrect bus fabrication can cause system failure and damage! Several types of bus cables are available for specific purposes:

Cable Type	Color Code	Pre-assembled Part Number	Cable for Site Assembly	Plug for Site Assembly	Assembly Tool
System Bus	yellow/red/blue/black	802-307	871-055	916-0470	762-011
Speaker Bus	green/white/brown/gray	802-186	871-045	904-172	762-009
Low-level Bus	RCA patch cords	801-018 to 801-023	NA	NA	NA
System extension*	yellow/red/blue/black	802-323	871-055	916-0470	762-011
Speaker extension*	green/white/brown/gray	802-309	871-045	904-172	762-009
Module expander	red/grey/purple/blue/green	802-177			

\* The System and Speaker Bus extension cables allow you to join remote sections of the Access™ System with the main electronic component section of your display, as in the case of surround speaker modules in a home theater display fixture.

## A. Install the System Bus

The System Bus allows all of the Access™ components to communicate among themselves, and with the control panel. You may use either header in the location labeled System Bus. Do not connect System Bus to any expander modules such as the 920X, or 940X. Be careful to observe the correct polarity as shown in *Figure 29* (header connectors are keyed for polarity).

1. Either use pre-assembled bus cables, or assemble bus with cable and 4-pin plugs (part number 916-0470) using the special assembly tool. If you are making your own system bus, be sure to leave a small amount of slack in the wire between the modules and be very careful to assemble the connectors with the wires in the correct order.

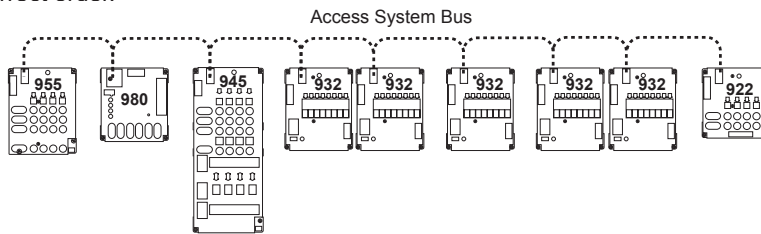

2. Starting at one end of your system, mate one plug of the system bus cable with either of the 4-pin headers in the location marked System Bus on each module as shown in *Figure 30*. If one cable is not long enough, or if you want to make a branch from your cable run, you may begin another run by plugging it into the vacant System Bus header. Otherwise, that header may be left vacant.
3. If you are using pre-assembled buses, you may use a system bus extension cable for long distances between modules. (Or carefully splice 22 gauge cable where needed, call Tech Services for assistance)

## B. Install the Speaker Bus

The Speaker Bus will be used to send high-level signals from receiver outputs to other high-level modules in the system. It is a green/white/brown/gray cable.

- Be careful to maintain correct polarity as shown in *Figure 31*.
- Install the Speaker Bus in the same way you installed the System Bus. For stereo switching systems, plug a 4-pin Speaker Bus connector into a header marked Speaker Bus on every 942 module.
- For surround sound switching systems, make three individual buses: Front, Center, and Rear Speaker Bus. Begin at one end of your Receiver Product Group, and plug the first Speaker Bus into a header marked Front Speaker Bus on each 945 module. Plug the next Speaker Bus into a Center Speaker Bus connector on each 945, and the last bus into the Surround Speaker Bus headers in the same way.
- Now connect the Speaker Bus (or Buses) from the Receiver Product Group to the Speaker Product Group (or Groups for surround sound systems). Plug one end of the Front Speaker Bus into a 942 or 945 module, then plug a Speaker Bus connector into a header marked Speaker Bus on every 932 module in the Front Speaker Product Group. If it is more convenient, connect one channel (e.g. Left) with one run of bus cable, and the other side with a separate run of cable. Continue in the same way with the Center and the Surround Speaker Product Groups.

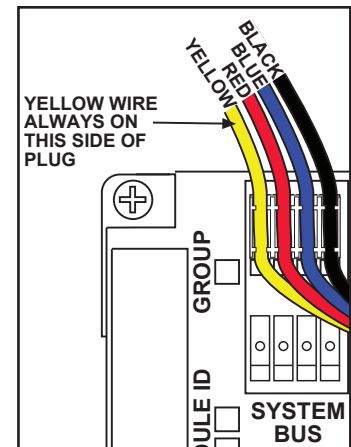

*Figure 29.* Observe correct System Bus polarity. It is fine to leave one header unused.

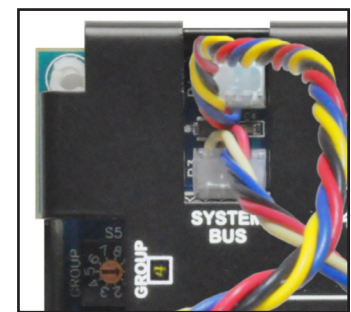

*Figure 30.* System Bus cable branching off.

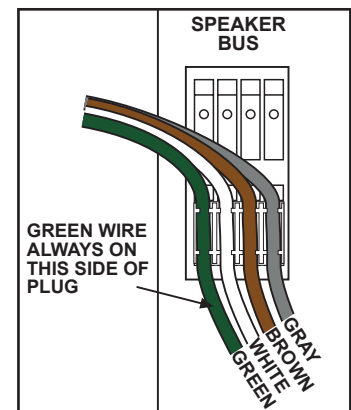

*Figure 31.* Keyed Speaker Bus port.

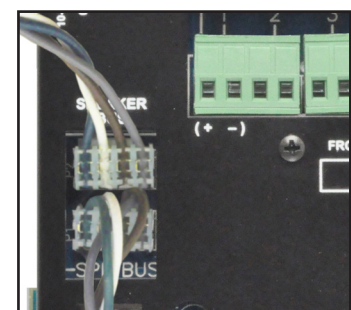

*Figure 32.* Speaker Bus cables branching off.

### C. Install the Low-Level Buses

- The Low-Level buses carry signals from the Source Product Group to the Receiver Product Group via RCA patch cables. Be sure to observe IN/OUT bus wiring on 955 and 945 modules.
- The Left and Right Audio Bus begins in the Source Product Group, and continues through the Bus In and Bus Out jacks of the 980 and then on through the Receiver Product Group.
- The Digital Audio Buses follow the same route, but DO NOT loop through the 980 module. Connect them directly from the Digital Audio Bus Out jacks on the 955 modules to Digital Audio Bus In jacks on the 945 modules.
- The Subwoofer Output Bus is connected from one 945 to the next, and finally ends up at the Subwoofer Product Group.

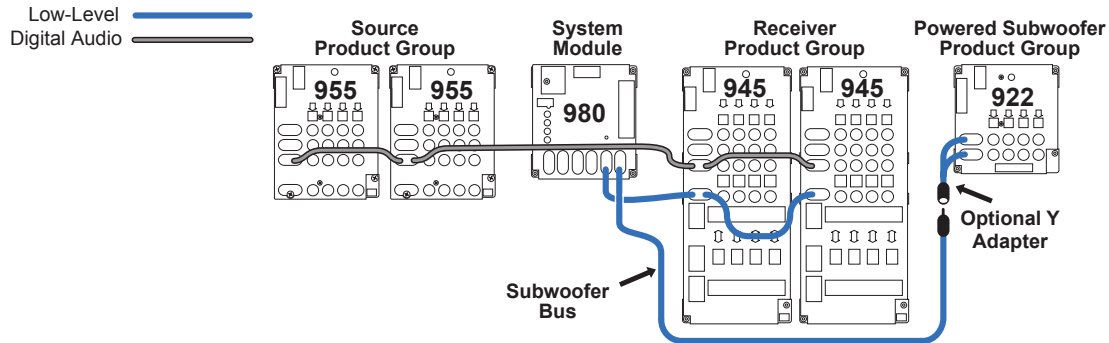

**Figure 33.** Subwoofer Bus shown with Y adapter at switch module. Subwoofers can also be wired mono, and Y adapters applied only to the inputs of each stereo subwoofer.

### D. HDMI Switching and Video Distribution

The Audio Authority Distribution Amplifiers are easy to install. Some other rules are as follows:

- Each distribution amp should be permanently mounted as close as possible to the products it feeds, and within reach of an AC power outlet.
- For HDMI switching, see [audioauthority.com/hdmi-demo](http://audioauthority.com/hdmi-demo) for details.

## 5. Check Your Work to This Point

Before continuing any further, double check the following:

- Check the Group and Module ID settings on all modules. Your Group numbers should follow a similar pattern to the example in *Figure 34*. Make sure the Module ID settings are in consecutive order in each Product Group, beginning with zero, not skipping any numbers.
- Check any Expander Modules in the system to insure that audio signal expanders are connected to the Expansion header on their main modules, and *not* a DC Expansion header. When docking 920X Expansion modules to speaker modules, ensure the 4-pin connector matches the correct positions (1-4 or 5-8).
- Check programming switches, especially the Left-Right switch. 932 modules on the left side of your display should be switched to Left, and on the right side, Right. For mono center channel speakers or mono high-level subwoofers, set the switch to Right.
- Check signal bus routing. Follow the physical path of signal buses from source group products, through intermediate product groups, and out to the speakers. **Check Bus In/Out wiring on 955 and 945 modules.**
- Check the System Bus and Speaker Buses for correct polarity, and make sure the keyed plug is engaged with all four pins on each header and in the correct direction as shown in *Figure 36*.



TECH TIPS

Product Group	Group #
Sources	0
Processor	2
Receivers	4
Front Speakers	4
Center Speakers	5
Rear Speakers	6
Subwoofers	7

*Figure 34.*

### Speaker Bus Polarity

Green = Left +  
White = Left -

Brown = Right +  
Gray = Right -

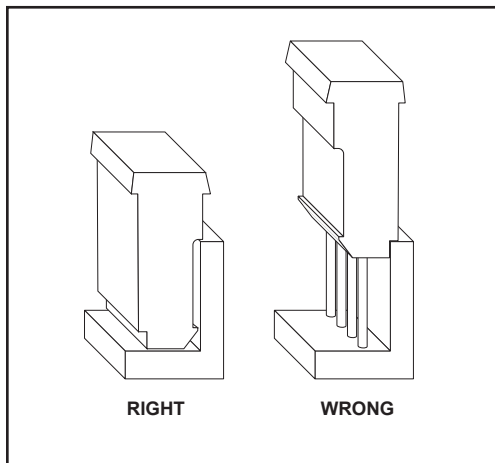

*Figure 35.* Keyed header plug orientation.

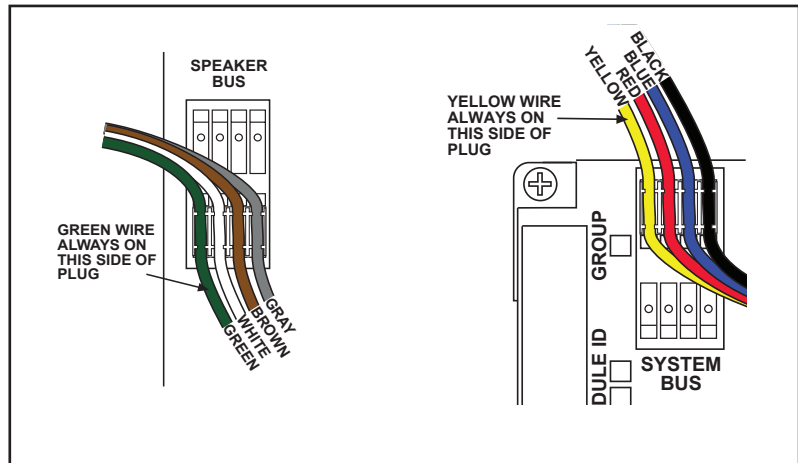

*Figure 36.* Observe correct polarity for all bus connections.



*Model 903i Comparator*



*Model 906 Control Panel*

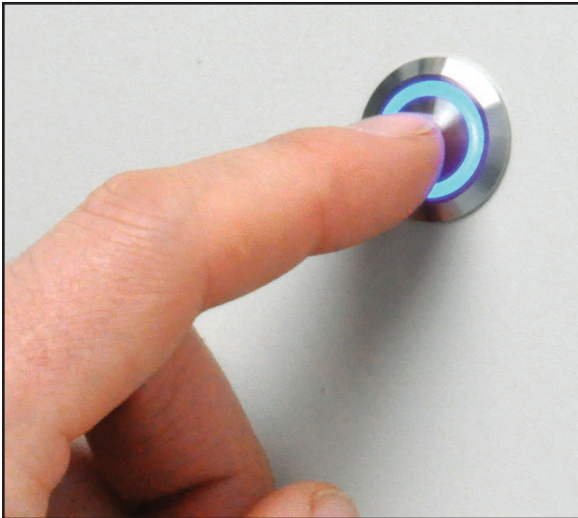

*Product Select Buttons*

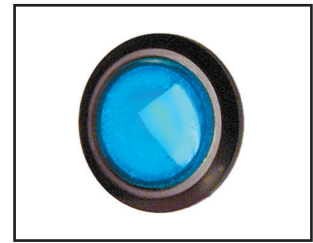
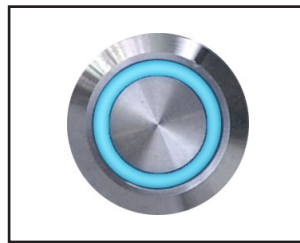

# Installing a Control Method

## 1. Installing a Control Panel

Skip this step if you do not have a 903i Comparator. If you have a 903i, it is accompanied by a separate User's Guide which you should locate for future reference.

- A. For a 903i Touchscreen, cut an opening 11.3/8" (289 mm) wide by 7.5/8" (194 mm) high. If the surface is wood, you may need to make a notch for the USB plug. Use the bezel to mark screw hole locations and drill holes for the screws.
- B. Connect the Model 974 USB to Serial Adapter system bus port to any vacant Access System Bus header. Connect the USB mini from the 974 to the 903i USB port (see Figure 37). Securely mount the Model 974. Connect Power and bottom cover.

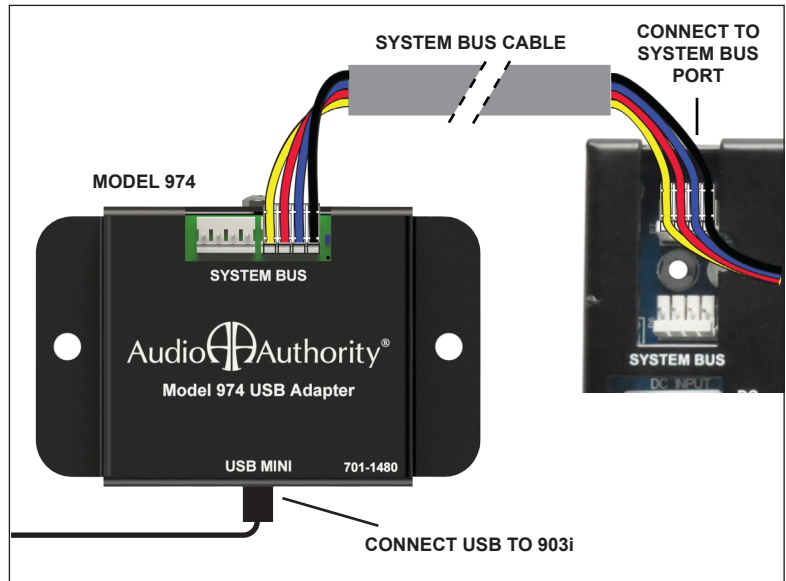

Figure 37. 903i connection diagram.

Skip this step if you do not have a 906 Control Panel. If you have a 906, it is accompanied by a separate User's Guide which you should locate for future reference.

- A. For a 906 Control Panel, cut an opening 4 -1/16" (105 mm) wide by 5 -1/8" (130 mm) high. Use the panel to mark screw hole locations and drill 7/64" (2.5 mm) holes for the screws.
- B. Set the Configuration Switches on the 906 control panel (See 906 Switch Settings on page 24.)
- C. Mount the 906 control panel using the four screws provided. **Do not overtighten the screws.**

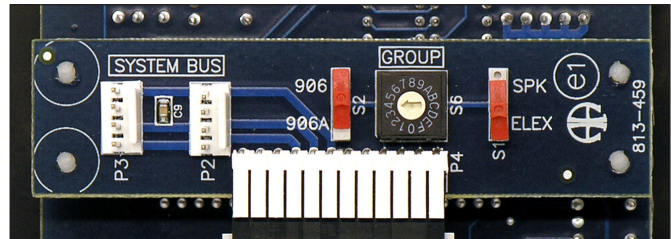

Figure 38. 906 Control Panel connections and settings.

## 906 Switch Settings

Switch	Function	Comments
906 / 906A	Primary/Secondary	This switch should only be in 906A mode when two 906 Control Panels are controlling the same product group.
Group	Address	Set this switch to the number of the Product Group it will control.
Spk / Elex	Speakers or Electronics	Set to Spk for controlling speaker groups, and Elex for controlling head units, eqs, and amplifiers.
Spk / Elex	Speakers or Electronics	Set to Spk for controlling speaker groups, and Elex for controlling soundbars, AVRs, or source devices.

### 2. Installing Product Select Buttons

You may use product select buttons (PSBs) alone, or in conjunction with a control panel.

A. Determine where each PSB will be located, usually close to the product the PSB will select, and often near product information tags.

- For plastic PSBs: drill a 1 $\frac{1}{8}$ " hole in the panel or surface. Remove the nut and feed the switch through the hole. Tighten the nut and install the white switch mechanism.
- For stainless steel PSBs: Drill a  $\frac{3}{4}$ " (19 mm) hole. Maximum panel thickness is  $\frac{1}{2}$ " (12.5 mm). Required depth is 2" behind front panel surface. Tighten the nut.

B. You may wish to leave the PSB mounted in the shelf or product panel, or install them later, after your components have been mounted.

**Note:** When using 2-wire buttons on 4-pin headers, use the left pair of header pins (shown below).



**Figure 39.** Top: Plastic BRB Button. Bottom: Stainless Steel Button

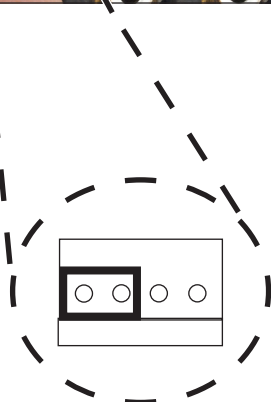
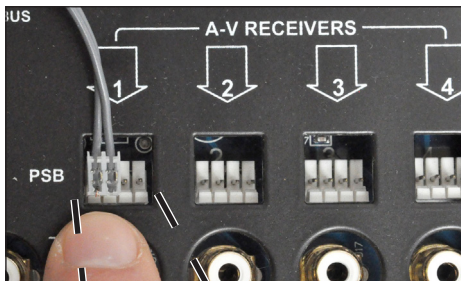

**Figure 40.** Use left pair header pins for 2-wire buttons.

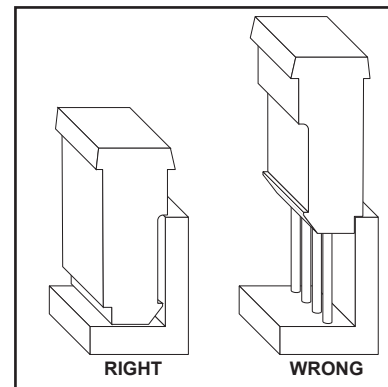

**Figure 41.** Be careful to maintain PSB cable polarity with keyed plugs.



### 3. Installing Remote Switches (980 System Module)

It is often desirable to add “outboard” switches for remote operation of certain system management tools.

#### A. Remote Power Switch.

- If your system does not include a Control Panel, you may want to turn the system on and off using a remote key switch or toggle switch.
- Use any SPST (single-pole, single-throw) switch you prefer. Low current switches will work perfectly well.
- Connect the switch between the “Power” and “Com” pins of the 980’s “Remotes” terminal block.

#### B. Remote System Reset.

- There is a “System Reset” button on the 980 that enables the user to reset the system in the unlikely event that the system “hangs up.” Pressing this button will re-boot the entire system. Having a Remote Reset switch is a good idea in any system since the 980 is usually buried inside the display and would not be readily accessible if the system ever needed to be reset. You may wish to “hide” this remote switch from customer view.
- Connect a SPST switch (*Figure 43*) between the “Reset” and “COM” pins on the “Remotes” terminal block located on the 980 (*See Figure 42*).
- Your system can now be “Reset” using this remote switch.

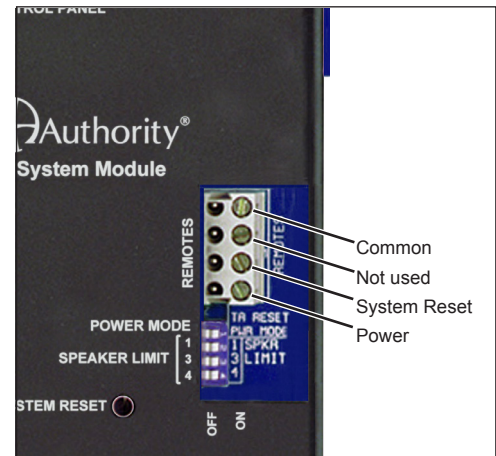

Figure 42. 980B Module

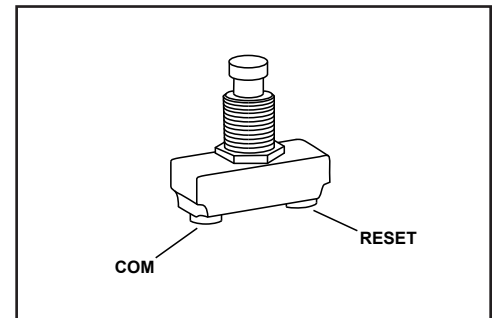

Figure 43. SPST Switch

# Testing System Function



## 1. Normal Operation

After installation is complete, all the system's components need to be tested. Apply power to the system and observe the following signs of normal operation:

- The green SilenTouch™ LED is lit on the 980.
- The green Power LEDs on the switching modules and the 980 are slowly blinking.
- The red 980 Low Voltage LED is not lit, or is very dim.

**Note: If the Low Voltage LED is brightly lit, your system will not function. Check the output voltage of your power supply and contact Audio Authority Technical Support.**

- For the moment, ignore the color of the clear LED "Bus Monitor" on the 980. Later, when product selections are made, you will notice that the Bus Monitor LED flickers orange. This orange flicker is normal. It merely indicates that "traffic" is present on the bus.

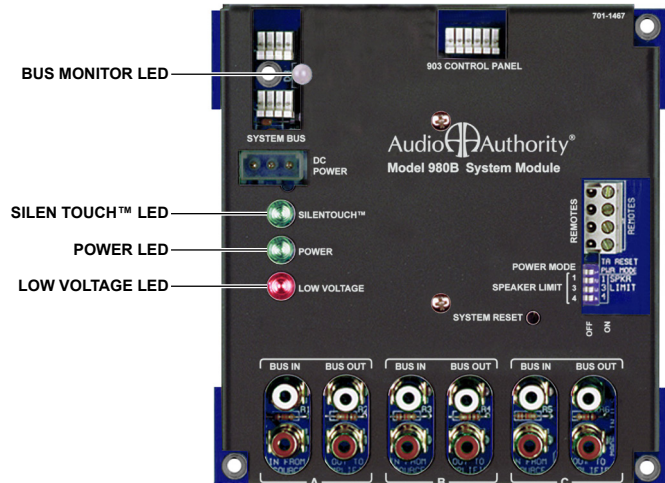

Figure 44. Model 980 System Module.

## 2. Testing the Product Positions

Use the PSBs (product select buttons) to select each position called for in the following procedures. If your system does not include PSBs, use a screwdriver to short one set of the two outside pins of the small 4-pin PSB port at each location as shown in Figure 46 and called for in the following steps.

1. Connect a PSB to one position on a switching module belonging to each Product Group and press the button. Watch for the following signs of normal operation:
  - The PSB lights.
  - The 980 SilenTouch™ LED blinks off momentarily.
  - The 980 Bus Monitor LED flickers orange.
  - Each product selected with the PSB is displayed in the correct Product Group card on the 903i.
2. Press a PSB (or short a PSB port) on a selected position in any group.
  - The LED goes out.
  - The 903i displays no positions selected in the respective product group window.

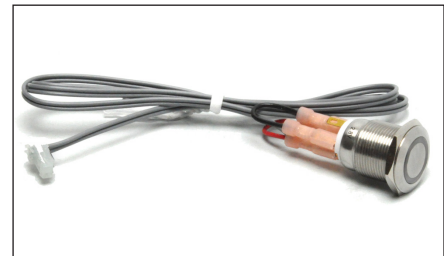

Figure 45. Stainless Steel PSB.

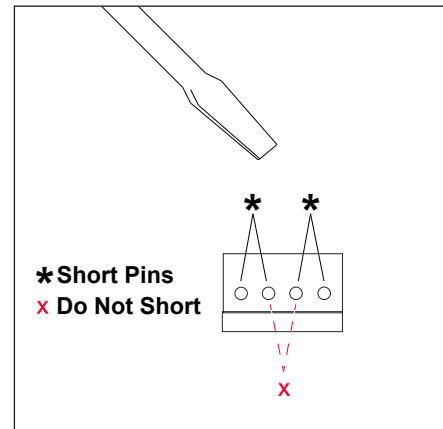

Figure 46. Test without a PSB by shorting pins.

3. Select a speaker position, then move the PSB to the same module location on the opposite side of the speaker section of the display.
  - The PSB lights up as soon as you plug it in, showing both left and right speaker positions are selected.
4. To select more than one speaker pair in a group, press the PSB and hold the button for at least one second (*Long Press*).
  - If the speaker limit setting on the 980 is set to 1, the PSB will not come on.
  - If the speaker limit is 2 or higher, the PSB will come on in both the first and second speaker position (factory default is 2, with 980 limit switches all in the OFF position). The 903i displays the two speaker positions selected in the speaker's Product Group window.

#### 4. Installing the Product Select Buttons

Connect the plug of the PSB's cable if PSBs are used, to the 4-pin headers on the circuit board at the corresponding product position. See *Figure 40* on page 24 if you are using 2-wire PSBs.

- A. Press the PSB into the hole (*Figure 48*) you drilled earlier in the mounting panel or display fixture and tighten the nut.
- B. Insert the switch into the PSB (*Figure 49*).

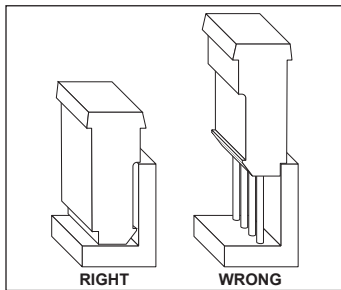

**Figure 47.** Correct PSB cable polarity.



**Figure 48.** Plastic PSB button assembly.

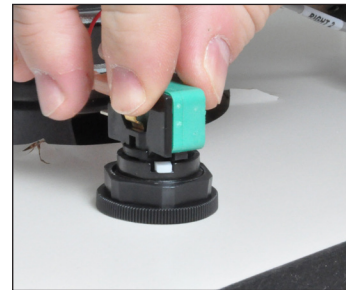

**Figure 49.** Inserting switch into PSB.

# Demo Product Installation

It is now time to begin installing the audio-video components. If you've followed the instructions so far, you will have a working system in short order. It may be a good idea to map out a wiring plan for the audio and video components before you begin connecting them to the switching system and to AC power. Make sure you will have access to the switching modules from either the front or rear of your fixture shelving.

Usually, it works out best to mount the components to be located at the bottom of your display first, and work towards the top of the display so you can avoid masses of hookup wire hanging down from above. Remember that the position of each component on the shelf should match the number you wish the control panel to display. For instance, in *Figure 50* the component in the display is on the bottom shelf, so it should be connected to the set of jacks on the switching module for component number 4. This unit will be number 4 on a 906 or 903i.

Be sure to save the boxes and accessories for the components so that you can offer your customer a new or almost new unit when you later take the component out of the display.

## 1. Install the First Products

Install one product in each group in order to get a simple system running. For example, install a source, a receiver, a pair of front speakers and a TV monitor. Leave your power source on but be careful using metal tools. If your system does not include PSBs, ignore any references to PSBs.

### A. Sources

Connect a source to an AC power outlet and its low-level audio or A-V outputs to a product position on the source module (*See Appendix B for hookup diagram.*)

- Connect the source unit to the product position on a 922 or a 955 Switch Module.
- Connect the low-level output to the source module's red (R) and white (L) female RCA jacks, and connect composite video output to the yellow RCA jacks if demonstrated.
- Connect Digital Audio outputs to a 955 module. If coaxial outputs are not available, use a converter such as a Model 977T.
- Connect the plug of the PSB's cable (if PSBs are used and are not already hooked up) to the PSB port next to the arrow with the number corresponding to the source you are connecting. *See Figure 40.*
- Install the device in your shelving or cabinet.

### B. Receivers

Connect a receiver to AC power. Then connect the receiver's audio inputs and speaker outputs to the 945 or 942 Receiver Selector (*See Appendix B for hookup diagram.*)

- Connect the receiver to the Audio jacks using high quality RCA and/or optical cables.
- Use 14 or 16 gauge speaker wire to connect the unit's speaker outputs to the corresponding terminal plug (front, center, surround). If you are switching subwoofers with low-level, use RCA patch cords to connect the Subwoofer output from the receiver to the 945.
- Install the unit in your shelving or cabinet.

### C. Speakers

Install a pair of speakers in the Front Speaker Group.

- Connect the left speaker to one of the two position terminal blocks on the Left 932 and the right speaker to the corresponding position on the Right 932. Wire the positive lead to (+) and the negative speaker lead to (-).
- Connect the plug of the PSB's cable, if PSBs are used, to the 4-pin headers on the 932 circuit board at the corresponding product position. Press the PSB into the hole you drilled earlier in the mounting panel or display fixture.

**Note: One PSB will activate both left and right speakers when selected. You may wish to install a PSB on both speaker locations for easy product selection.**

- Install the speakers in the shelving or cabinets.

## 2. Test Your Initial Product Installation

A. Select the test products using PSBs or the Control Panel. (See the 903i manual for detailed instructions.)

- On a 903i, select a product from one of the Product Group cards.
- Select the remaining test products in their respective Product Groups.

B. Adjust the product controls until you hear program material. If none is heard:

- Check for source material (Satellite receiver, DVD, Blu-ray, music server etc.).
- Check your product selection numbers on the control panel for accuracy.
- Check product connections to the switching modules.
- Make sure all products are receiving power.
- Check all Group, Module, and programming switch settings. Refer to the configuration on the information boxes and your system plan.

**Note: If you make any changes to any module's switch settings, press the System Reset button on the 980 System Module or cycle power. This enables the modules to recognize the new settings.**

- Make sure that PSBs, if present, are connected to the correct position.
- If PSBs are not installed, plug a test PSB into the respective ports or use the shorting method (see *Figure 45 on page 28*) on the switching modules to make sure that the products are currently selected to play.
- Follow the signal path visually through the product hookups and system buses to make sure there are no wiring errors or RCA cables that have been pulled loose. If you still have difficulty, call Audio Authority Technical Support at 800-322-8346.

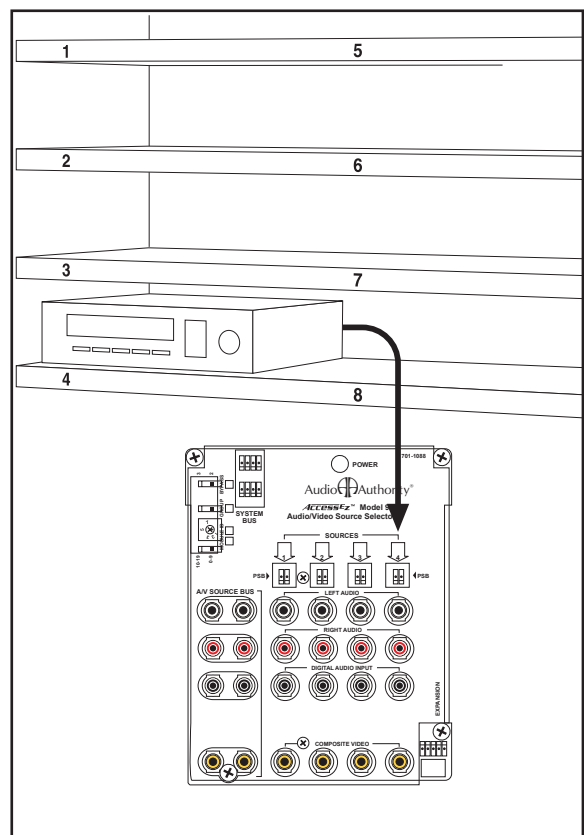

Figure 50.

## 3. Install the Remaining Products

- Install the rest of the sources, receivers and speakers by groups.
- Check all connections in each product group as it is completed.

## 4. Test All Products

This section covers operation of Access™ Systems using PSBs rather than a Control Panel. For operation of systems utilizing a control panel, please see the separate User's Guide included with the control panel.

1. Make sure the system is on (check power lights on switch modules).
2. Select products to play by pressing the PSBs next to one product in each product group. The PSB lights, confirming that the product is selected.
3. Adjust product controls to get the desired audio level.
4. Select a new product in any group by pressing its PSB. The previous selection is automatically canceled. Select every product in each group to be certain all products are correctly installed.

## User Tips



TECH TIPS

### 1. Selecting Additional Speaker Pairs with PSBs

The number of speakers per product group that can play at once is limited by the way you set the speaker limit on the 980 module. The Access™ System is capable of playing up to four pairs at once, but many amplifiers are not recommended to play more than one pair simultaneously. Read each amp's documentation to determine the setting you should use.

- To add a pair of speakers to the pair currently playing, “Long Press” the PSB (press and hold about one second) for the additional pair you wish to add until both pairs are playing.
- To turn any current speaker selection OFF, press its PSB.
- A short press on a new speaker selection cancels all previous selections.

### 2. Deselecting Products with PSBs

Turn any currently selected product OFF by pressing its PSB. The button light goes OFF. If you deselect an in-line product, such as an EQ, that product is replaced by a direct signal path if you have installed a bypass (for more information, see “bypass” in the index.)

### 3. A/B System Comparison

- A/B comparison may be performed on the 903i or 906 control panels. For detailed instructions, refer to the control panel User's Guide.
- When you switch a component such as a source, the Access System (configured with a 980 System module) engages our exclusive SilenTouch™ circuit to mute the audio level briefly (for a fraction of a second) during the switching process. This feature reduces switching noise.

**Notes:**

**Notes:**



# Reference

## Appendix A: Sample Systems

### Multi-Product Group Systems

- 34 Stereo System with 903i Control Panel
- 35 Home Theater System with 903i Control Panel

### Single Product Group Systems

- 36 A-V Source System with 906 Control Panel
- 36 Home Theater Speaker Package System with 906 Control Panel
- 37 Soundbar Demonstration System with 906 Control Panel
- 37 Soundbar and A-V Receiver Demonstration System with 906 Control Panel

## Appendix B: Product Connection Diagrams

- 38 Audio/Video Source Hookup (Model 955)
- 39 Stereo Source Hookup (Model 922)
- 40 Stereo Equalizer and DAC Hookup (Model 922, Model 956B)
- 41 System Module Hookup (Model 980)
- 42 Stereo Receiver Hookup (Model 942)
- 43 Digital Audio Hookup (Model 956B) and Low-level Subwoofer Hookup (Model 922)
- 44 Surround Receiver Hookup (Model 945)
- 45 Left and Right Speaker Hookup (Model 932)

# Appendix A: Sample Systems

These samples can help you in addressing and laying out your system as well as installing the buses and products. Pick a sample that is similar to your overall system and then ignore any parts that are not applicable. For example, if your system does not have a control panel, you can still use a sample system layout for comparison. If your system is stereo only, the connections and addressing scheme is very similar. There are also many drawings available showing unique product hookups and configurations. If you have any questions, or simply want to verify your system plans or product hookups, don't hesitate to call technical support at 800-322-8346 (800-32-AUDIO).

## Sample 2-Channel Audio System

- 903i Control Panel; PSBs are optional (not shown).
- 8 Stereo Sources.
- 3 Stereo Processors with Bypass.
- 8 Stereo Receivers with left/right audio input.
- 1 Stereo Speaker Pairs.

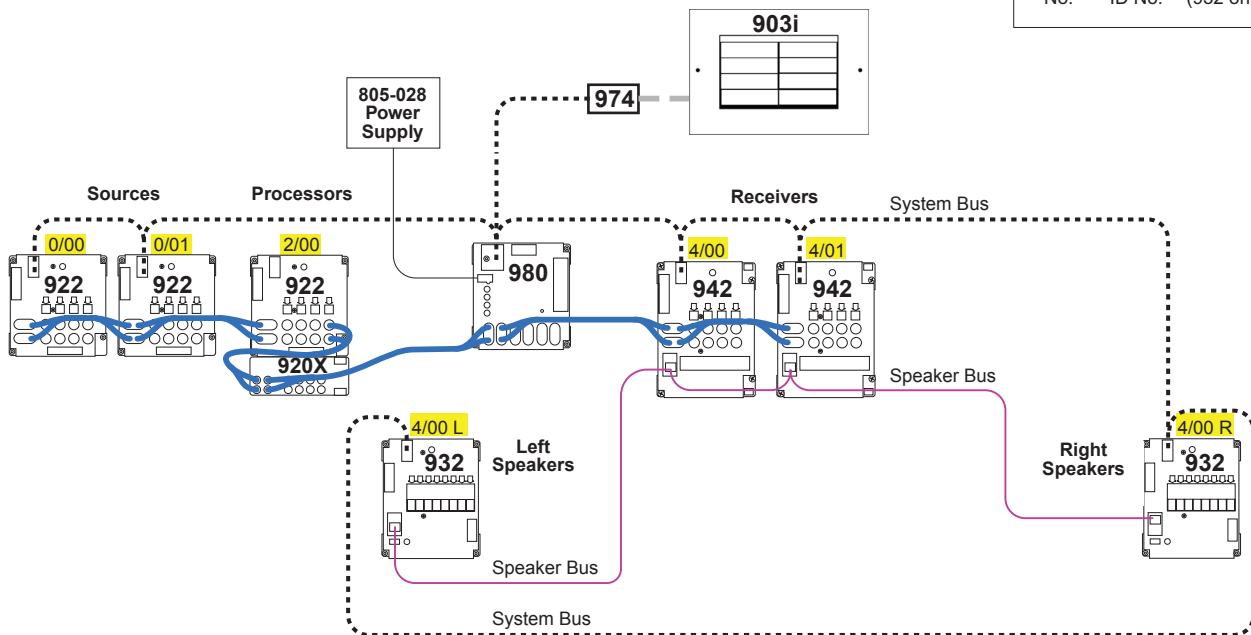
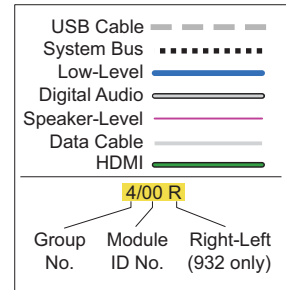

TECH TIPS

Audio Authority Tech Support USA and Canada: **800-322-8346** (Mon-Fri 8:30 AM to 5:00 PM Eastern Time)  
 Phone: 859-233-4599 Fax: 859-233-4510 Hookup drawings and FAQ [audioauthority.com/access\\_tips](http://audioauthority.com/access_tips)

## Sample Home Theater Atmos System

- 903i Control Panel; PSBs are optional (not shown).
- 8 Surround A-V Sources including digital audio output.
- 12 Surround A-V Receivers with optical digital audio input, coax digital audio input, and low-level sub out.
- 6 Speaker Groups: 16 Front pairs, 8 Center speakers, 8 Surround pairs, 8 Side pairs, 8 Front Ceiling pairs, 8 Rear Ceiling pairs, and 4 Powered Subwoofers.

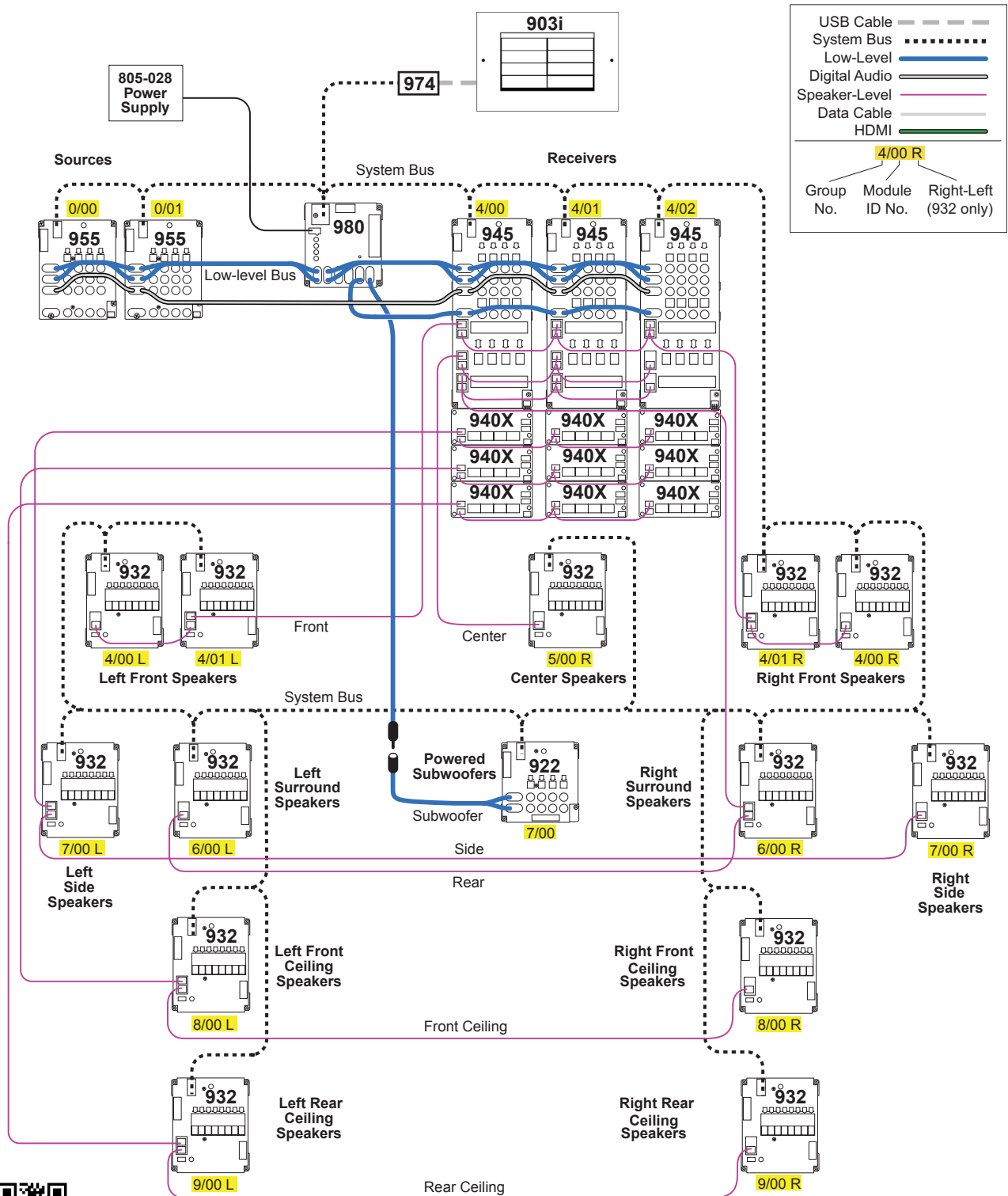

TECH TIPS

Audio Authority Tech Support USA and Canada: **800-322-8346** (Mon-Fri 8:30 AM to 5:00 PM Eastern Time)  
 Phone: 859-233-4599 Fax: 859-233-4510 Hookup drawings and FAQ [audioauthority.com/access\\_tips](http://audioauthority.com/access_tips)

## Sample A-V Source System

- 906 Control Panel. PSBs are optional (not shown).
- Dedicated home theater receiver and speaker package for audio output.
- Dedicated Video Monitor.

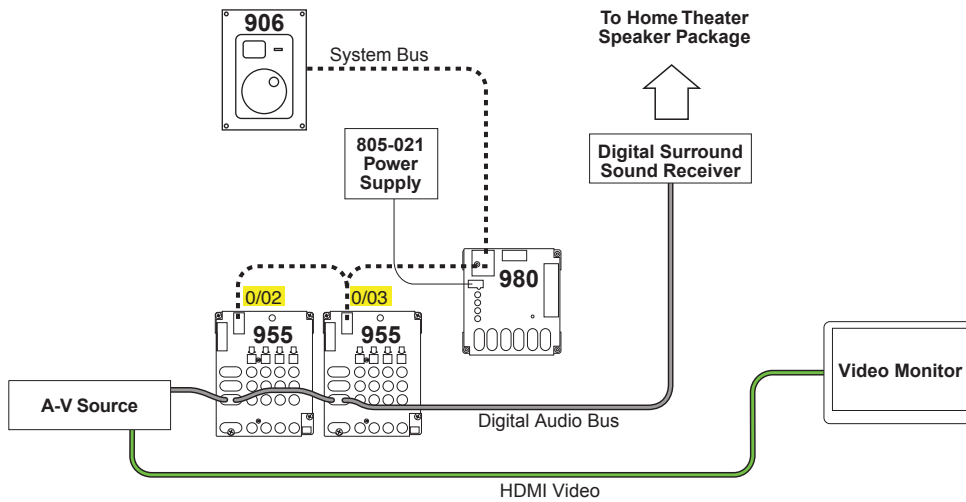

## Sample Home Theater Speaker Package System

- 906 Control Panel. PSBs are optional (not shown).
- Dedicated A-V Source with digital audio output and Surround Receiver.
- 8 Speaker Packages including Front, Center, Rear and Sub channels.
- Dedicated Video Monitor.

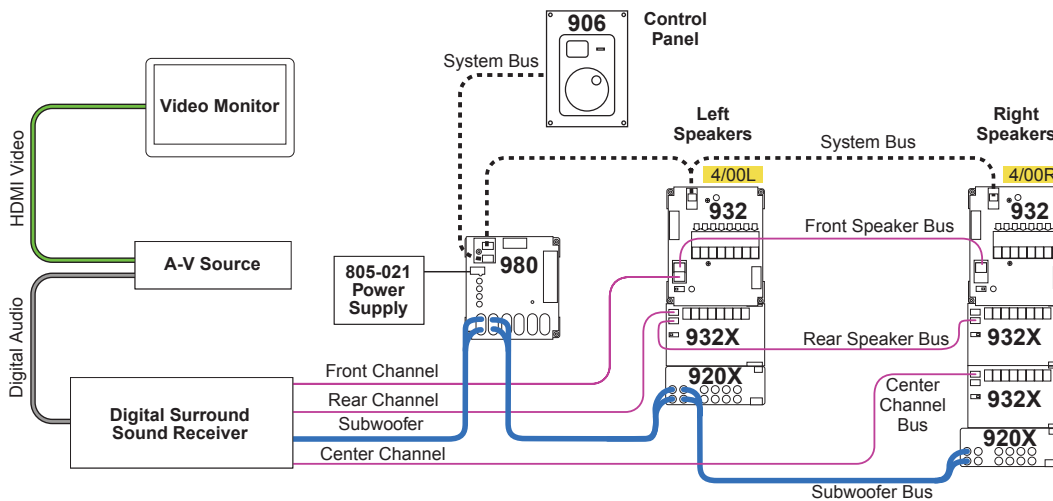
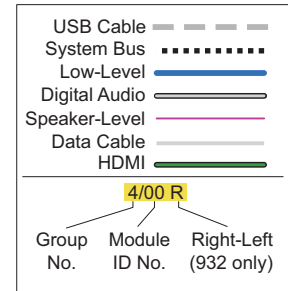

TECH TIPS

Audio Authority Tech Support USA and Canada: **800-322-8346** (Mon-Fri 8:30 AM to 5:00 PM Eastern Time)  
 Phone: 859-233-4599 Fax: 859-233-4510 Hookup drawings and FAQ [audioauthority.com/access\\_tips](http://audioauthority.com/access_tips)

## Sample Soundbar Demo System

- 906 Control Panel; PSBs are optional (not shown).
- 1 Digital A-V Source.
- 8 Soundbars.
- Dedicated Video Monitor.

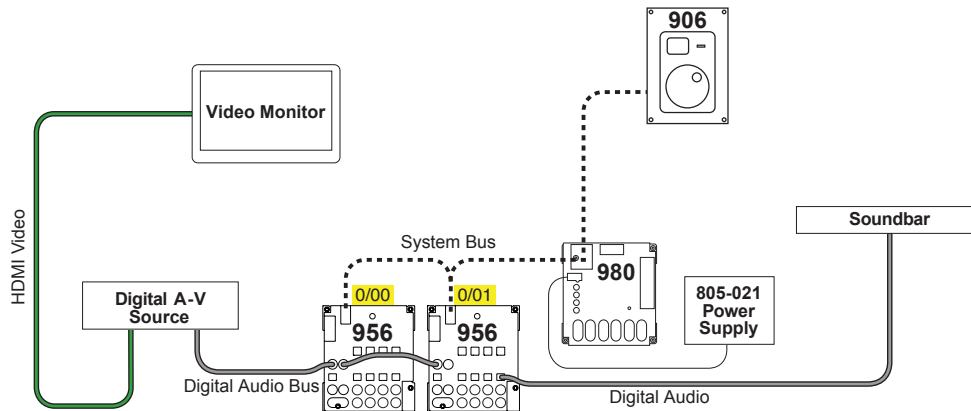

**Note:** Do not use the optical source input in this application because it does not travel over the coaxial bus.

## Sample Soundbar and A-V Receiver Demo System

- 906 Control Panel; PSBs are optional (not shown).
- 1 Digital A-V Source.
- 4 Soundbars.
- 4 A-V Receivers.
- Dedicated Video Monitor.

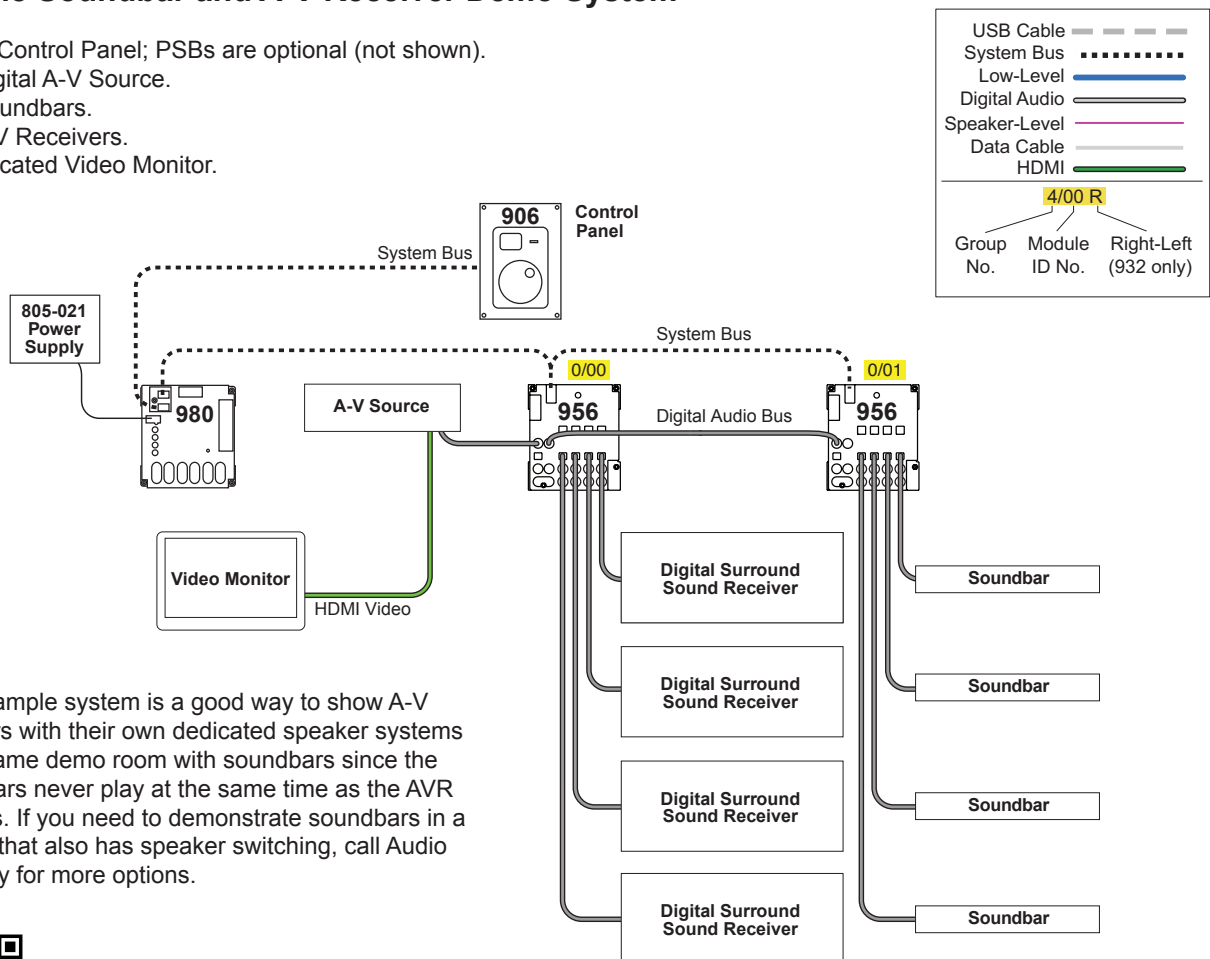

This example system is a good way to show A-V receivers with their own dedicated speaker systems in the same demo room with soundbars since the soundbars never play at the same time as the AVR systems. If you need to demonstrate soundbars in a system that also has speaker switching, call Audio Authority for more options.



TECH TIPS

Audio Authority Tech Support USA and Canada: **800-322-8346** (Mon-Fri 8:30 AM to 5:00 PM Eastern Time)  
 Phone: 859-233-4599 Fax: 859-233-4510 Hookup drawings and FAQ [audioauthority.com/access\\_tips](http://audioauthority.com/access_tips)

## Appendix B: Product Connection Diagrams

The examples in the following pages focus on the basic connections for specific home audio and video products. In some cases, other variations are possible, and other drawings are available from your Audio Authority® Account Manager.

### Audio Video Source

This layout shows an A-V source switched with the 955 module. Most sources will use only one digital audio output. There is no optical digital connection on the 955, use a coax output from digital audio sources, or use the 977R Optical to Coax Adapter. Instructions for other types of Surround or Dolby Digital configurations are available if needed. Contact your Account Manager at 800-322-8346.

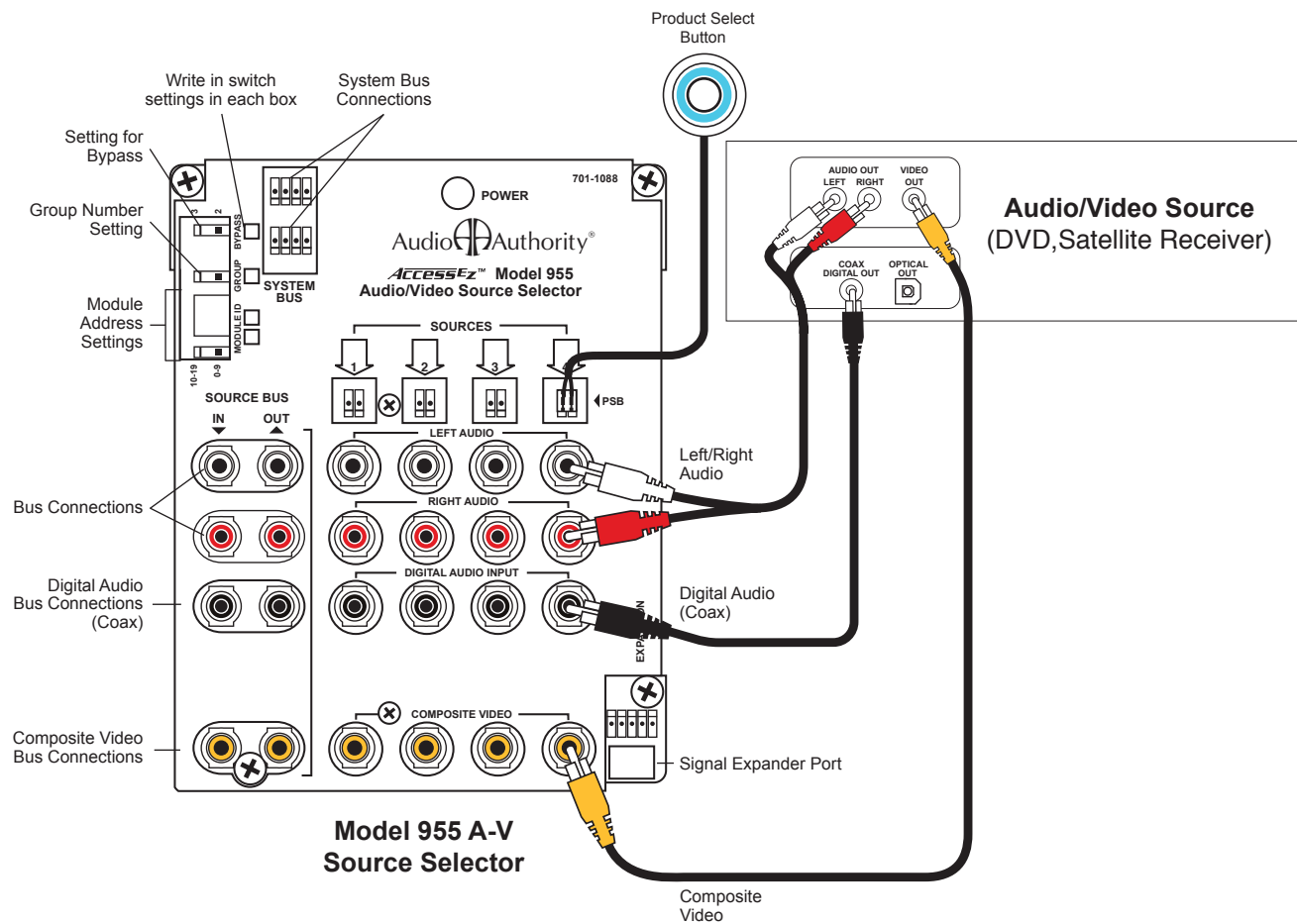

TECH TIPS

Audio Authority Tech Support USA and Canada: **800-322-8346** (Mon-Fri 8:30 AM to 5:00 PM Eastern Time)  
 Phone: 859-233-4599 Fax: 859-233-4510 Hookup drawings and FAQ [audioauthority.com/access\\_tips](http://audioauthority.com/access_tips)

## Stereo Sources

This drawing shows a stereo source switched with the 922 module. For A-V sources, use the Model 945. For instructions regarding low-level subwoofers, see the appendix drawing for Subwoofers. Instructions for other types of stereo groups are available if needed. Contact your Account Manager at 800-322-8346.

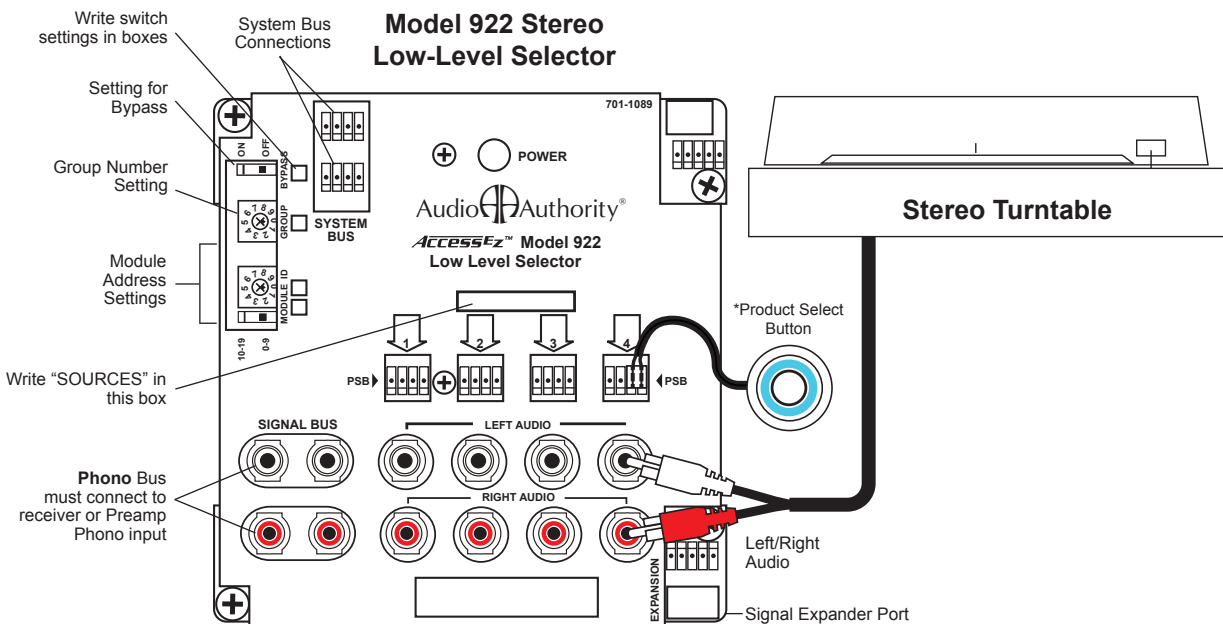
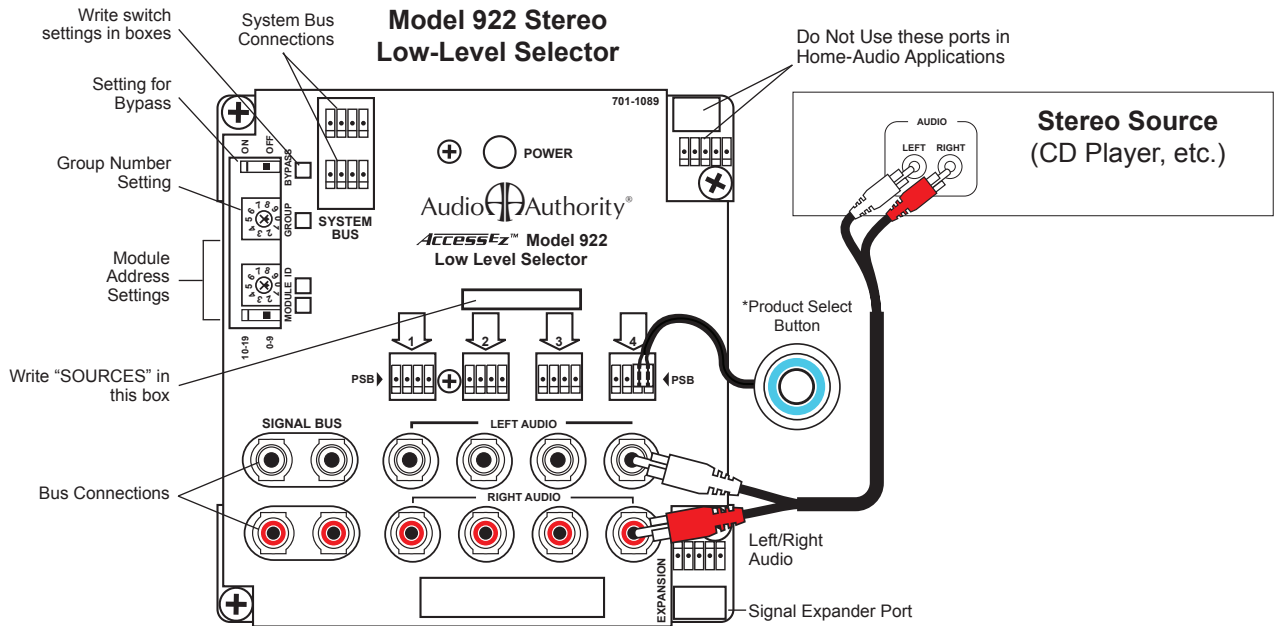

\*2-wire or 4-wire PSBs may be used. See page 25 for more information



TECH TIPS

Audio Authority Tech Support USA and Canada: **800-322-8346** (Mon-Fri 8:30 AM to 5:00 PM Eastern Time)  
Phone: 859-233-4599 Fax: 859-233-4510 Hookup drawings and FAQ [audioauthority.com/access\\_tips](http://audioauthority.com/access_tips)

## Equalizers and DACs

The top drawing shows Equalizer Product Groups. The lower drawing shows a Digital Audio Converter (DAC). Instructions for other types of stereo groups are available if needed. Contact your Account Manager at 800-322-8346.

\*2-wire or 4-wire PSBs may be used. See page 25 for more information

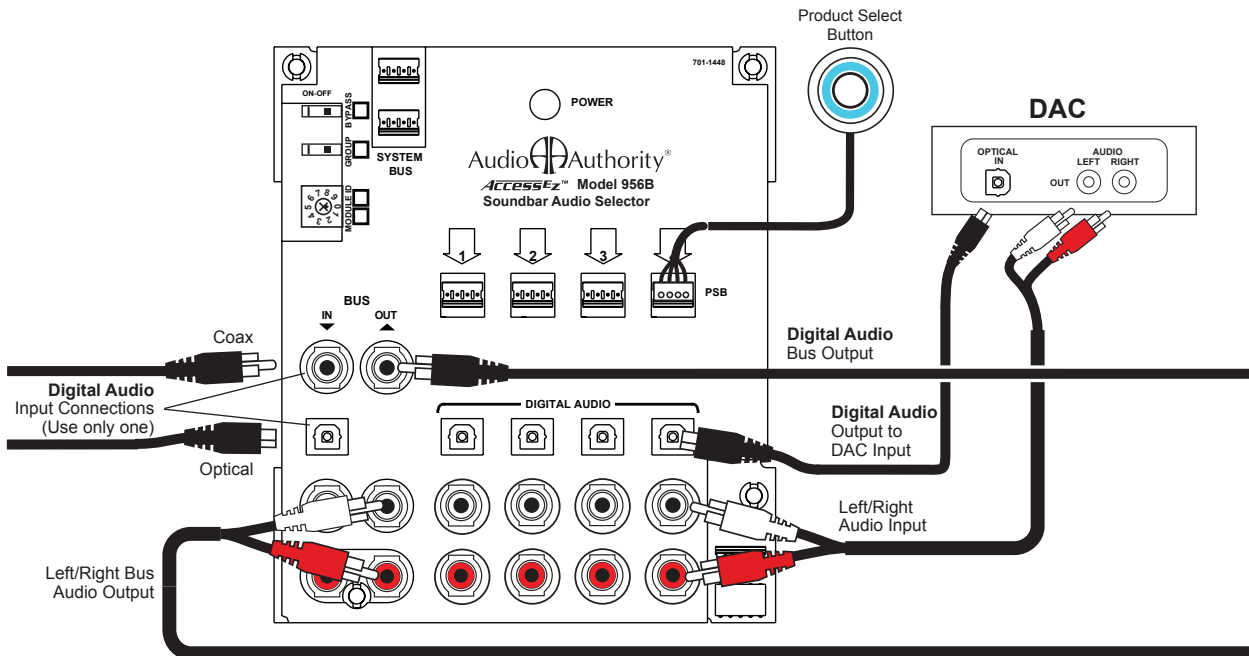
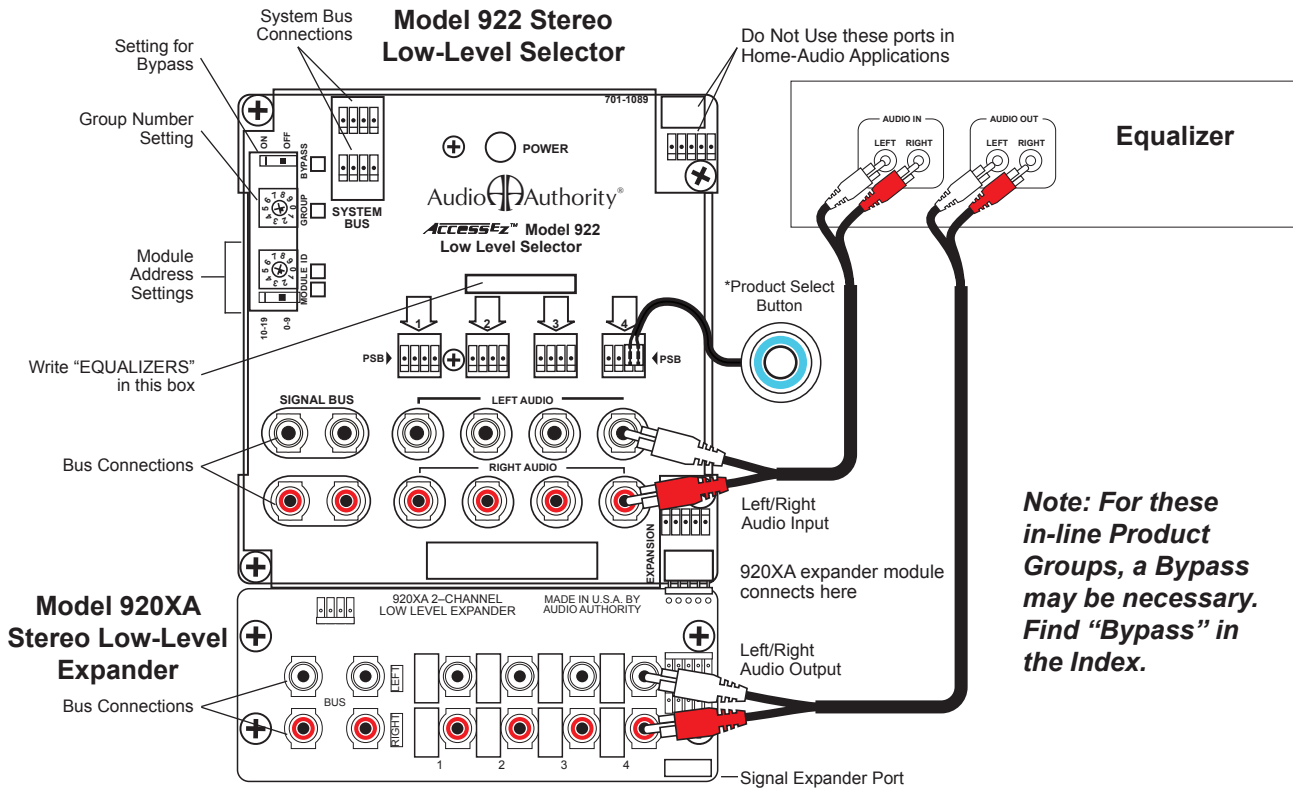

Audio Authority Tech Support USA and Canada: **800-322-8346** (Mon-Fri 8:30 AM to 5:00 PM Eastern Time)  
 Phone: 859-233-4599 Fax: 859-233-4510 Hookup drawings and FAQ [audioauthority.com/access\\_tips](http://audioauthority.com/access_tips)



## Model 980B System Module

In addition to SilenTouch™, the 980 performs several other system functions, and provides a connection point for Control Panels and system power.

Concerning signal path, the Model 980 will be located just before the Receiver Product Group in the Left/Right Analog Audio Bus. Do not connect any digital audio or video cables to the 980. In this configuration, the Front Inputs and Front Outputs are the only Low-Level connections that are used.

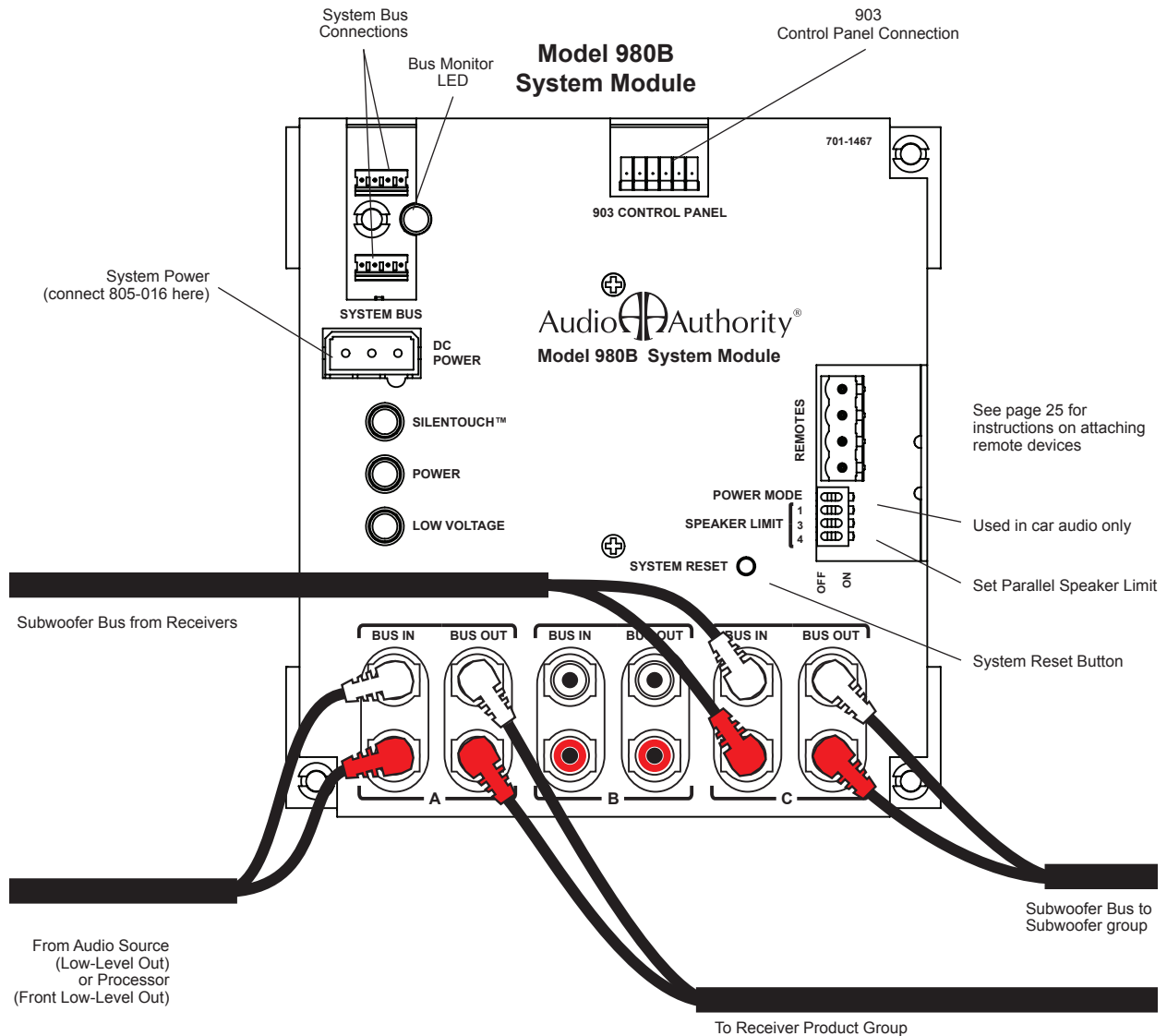

TECH TIPS

Audio Authority Tech Support USA and Canada: **800-322-8346** (Mon-Fri 8:30 AM to 5:00 PM Eastern Time)  
 Phone: 859-233-4599 Fax: 859-233-4510 Hookup drawings and FAQ [audioauthority.com/access\\_tips](http://audioauthority.com/access_tips)

## Stereo Receiver

This diagram shows connections to two-channel receivers or amplifiers. To demonstrate receivers with more than two channels, see the drawing for Dolby Digital™ and ProLogic™ Receivers. Instructions for other types of two-channel receiver or amplifier configurations are available if needed. Contact your Account Manager at 800-322-8346.

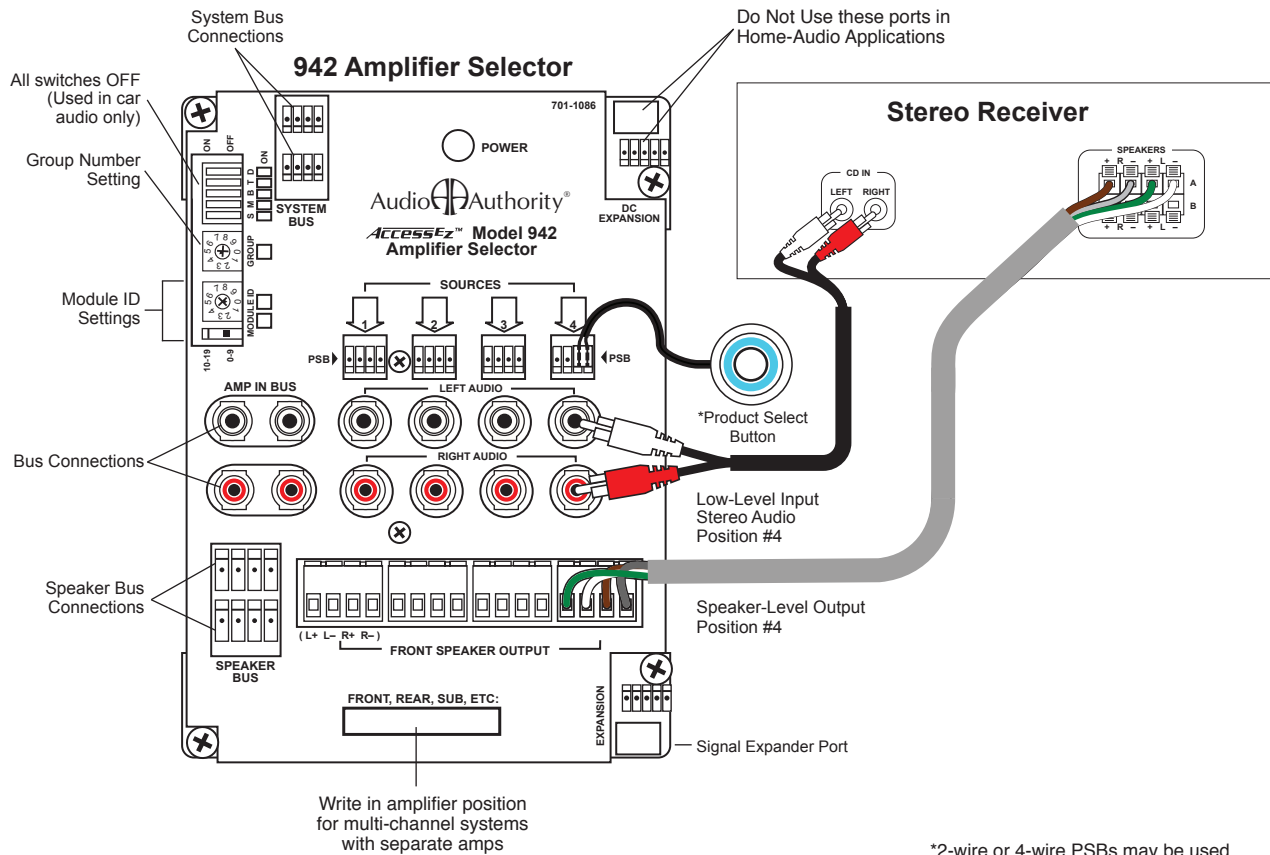

\*2-wire or 4-wire PSBs may be used. See page 25 for more information

Wire Color Code	
Green L+	Brown R+
White L-	Gray R-



TECH TIPS

Audio Authority Tech Support USA and Canada: **800-322-8346** (Mon-Fri 8:30 AM to 5:00 PM Eastern Time)  
 Phone: 859-233-4599 Fax: 859-233-4510 Hookup drawings and FAQ [audioauthority.com/access\\_tips](http://audioauthority.com/access_tips)

## Soundbar Audio Demo

This diagram shows connections for the Access 956B Soundbar Audio Selector. The 956B audio inputs connect with either analog stereo jacks or optical cables to the Soundbar demonstration units. Instructions for other types of configurations are available if needed. Contact your Account Manager at 800-322-8346.

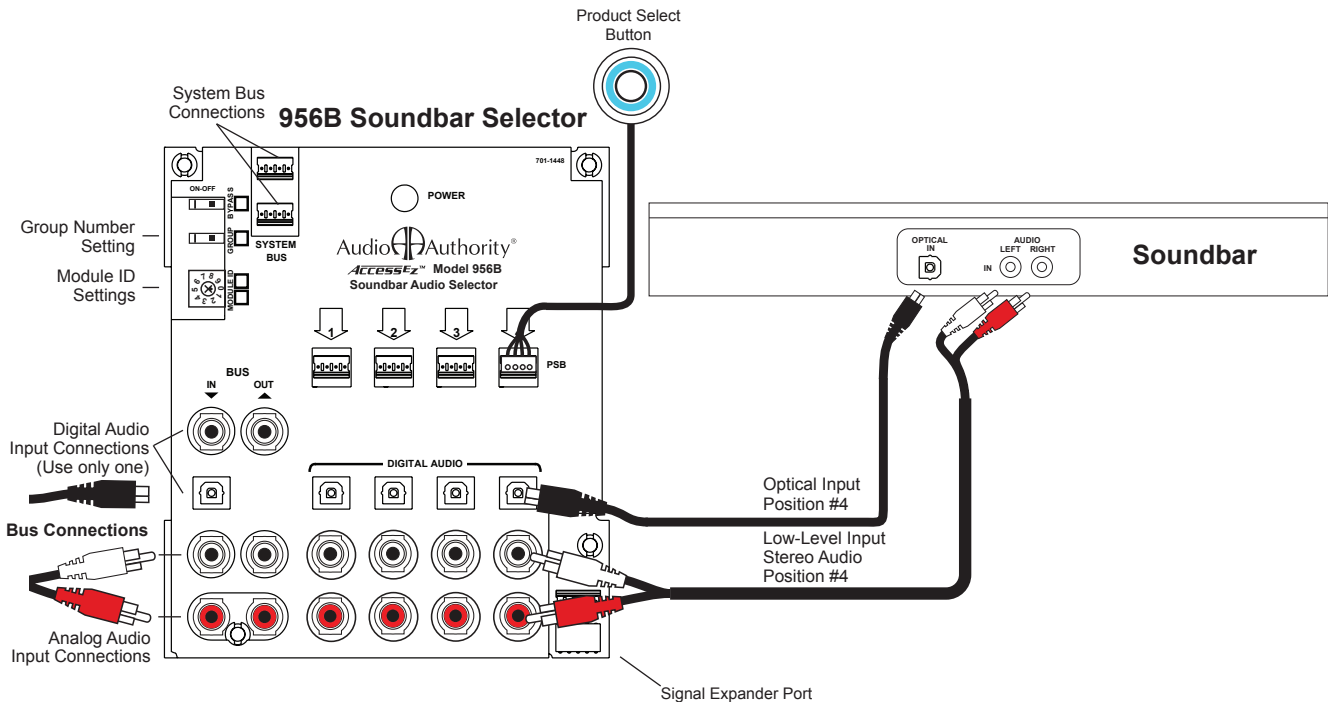

## Low-Level Subwoofers

This drawing shows a powered subwoofer switched by a 922 Low-Level Selector. The Group address should be higher than the highest speaker Group address. The mono subwoofer bus cable connects to the stereo jacks with a "Y" adapter. Instructions for other types of subwoofer configurations are available if needed. Contact your Audio Authority® account manager at 800-322-8346.

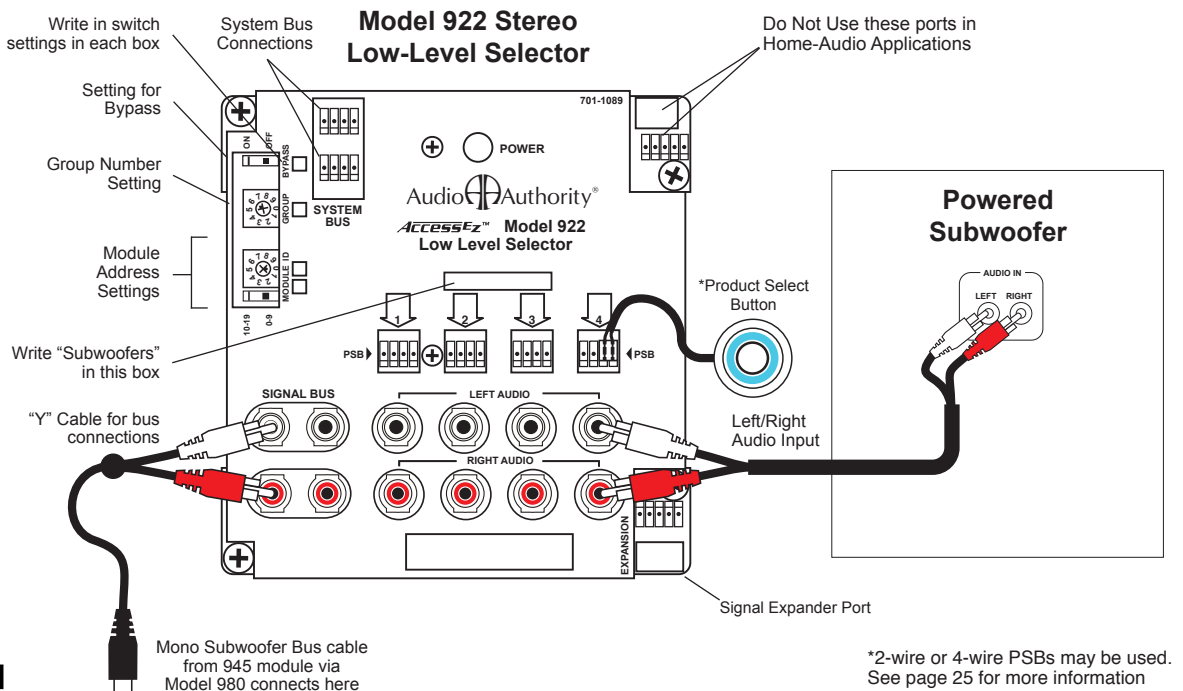

TECH TIPS

Audio Authority Tech Support USA and Canada: **800-322-8346** (Mon-Fri 8:30 AM to 5:00 PM Eastern Time)  
 Phone: 859-233-4599 Fax: 859-233-4510 Hookup drawings and FAQ [audioauthority.com/access\\_tips](http://audioauthority.com/access_tips)

## 5.1 Channel Surround Sound

This diagram shows connections to receivers with analog audio outputs, digital audio inputs, and a low-level sub out jack. If a receiver does not have some of the features shown, simply leave those jacks or terminals vacant on the 945. Instructions for other types of surround sound configurations are available if needed. Contact your Audio Authority® account manager at 800-322-8346.

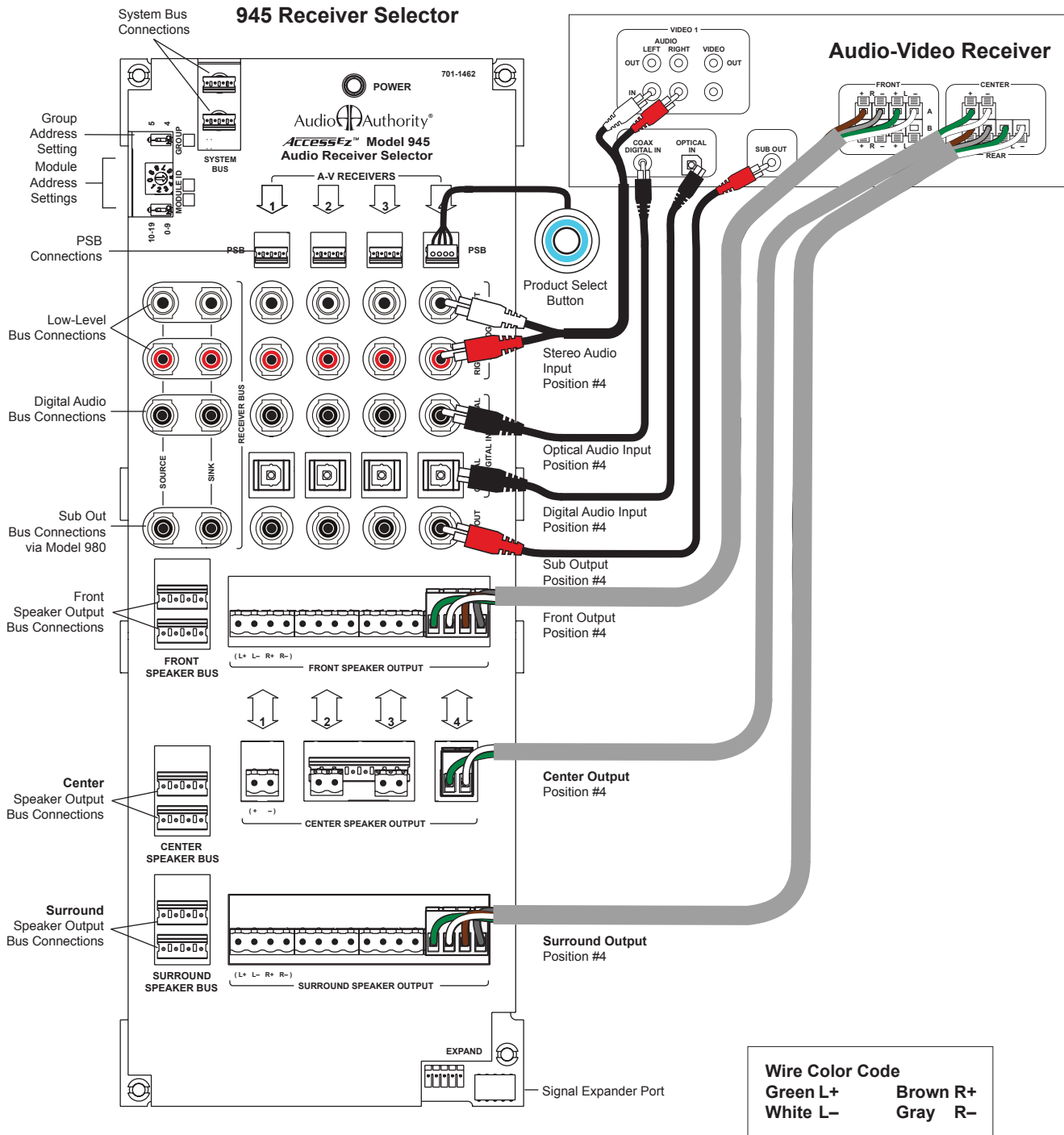

TECH TIPS

Audio Authority Tech Support USA and Canada: **800-322-8346** (Mon-Fri 8:30 AM to 5:00 PM Eastern Time)  
Phone: 859-233-4599 Fax: 859-233-4510 Hookup drawings and FAQ [audioauthority.com/access\\_tips](http://audioauthority.com/access_tips)

## Left & Right Speakers

Model 932 Speaker Modules can be configured to function as left, right or mono modules. The slide switch on the bottom left side of the module is marked "Left-Right." Position the switch to "Left" for left channel function and "Right" for either right channel or mono function (if used for mono operation there will not be a corresponding "L" module.)

932 modules in the Front Speaker Product Group are unique in the fact that they share the same Group Address with the receiver group. For example, if the Receiver Product Group number is "4", then the Front Speaker Group number would also be "4". All other speaker groups should have a higher Group address.

Left and Right modules have the same Module ID (e.g. for front speakers 1-8 both Left & Right modules would be addressed: Module ID= "0-9" on the slide switch, and "0" on the rotary switch; Group= 4.

The next module pair for front speakers 9-16 both Left & Right modules would be addressed: Module ID= "0-9" on the slide switch, and "1" on the rotary switch; Group= 4, etc.)

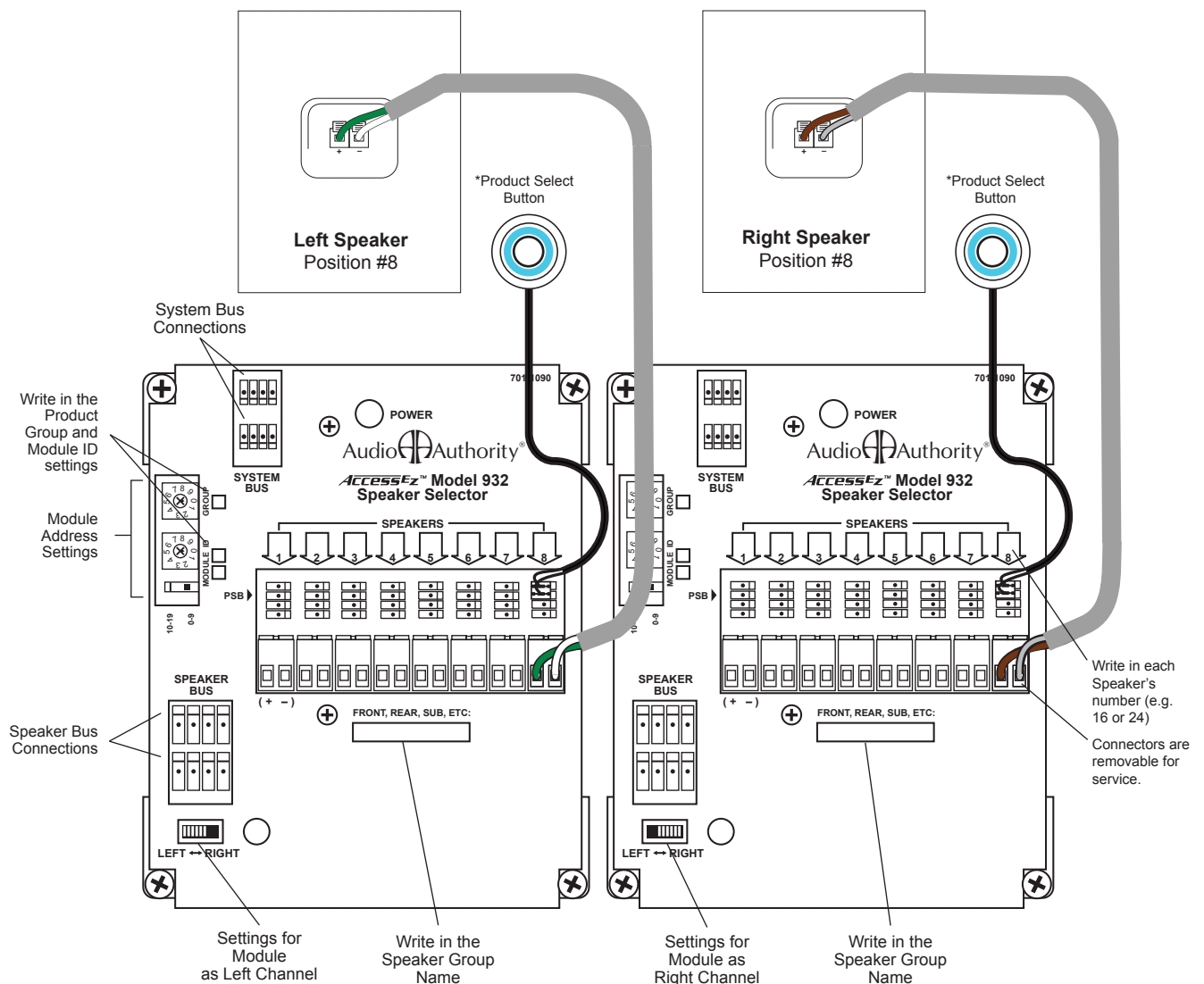

\*2-wire or 4-wire PSBs may be used.  
See page 25 for more information

Wire Color Code	
Green L+	Brown R+
White L-	Gray R-



TECH TIPS

Audio Authority Tech Support USA and Canada: **800-322-8346** (Mon-Fri 8:30 AM to 5:00 PM Eastern Time)  
Phone: 859-233-4599 Fax: 859-233-4510 Hookup drawings and FAQ [audioauthority.com/access\\_tips](http://audioauthority.com/access_tips)

## **Definition of Terms**

To successfully install your new *Access Demonstration Network*, you should familiarize yourself with the following terms:

- Address** A number that pinpoints the identity and location of a switch module within that system. The installer sets numeric switches like the ones in *Figure 26* on page 17 for each module that provides a unique address in the proper sequence for each component connected to the system.
- AutoDamping™** When merchandising many pairs of different speakers in a showroom, the drivers of the unselected speaker pairs become passive radiators when the currently active speaker pair is playing, absorbing much of the sound coming from the speakers being played. AutoDamping™ is a circuit in the Model 932 and 939 that electrically disconnects (shorts) speakers not being played, thereby automatically damping them as passive radiators and improving sound quality in the showroom.
- Bus** A Bus is a pathway for signals to travel from module to module; a cable connecting modules. There are three types of buses found in most Access Systems:
- **System Bus** A four wire harness (red, black, yellow, blue) connected to every Access module. The System Bus carries the signals that control the selection of the components and perform various housekeeping functions among the modules in the system.
  - **Speaker Bus (or High-level Bus)** A four wire harness (green, white, brown, gray) that carries speaker-level signals from source and/or amplifier modules to speaker modules.
  - **Low-level Bus** A signal bus using RCA patch cables to carry low-level audio signals between source modules and equalizer or amplifier modules.
- Bypass** A way to hear a system without a particular in-line component (EQ, Crossover, Amplifier, etc.) For example, when you wish to hear a system without the processor, the system can route the signal past the processor group and directly to the amplifiers. In this example, Position #4 on the last module in the Processor Product Group is used as the bypass location. When this position is selected, or the bypassed Product Group is deselected, the audio signal continues through the bypassed group to the next Product Group. To activate Bypass, find the last 922 module in the Processor group and turn on its Bypass switch.
- Control Panel** Control Panels, like the 903i or 906, add central control and display capabilities to a system. Any control panel can operate hand-in-hand with product select buttons.

<b>Module</b>	<p>A basic component of the Access™ System. There are five types of modules normally found in home entertainment applications:</p> <ul style="list-style-type: none"> <li>• <b>Switching Modules or Product Selector Modules</b> select and connect products for demonstration and communicate with other system components through the System Bus. Examples are Models 922, 932, 942, 945 955 and 956B.</li> <li>• <b>Expander Modules</b> add channel capacity to switching modules. Examples are Models 920X and 940X.</li> <li>• <b>System Module (Model 980)</b> performs basic control, interface and housekeeping functions within the system.</li> <li>• <b>Control Modules</b> - Examples are Models 970A, 1322D</li> <li>• <b>Adapters and Converters</b> - Examples are 977 and 979</li> </ul>
<b>Position</b>	<p>The numbered point of connection (1-4 for electronics, or 1-8 for speakers) of a product to a switching or expander module. The product select button (PSB) must be connected to the corresponding position on the module. For example, if a component is connected to position 3, its product select button must be connected to PSB position 3. When a “bypass” is required, always use the fourth position (see “bypass”.) Control Panels select positions through the System Bus, and are not connected to individual positions.</p>
<b>Product Group</b>	<p>A group of functionally similar products, such as head units, amplifiers, subwoofers, etc.</p>
<b>Product Select Button (PSB)</b>	<p>A push-button mounted at, or near the product location. Pushing this button selects the product for demonstration and lights an LED to confirm the selection.</p>
<b>System</b>	<ol style="list-style-type: none"> <li>1. A network of switching modules interconnected by buses where a control panel and/or PSBs are employed to select and thereby interconnect specific components for demonstration.</li> <li>2. A configuration of audio products or components playing together which can be stored in control panel memory and A/B compared with other “systems”.</li> </ol>
<b>SilenTouch™</b>	<p>SilenTouch mutes the sound for a brief period during the switching process to eliminate transient noises while changing from one product to the next.</p>

# Access™ Warranty

## Limited Warranty

If an Access™ product becomes defective in materials or workmanship within three years from the date of purchase, Audio Authority® Corporation guarantees to the original purchaser that it will repair or replace the defective product at no cost. This is a limited warranty and is not applicable for products that in our sole opinion have been damaged (e.g. lightning, water, fire), altered, abused, misused, or improperly installed. Audio Authority makes no other warranties, expressed or implied, including warranties as to merchantability or fitness for a particular purpose. Additionally, there are no allowances or credits available for repair service work or installations performed by, or on behalf of, the end user.

## Warranty Service Procedures

Should an Audio Authority® product fail to function as designed within the warranty period, the unit will be repaired or replaced. If you suspect a product failure, please contact our Technical Support staff at **800-322-8346** or **859-233-4599**, or alternatively by email at [support@audioauthority.com](mailto:support@audioauthority.com) during normal business hours. Our staff will make every effort to help you get the failed product working. Often, we are able to resolve the problem through this troubleshooting effort. When you call or write the factory, please be ready with the invoice number, product model and serial number, along with the nature of the problem. If it is determined that the product needs to be repaired or replaced, a Return Authorization Number (CR#) will be issued for return to the factory, freight prepaid. You may select one of two service options detailed below –Repair & Return, or Service-Exchange.

### Repair and Return

Once the product is received at our factory, it will be repaired to full working order and returned promptly to you at no charge using Ground transport services. Other methods of shipment are available, but at your expense. If we determine the product's failure was due to circumstances other than defects in materials or workmanship (damage), the transaction will be treated as Out-of-Warranty Service and you will be contacted by Technical Support with an estimate for the repair.

### Service-Exchange

You will be charged (invoiced) a security deposit equal to the normal price of the replacement product shipped using a major credit card or on open account terms, if those terms have been established. We will pay the shipping charges for exchange items using Ground transport services. Any other method of shipment will be charged to the customer. You will then be responsible to return the failed item to the factory freight prepaid along with all accessories included. Please be certain to mark the Return Authorization Number (CR#) on the outside of the carton you are returning for prompt processing. Your return must be received at the factory within Thirty (30) Days for reimbursement of the security deposit originally charged to your credit card or for a credit to be issued to your established open account. If we determine the product's failure was due to circumstances other than defects in materials or workmanship (damage), the transaction will be treated as an Out-of-Warranty Service exchange.

### Out of Warranty Service

Audio Authority® products that fail after the warranty period has expired may be returned to the factory for repair at a nominal charge, if not damaged beyond the point of repair. Most Audio Authority products may be repaired by the factory at our current, published Service Fee. Additionally, we also offer a limited Field Exchange program to service out-of-warranty products.

For future reference, please record below:

Date of Purchase: \_\_\_/\_\_\_/\_\_\_

Invoice No: \_\_\_\_\_



# Index

## Product Numbers

903i Comparator in example wiring diagram...34  
903i Comparator...6  
903i Comparator installation...23  
903i Polling...16  
906 Control Panel...6  
906 Control Panel installation...23  
920X Low-Level Expansion Module...18  
922 Speaker Module hookup diagram...43  
932 Speaker Selector...8  
932 Speaker Module hookup diagram...45  
932X Expander Module...7  
940X High-Level Expander Module...7  
942 Modules...19  
942 Module hookup diagram...42  
945 Module hookup diagram...44  
955 Module hookup diagram...38  
956 Module hookup diagram...43  
974 RS232 to USB Interface...7  
977 Digital Audio Adapters...7  
980 Module and control panel installation...23  
980 Module hookup diagram...41  
980 System Module Accessories...25  
980 System Module and DC power...26  
980 System Module location...18  
980 System Module...7

## A

A/B System Comparison...31  
Add a pair of speakers with PSBs...31  
Additional Speaker Pairs...31  
Address and Other Settings...15  
Amplifier Bypass switch settings...17  
Amplifier hookup diagram...42  
AutoDamping™...8

## B

Bus cable installation...18  
Bus, definition of...5  
Bus extension cables...18  
Bus fabrication...19  
Bus Monitor LED on 980...26  
Bypass and programming switches...17  
Bypass, definition of...46

## C

Comparing A/B systems...31  
Components of the Access™ System...6  
Computer for product selection...5  
Connector polarity...21  
Control panel cut-out sizes...23  
Control Panel, definition of...46  
Control Panel installation...23  
Control Panel testing...26

Control Panel to select products...6  
Control Panels...6

## D

Demo Product Installation...29  
Deselecting Products with PSBs...31  
Digital Audio Adapters...7  
DIP switches...17  
Duplicate addresses...27

## E

EQ hookup diagram...40  
Expansion ports...18

## G

Green/white/brown gray cable...19

## H

Hardware installation...15  
High-level Bus (Speaker Bus)...19

## I

Identification boxes...17  
Install the first products...29  
Installing the bus cables...18  
Install the Remaining Products...30  
Installing the System Hardware...15  
Installing Product Select Buttons...28

## L

Left-Right switch...17  
Left-Right switch and Model 932...17  
Left/Right Speaker Hookup...45  
Low Voltage LED...26  
Low-capacitance RCA patch cables...15  
Low-level Bus...20  
Low-level bus example...5  
Low-Level Bus example wiring diagram...34  
Low-Level Bus installation...20  
Low-level signal...5

## M

Model 980 4-Channel hookup...41  
Module count on 903...27  
Module, definition of...47  
Module ID and address settings...15  
Module ID settings...16  
Mono Subwoofer Hookup and addressing...35  
Multiple speaker pair selection...31

Multiple speaker pairs in parallel...31

## N

Numbering the Product Groups...15

## O

Open or vacant headers...19  
Optical Digital Audio Adapters...7

## P

Parallel Speaker Limit settings...28  
Position 4. See Bypass Position, definition of...46  
Power LED...26  
Product Group, definition of...47  
Product Groups and the 903i...16  
Product Select Button installation...28  
Product Select Button testing...28  
Product Select Buttons...5  
Product selection...5  
Programming Switches on the 906...23  
PSB...5. See also Product Select Button PSB, definition of...47

## R

RCA patch cords...18  
RCA patch cords and Low-Level Bus...20  
Remote Power Switch...25  
Remotes terminal block on 980...25  
RS232 to USB Interface...6

## S

Sample wiring diagram...34  
Selecting Products...5  
Signal Buses, different types...5  
SilenTouch, definition of...47  
SilenTouch LED and normal operation...26  
Software version...26  
Source Bus installation...20  
Source selector...7  
Speaker Bus...19. See also Speaker Bus Installation  
Speaker Bus example wiring diagram...11  
Speaker Bus installation...19  
Speaker extension...19  
Speaker Hookup...45  
Speaker Limit...28  
Speaker Limit settings...31  
Speaker Module addressing...17

- Speaker selector...8
- SPST (single-pole, single-throw) switch...25
- Stereo switching system...10
- Switch Settings S M B T D...17
- Switching Modules, definition of...47
- System Bus...19
- System Bus, definition of...47
- System Bus example wiring diagram...19, 34
- System bus extension...19
- System Bus Test...26
- System, definition of...47
- System extension...19
- System Modules, definition of...47
- System Reset and remote switches...25
- Systems Product Group...7

## **T**

- Test product selection with PSBs...30
- Testing initial product installation...30
- Testing Network Function...30
- Testing speaker limit...31
- Testing your system...26
- Tools and materials you will need...15

## **U**

- User Interfaces...6
- User Tips...31

## **V**

- Vacant headers...19

## **W**

- Warranty...48
- Wiring diagram for sample system...34

## **Y**

- Yellow/Red/Blue/Black cable...19





**Access™**

- Tips
- Examples
- FAQ

[audioauthority.com/access\\_tips](http://audioauthority.com/access_tips)

# Audio Authority®

2048 Mercer Road, Lexington, Kentucky 40511-1071  
800-322-8346 • 859-233-4599 • Fax: 859-233-4510  
[www.audioauthority.com](http://www.audioauthority.com) • [support@audioauthority.com](mailto:support@audioauthority.com)

752-148C  
20170405