

INSTALLATION AND OPERATION

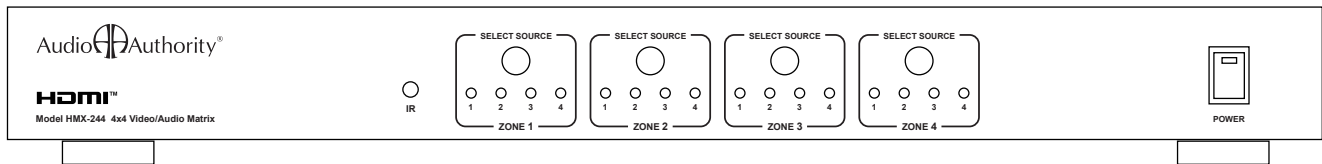

MODEL HMX-244 4-SOURCE / 4-ZONE MATRIX SWITCHING SYSTEM

Audio Authority®



Audio Authority and the Double-A Symbol are registered trademarks of Audio Authority Corp.

HDMI, the HDMI logo and High-Definition Multimedia Interface are trademarks or registered trademarks of HDMI Licensing LLC.

Audio Authority® Corporation Lexington, Kentucky
www.audioauthority.com • 800-322-8346 • 859-233-4599

Warnings

To reduce the risk of fire or electric shock, do not expose this unit to rain or moisture.



The exclamation point symbol alerts users to important operating and maintenance instructions in this booklet.

- Read this manual before installing or using this product.
- This product must be installed by qualified personnel.
- Do not open the cover—there are no user-serviceable parts inside.
- Do not expose this unit to excessive heat.
- Install only in dry, indoor locations.
- Do not obstruct the ventilation slots.
- Clean the unit only with a dry or slightly dampened soft cloth.

MODEL HMX-244

4-SOURCE / 4-ZONE MATRIX SWITCHING SYSTEM

1.0 INTRODUCTION

Thank you for purchasing this Model HMX-244 HDMI® Matrix Router from Audio Authority®. It is designed to route digital audio and video signals from four different HDMI sources to four HDMI displays without signal degradation or loss of encryption. All displays have access to any of the four sources connected to the HMX-244 at any time.

The HMX-244 also features an alternative output for each zone over two Cat 5e/6 cables, terminated by a zone receiver (Model 1380R, sold separately).

The HMX-244 is HDCP v1.1 compliant, and HDMI compliant, supporting HDMI 1.3 features including deep color video, Dolby TrueHD, and DTS-HD Master Audio.

Audio Authority offers an extensive line of audio and video switchers, converters, extenders and distribution amps available for purchase online at www.audioauthority.com.

1.1 FEATURES

- Delivers four HDMI source signals to any or all of four compatible video displays
- Optional Cat 5 zone receiver (Model 1380R) terminates dual Cat 5e/6 cables up to a maximum distance of 130 ft. (40m); recommended for runs over 50 ft. (15m)
- 1380R provides a built-in IR receiver that transmits IR commands from the zone to the HMX-244 to switch inputs and to pass IR commands to the sources
- Input switching can be performed through RS-232 or IR
- HDMI and HDCP compliant
- Supports deep color: 12 bits per TMDS channel (36 bit, sum of all channels)
- Supports 480i/p, 576i/p, 720p, 1080i/p and multiple PC resolutions
- Supports Dolby® Digital Plus, Dolby Digital TrueHD, DTS-HD: Master Audio, and LPCM
- IR remote control, RS-232 control, or front panel control

2.0 CHECKING PACKAGE CONTENTS

Before attempting to use this matrix router, please check the packaging and make certain the following items are contained in the shipping carton:

HMX-244 MATRIX UNIT

Each HMX-244 includes the following:

- HDMI matrix router
- IR remote control
- 5.5V (4A) DC power adapter
- Rack mount hardware
- User manual

1380R ZONE RECEIVER (SOLD SEPARATELY)

Each 1380R includes the following:

- 1380R Cat 5 zone receiver
- IR remote control
- 5V (2A) power adapter

Note: Please retain the original packing material and invoice in case you need to return the equipment. If you find any items are missing, contact Audio Authority immediately. Have the model number and invoice available for reference when you call.

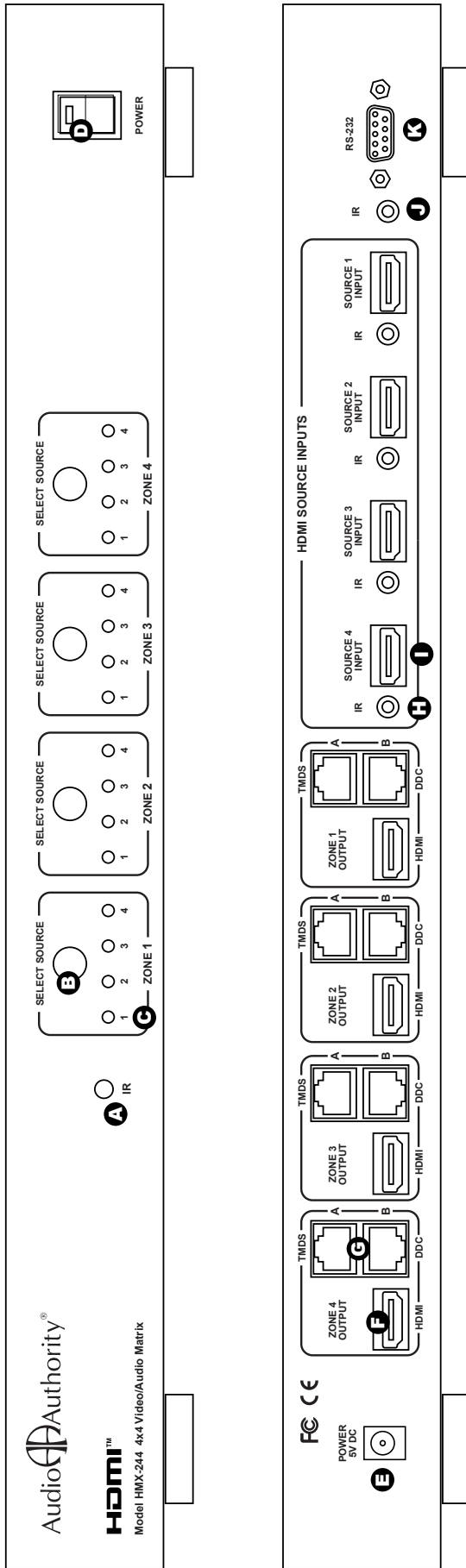

HMX-244 FRONT AND BACK PANELS

- A Infrared Receiver - accepts commands from IR remote controls
- B Source Selection Button - push button cycles through available source inputs
- C Selected Source Indicator Light - indicates the selected source in the specified zone
- D Power Switch - turns matrix off or on
- E Power Jack - connect included 5.5V, 4A power supply
- F HDMI Zone Output - connect directly to display and/or audio system in nearby zone
- G Cat 5 Zone Output - connect to Model 1380R zone receiver for long cable runs to more distant zone
- H Source IR Output Jack - repeats IR commands received by 1380R - connect IR emitter to source
- I HDMI input for source
- J IR Input Jack - connect Model 804-052 IR receiver (sold separately) for remote IR input
- K Serial Port - accepts RS-232 commands from home automation devices

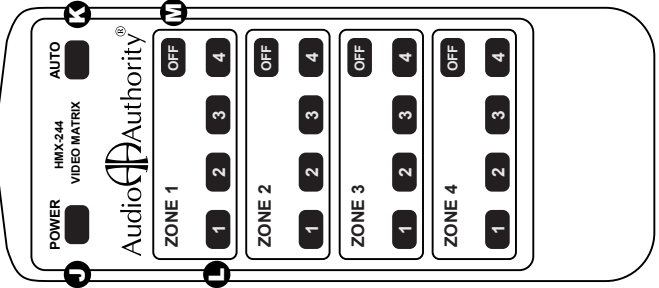

HMX-244 IR REMOTE

- J Power on/off button - turns matrix on or off
- K Auto mode - switches to lowest numbered output with video signal present
- L Source buttons for zone 1
- M Zone off button- disconnects all sources from zone IR emitter to source

1380R FRONT AND BACK PANELS

- A Infrared Receiver - accepts commands from IR remote controls
- B Power indicator light - shows power on or off status for zone receiver
- C Selected Source Indicator Light - indicates the selected source in the zone
- D Source Button - push to select source in this zone
- E Power Switch - turns zone receiver off or on
- F Power Jack - connect included 5V, 2A power supply
- G IR Input Jack - connect Model 804-052 IR receiver to send IR signals over Cat 5 to HMX-244 matrix
- H HDMI Zone Output - connect directly to display or audio system
- I Cat 5e/6 cables connected to HMX-244 zone output. Either TIA/EIA 568A or 568B standards may be used – straight through, not crossover
- J Serial port (not used)

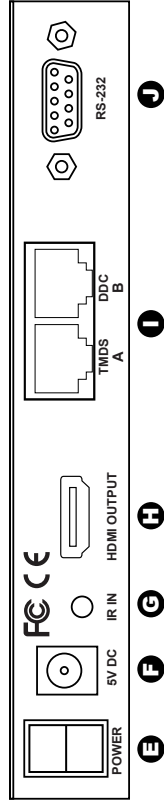
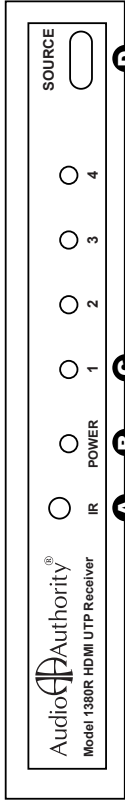

1380R IR REMOTE

- K IR remote control source 1 selection button

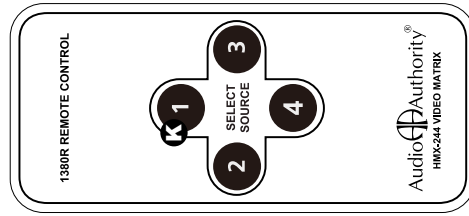

3.0 PLANNING A MATRIX SYSTEM

- Before installation, test the equipment for compatibility. Temporarily connect all of the sources, audio receivers, and displays to the matrix using short HDMI cables to verify basic compatibility and function. If any incompatibilities occur, connect the source and display or audio receiver without the matrix in the signal path for further HDMI troubleshooting.
- Since all of the displays connected to a particular source will be receiving the same video signal resolution and format (e.g. 1080p@60Hz) produced by the source, make sure the source is set up to output the highest resolution that **all of the displays can accept**. For instance, if one display can accept a maximum input resolution of 720p, all of the sources are limited to 720p output, and all displays will receive a maximum resolution of 720p. This consideration is particularly important if the TVs have a wide range of resolution capabilities because the highest resolution sets may not be allowed to perform to their best advantage.
- HDMI cable lengths should be kept as short as possible. Use the Cat 5 output for cable runs over 50 feet. High resolution settings, refresh rate, and/or deep color require increased bandwidth, and may effect the maximum cable run length that can be achieved.
- Connect a high quality HDMI cable from each HDMI source to an input of the matrix. Cable lengths should be kept as short as possible.
- To prevent HDMI connectors from becoming loose, add strain relief tie-downs a few inches away from every HDMI cable connector.
- Connect the outputs of the matrix to their destination devices using HDMI cables **OR** dual Cat 5 cables at each output – both types of output ports **may not** be used at once. Use 1380R Cat 5 zone receivers where cable lengths of 50 feet* or more are required. HDMI cables perform differently depending on quality of cable and the source equipment used.
- Connect the power adapter to an AC outlet and then to the matrix.
- If you are using the RS-232 control function, connect a standard serial cable from the controller to the HMX-244 RS-232 port.
- Turn on the HDMI sources and displays. Turn on the matrix and after a pause for HDCP handshaking, observe the source signals on the displays. The HMX-244 front panel LEDs light, indicating the active sources in each zone.

** Proper function of HDMI matrix routers and distribution systems depends on the use of high quality HDMI cables with low loss, high bandwidth signal handling capabilities. The distance specification cannot be guaranteed unless cables used throughout the system meet these high standards.*

4.0 CONNECTING THE HARDWARE

- Turn off equipment that will be connected to the matrix. Mount the matrix in an equipment rack if desired, using the included rack ears. Otherwise, place the matrix on a flat surface with adequate ventilation and access to the front and rear panels.

GETTING THE BEST RESULTS USING HDMI

Many factors influence the performance of an HDMI switching system. Consider the following precautions to ensure the best system performance.

- **Resolution tracking.** Refer to 3.0 “Planning a Matrix System” Set up the sources to output the best resolution that all TVs can accept.
- **Source resolution and video/sound quality.** Sources, such as satellite receivers or cable boxes may output at low resolutions or deliver extremely compressed video material, yielding poor results. Consider the sources when planning and troubleshooting your system.
- **Output display devices.** The quality of the output signal depends largely upon the type and quality of the HDMI display devices used.
- **Connection cables.** HDMI cable design and quality are extremely important in long cable runs where capacitance can severely degrade performance. Use premium cables; low quality cables are susceptible to interference. Always use good strain relief methods to prevent cables from becoming loose over time.
- **Distance between the sources and the displays.** Using premium quality cables the sources may be located up to 20m from the matrix, and the matrix may be up to 15m from each display device. Longer distances are possible using advanced HDMI extenders with DDC correction.
- **Interference.** Nearby electrical devices can negatively affect signal quality. For example, older computer monitors often emit strong electromagnetic fields that can interfere with the performance of adjacent video equipment.

VIDEO CONNECTIONS

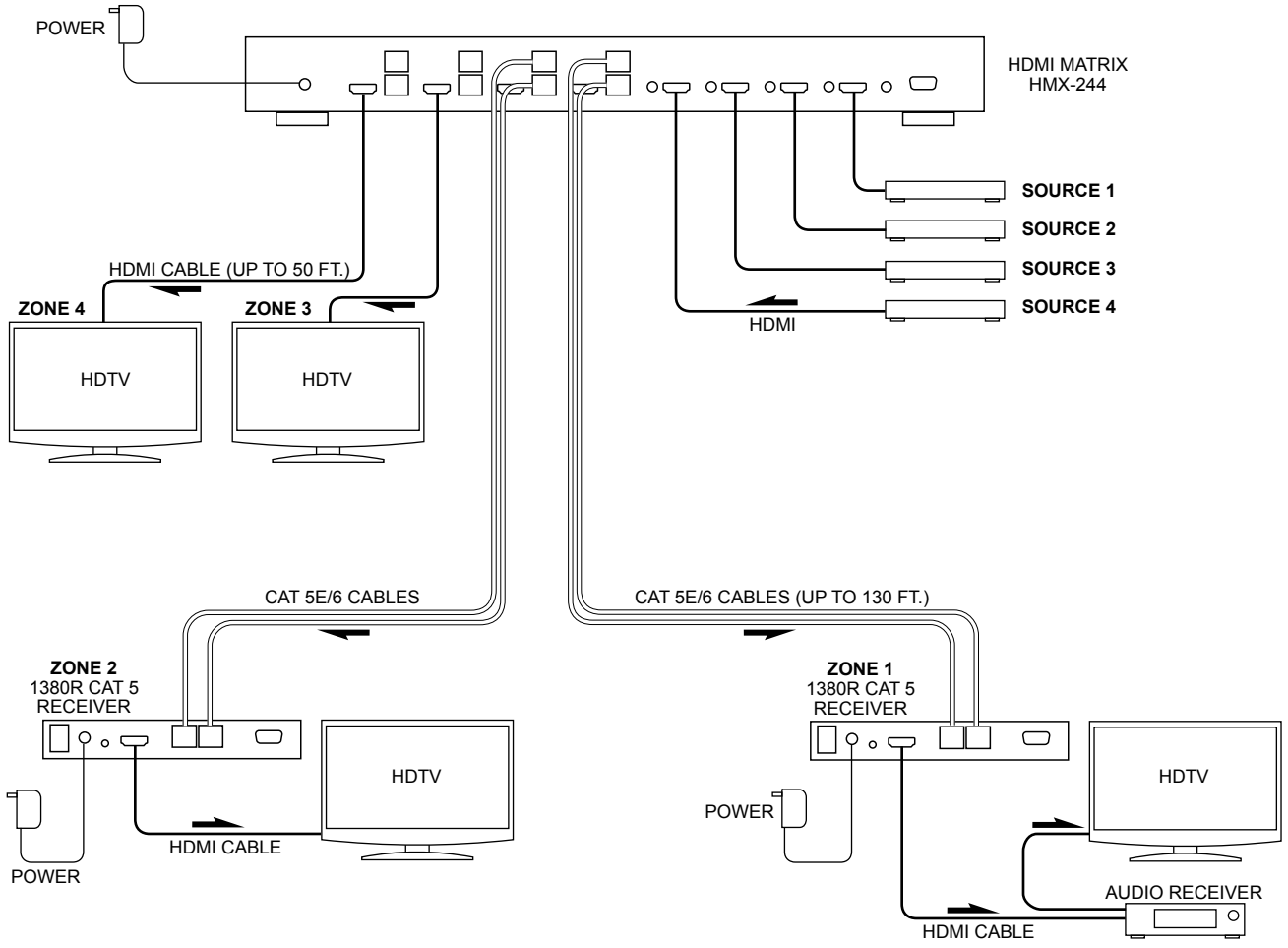

IR CONNECTIONS

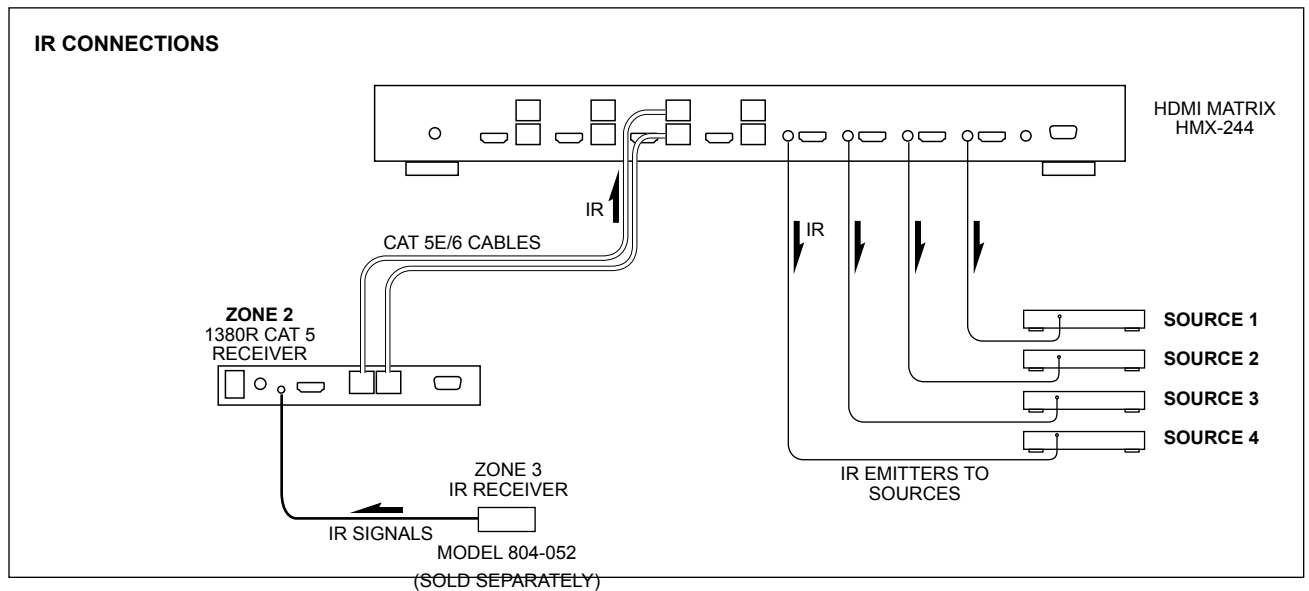

6.0 OPERATING THE MATRIX SWITCHER

The HMX-244 is a matrix switcher capable of routing audio/video signals from any of four sources to any of four displays. The matrix may be operated by the front panel controls, an IR remote control, or by RS-232 through a computer or other third party controller.

The HMX-244 begins to operate as soon as power is turned on, handshaking with sources and displays. Unused ports do not operate

6.1 FRONT PANEL CONTROLS

Repeatedly press the SOURCE button in the appropriate zone until the desired source (1, 2, 3, or 4) is selected.

- Lights (1-4) indicate the source that is currently selected to the zone output.
- If a source is not powered on, the HMX-244 skips to the next available source.
- The POWER light indicates that the unit is receiving power.

6.2 IR REMOTE CONTROLS

The HMX-244 includes a main remote control that can be used at the head end matrix location. It controls sources for all four zones. Each row of buttons represents a zone. To disconnect all sources to a zone, press OFF.

Auto Mode may be used to avoid any TV showing a blank screen. It automatically searches for a source input with active video signal beginning with input 1. If no signal is present, it searches input 2, 3, and 4. Override Auto Mode in any zone by pressing one of the other source buttons.

Each 1380R Cat 5 zone receiver includes a zone IR remote control. It controls only the zone output where the 1380R is located. If an external IR receiver is required, purchase a 5V demodulated IR receiver such as Model 804-052 from Audio Authority.

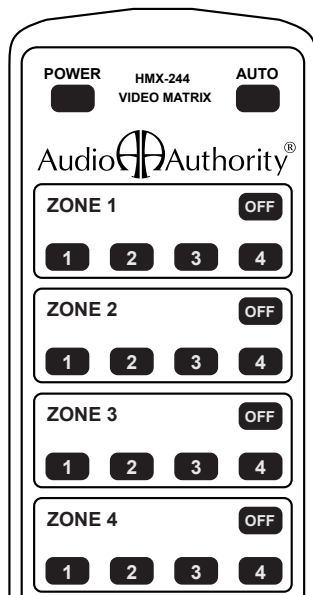

6.3 RS-232 SERIAL CONTROL

Connect a computer or other serial controller to the RS-232 port on the rear panel using an RS-232 cable. The HMX-244 serial commands are based on Windows™ OS super terminal. Commands include on, off, and source selection on any zone output.

Chose the right COM when setting “super terminal” and then set the parameters as follows:

Baud Rate: 4800 bps
Data bit: 8 Bits
Parity: None
Stop Bit: 1 bit
Data stream: None

- Each command should be two or three characters, followed by a carriage return. After each command, the HMX-244 responds with “successful operation”.
- The next command must be sent within three seconds or the error message: “Overtime instruction” appears.
- If an incorrect command is received, the error: “wrong instruction” appears.
- If the input or output is not connected or not in powered on, “ineffective instruction” appears.

SERIAL COMMANDS

These commands are for the HMX-244 only. The serial port on the Model 1380R receiver is not used.

The character for the zone output (A, B, C, or D) comes first, then the number for the source input:

- zone 3 to source 2 = C3(carriage return)
- zone 1 to source 4 = A4(carriage return), etc.

To turn the HMX-244 on or off enter the following:

- ON(carriage return)
- OFF(carriage return)

To query the status of the HMX-244 enter the following:

- QS(carriage return)

Important: all serial commands must be terminated with a carriage return and line feed.

7.0 TROUBLESHOOTING

- Make certain that the matrix is receiving power by looking at the power LED. It should be illuminated and not flickering. Intermittent operation generally means a problem with the DC power adapter or low AC voltage. Check the AC outlet for proper voltage, then consider replacing the DC power adapter.
 - If some lower resolution TVs do not display a picture, make sure the source is producing a resolution that all TVs can accept. Try 1080i, 720p and 480p. If possible, manually set the sources to the desired resolution. In some cases, hot-plugging a high resolution display may actually reset the source to a resolution that cannot be accepted by some other TVs.
 - If displays seem to “lose signal” momentarily, it could be normal HDMI switching behavior. All displays connected to a source must handshake again when that source is selected to a new display. This pause is normal and required when switching HDCP encrypted signals.
 - If some inputs function correctly and others do not, interchange cables between sources and see if the problem moves with the cables. If it moves, a bad cable or cable connector is the probable reason for the trouble.
- If the problem remains with one particular input, connect that source to a different input using the same cable and see if the problem moves to the new input. If it does, the problem is with the source. Connect the source directly to the lowest resolution display and adjust its output settings and resolution until satisfactory function is achieved.
- If 1080p resolution, deep color, and/or lossless audio is desired, very high bandwidth is required. HDMI cable design and quality are extremely important in long cable runs where capacitance can severely effect the bandwidth available. If a zone is not receiving HDMI signals, first make certain that the input cable is as short as possible and none of the output cables are more than 15 meters long. Try reducing the resolution, color depth and/or audio settings.
 - Remember that HDMI devices communicate with one another so the source device and all destination devices must be fully HDMI compliant. In addition, HDCP encryption requires processing dependent on the equipment you have connected to both the source and destination devices.

If a problem still persists after trying the above suggestions, contact the Audio Authority Technical Support department via email: support@audioauthority.com, or call 800-322-8346 or 859-233-4599.

8.0 SPECIFICATIONS

Signal Inputs/Output:	HDMI Connector	type A 19 pin female
	Input DDC Signal	5 volts p-p (TTL)
	Control Port	RS-232 female, mini-stereo
Operating Frequency:	Vertical Frequency Range	50/60Hz
	Video Amplifier Bandwidth	2.25Gbps/225MHz
Resolutions:	Interlaced (50&60Hz)	480i,576i,1080i
	Progressive (50&60Hz)	480p,576p,720p,1080p
Mechanical:	HMX-244 Cabinet Size (H-W-D)	1.75"x 17.2"x 6.9" (44x438x175mm)
	Weight (HMX-244 Matrix)	2218g net
Warranty:	Limited Warranty	1 year parts and labor
Environmental:	Operating Temperature	0° to +70°C
	Operating Humidity	10° to 85°C RH (no condensation)
	Storage Temperature	-10° to +80°C
	Storage Humidity	5% to 90% RH (no condensation)
Power Requirement:	Power Supply for HMX-244 Matrix	Output: 5.5V DC@4A; 20W
	Power Supply for 1380R Zone Receiver	Output: 5V DC@2A; 5W
Regulatory Approvals:	HMX-244 Matrix and 1380R Receiver	FCC, CE, UL
	Power Supply	FCC, CE, UL
Accessories Included:	AC Power Adapter	Input: AC 100-240V 50/60Hz, 1.5A
	Mounting Hardware	Rack ears for HMX-244
	User Manual	12 pages, printed

9.0 LIMITED WARRANTY

If any consumer product from Audio Authority fails due to defects in materials or workmanship within one year from the date of the original sale to the end-user, Audio Authority guarantees that we will replace the defective product at no cost. Freight charges for the replacement unit will be paid by Audio Authority (ground service only). A copy of the invoice showing the item number and date of purchase (proof-of-purchase) must be submitted with the defective unit to constitute a valid in-warranty claim.

Units that fail after the warranty period has expired may be returned to the factory for repair at a nominal charge, if not damaged beyond the point of repair. All freight charges for out-of-warranty returns for repair are the responsibility of the customer. Units returned for repair must have a Return Authorization Number assigned by the factory.

This is a limited warranty and is not applicable for products which, in our opinion, have been damaged, altered, abused, misused, or improperly installed. Audio Authority makes no other warranties either expressed or implied, including limitation warranties as to merchantability or fitness for a particular purpose. Additionally, there are no allowances or credits available for service work or installation performed in the field by the end user.

9.1 WARRANTY SERVICE PROCEDURES

If you suspect a product defect, contact Audio Authority's Technical Service Department at 800-322-8346 or 859-233-4599 for assistance in verifying the problem. If a defect or potential defect is suspected, a replacement unit will be shipped immediately on a defect-exchange basis and a Return Authorization Number will be issued for the return of the defective product. Replacement units are sent out at the Manufacturer's Suggested Retail Price which is debited to the Customer's Credit Card at the time of shipment. Once we receive the defective unit back at the factory, it will be evaluated under the conditions of this warranty and if found to be in-warranty, a full credit will be issued to the Customer's Credit Card. Return freight charges for the defective unit are the customer's responsibility. Please contact our Technical Support Department for complete details concerning all in and out of warranty service matters.

We appreciate your confidence in our products and services and will always strive to meet or exceed your needs.

10.0 REGULATORY COMPLIANCE

The HMX-244 and 1380R have been tested for compliance with CE and FCC rules and regulations. Power supplies included have been tested for compliance with UL, CUL, CE, PSE, and GS regulations and guidelines. This product and its power supply are RoHS compliant.

11.0 CONTACT INFORMATION

If you have questions or require assistance with this product in areas not covered by this manual, please contact Audio Authority using the information below.

Audio Authority Technical Support
800-322-8346 M-F 8:30 AM to 5:00 PM, EST
International: 859-233-4599 Fax: 859-233-4510
Send email to: support@audioauthority.com

Audio Authority Corporation
2048 Mercer Road
Lexington, Kentucky 40511-1071
USA



2048 Mercer Road, Lexington, Kentucky 40511-1071

Phone: 859/233-4599 • Fax: 859/233-4510

Customer Toll-Free USA & Canada: 800/322-8346

Website: <http://www.audioauthority.com>