

Installing the Model 1523 Customer Video Add-on

The Model 1523 Video Add-on may be used in any 1500 Series Intercom installation where video is desired. It can be mounted on either side, back or bottom. A Model 1523 plugs into a 1520 Lane Station providing two-way video and camera tilt control.

Installation

1. Decide which surface will be used to mount the Model 1523. Using the included template, carefully remove the knockouts with a hammer and screwdriver; dress the holes with a utility knife if necessary.
2. Run the Cat 5 video cable from inside the Model 1523 and the heater power supply cable through the hole made in Step 1.
3. Connect the video Cat 5 cable to the video jack on the 1520 Lane Station. Connect the heater power supply cable to the heater power jack near the fan.
4. Connect the heater power supply into a source of 100-260 volts AC.
5. Secure the Model 1523 to the mounting surface using the screws provided.

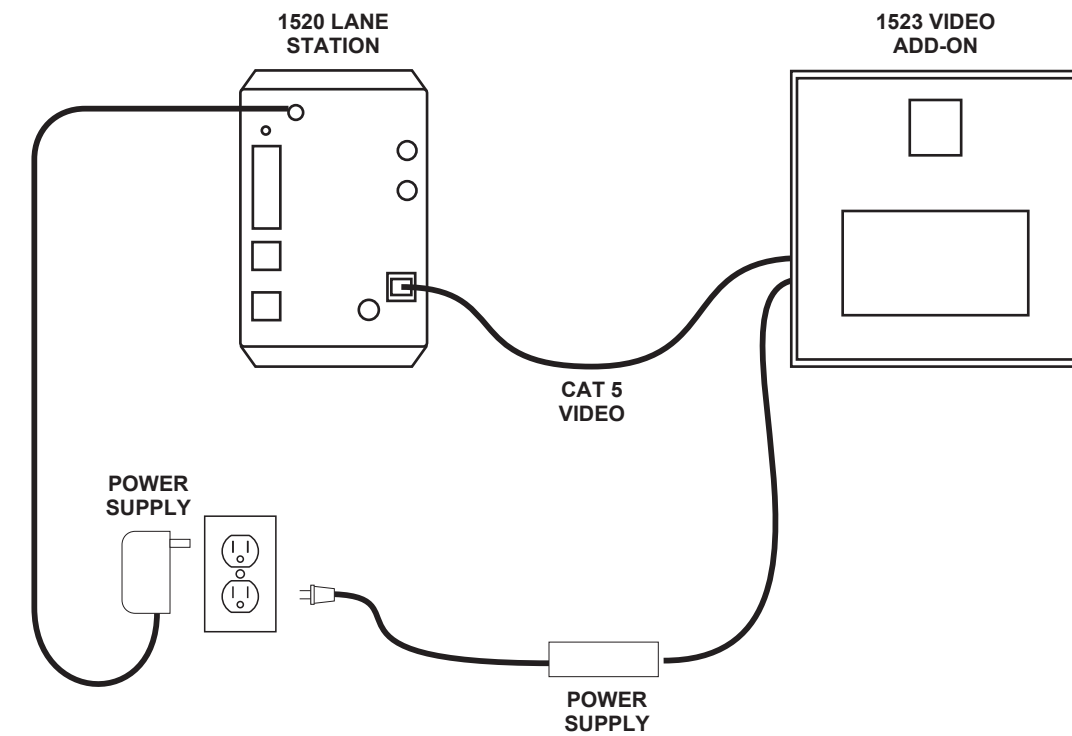

Troubleshooting

If any problem should arise that is not discussed in these instructions, call the Audio Authority Technical Service Department at 800-322-8346, 8:30 AM to 5:00 PM, M - F, EST.

